

**TIANMA Microelectronics (U.S.A.) Inc.**

**SPECIFICATION FOR LCD MODULE**

Model No. TM12864GDAW

**To:**

Customer's Approval

Date: \_\_\_\_\_

By: \_\_\_\_\_

Presented

By: \_\_\_\_\_

Tianma Microelectronics (U.S.A.) Inc.

**REVISION RECORD**

<b>Date</b>	<b>Ref. Page</b>	<b>Revision No.</b>	<b>Revision Items</b>	<b>Check &amp; Approval</b>

## **1 Display Specifications**

**1.1 Display type: STN**

**1.2 Display color\*:**

Display color: Blue-Black

Background: Gray

**1.3 Polarizer mode: Reflective / Positive.**

**1.4 Viewing Angle: 6:00**

**1.5 Driving Duty: 1/64**

**1.6 Backlight: No Back Light**

**\* Color tone is slightly changed by temperature and driving voltage.**

## **2 Mechanical Specifications**

**2.1 Outline Dimensions: Refer to outline drawing on page: 2**

**2.2 Dot Matrix: 128X64**

**2.3 Dot Size: 0.48X0.48(mm)**

**2.4 Dot Pitch: 0.51X0.51 (mm)**

**2.5 Weight:**

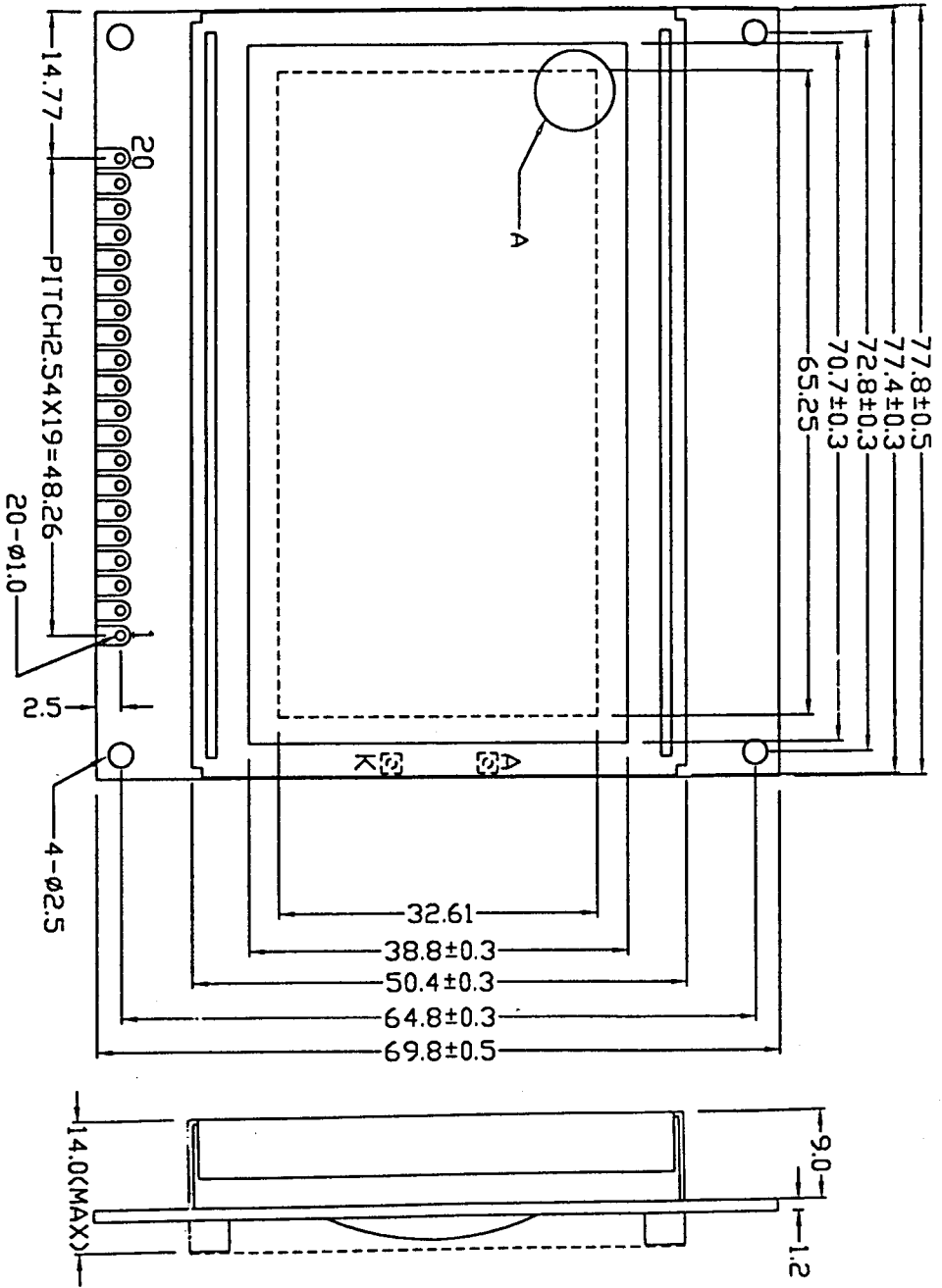

1	2	3	4	5	6	7	8	9	10	11	12	13	14	15	16	17	18	19	20
VSS	VDD	V0	D/I	R/W	E	DB0	DB1	DB2	DB3	DB4	DB5	DB6	DB7	CS1	CS2	RST	Vout	A	K

### 3 Circuit Block Diagram

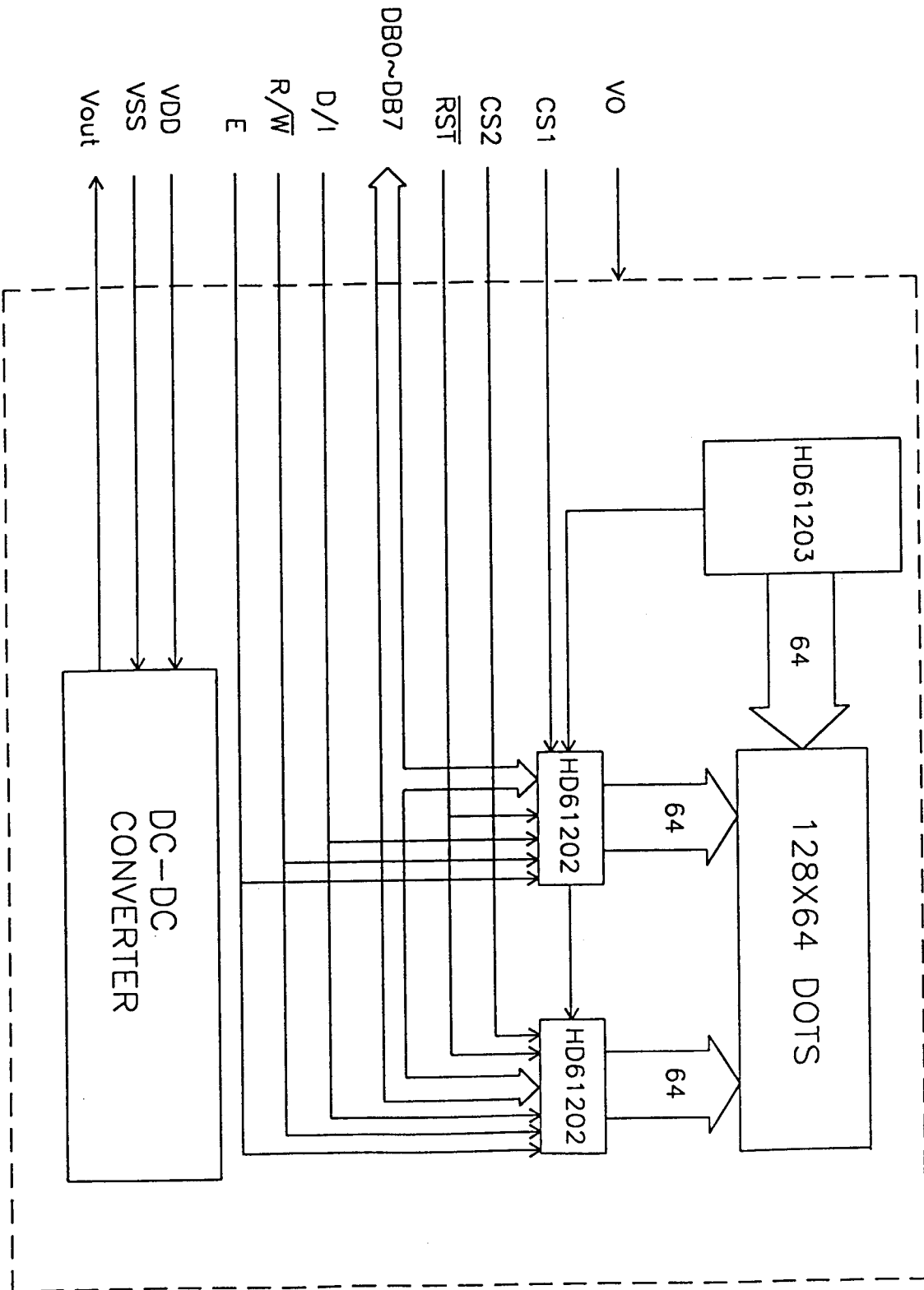

#### 4 Absolute Maximum Ratings

Item	Symbol	Min.	Max.	Unit	Remark
Power Supply Voltage	$V_{DD}-V_{SS}$	-0.3	6.0	V	
LCD Driving Voltage	$V_{DD}-V_{EE}$	\	25.0		
Operating Temperature Range	$T_{OP}$	-20	+70	°C	No Condensation
Storage Temperature Range	$T_{ST}$	-30	+80		

#### 5 Electrical Specifications and Instruction Code

##### 5.1 Electrical characteristics

Item		Symbol	Min.	Typ.	Max.	Unit	Remark
Supply Voltage (Logic)		$V_{DD}-V_{SS}$	4.75	5.0	5.25	V	
Supply Voltage (LCD Drive)		$V_{DD}-V_{EE}$	-	11.0	-	V	
Input Signal Voltage	'H'Level	$V_{IH}$	$0.8V_{DD}$	-	$V_{DD}+0.3$	V	
	'L'Level	$V_{IL}$	0	-	$0.2 V_{DD}$	V	
Supply current (Logic)		$I_{DD}$	-	2.5	-	mA	
Supply current (LCD Drive)		$I_{EE}$	-	2.5	-	mA	

<b>Pin No.</b>	<b>Symbol</b>	<b>Level</b>	<b>Description</b>
1	V <sub>ss</sub>	0V	Ground
2	V <sub>dd</sub>	5.0V	Power supply voltage for logic (+5V)
3	V <sub>o</sub>	11.0V	Voltage Level for LCD Contrast Adjust
4	D/I	H/L	Data/Instruction
5	R/W	H/L	Selects read or write
6	E	H/L	Enable Input
7	DB0	H/L	Data bit0
8	DB1	H/L	Data bit1
9	DB2	H/L	Data bit2
10	DB3	H/L	Data bit3
11	DB4	H/L	Data bit4
12	DB5	H/L	Data bit5
13	DB6	H/L	Data bit6
14	DB7	H/L	Data bit7
15	CS1	H/L	Chip Select Signal 1
16	CS2	H/L	Chip Select Signal 2
17	/RST	H/L	Reset Signal
18	V <sub>out</sub>	-6.0V	Voltage of DC-DC Output
19	A		
20	K		

# 5.3 Interface Timing Chart:

MPU Interface						
Characteristic	Symbol	Min	Typ	Max	Unit	
E Cycle	$t_c$	1000	-	-	ns	
E High Level Width	$t_{wh}$	450	-	-	ns	
E Low Level Width	$t_{wl}$	450	-	-	ns	
E Rise Time	$t_r$	-	-	25	ns	
E Fall Time	$t_f$	-	-	25	ns	
Address Set-Up Time	$t_{ASU}$	140	-	-	ns	
Address Hold Time	$t_{AH}$	10	-	-	ns	
Data Set-Up Time	$t_{DSU}$	200	-	-	ns	
Data Delay Time	$t_D$	-	-	320	ns	
Data Hold Time (Write)	$t_{DHW}$	10	-	-	ns	
Data Hold Time (Read)	$t_{DHE}$	20	-	-	ns	

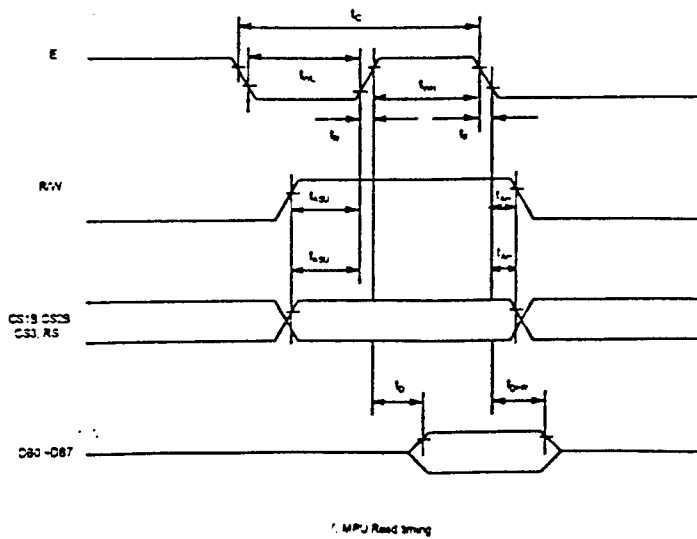
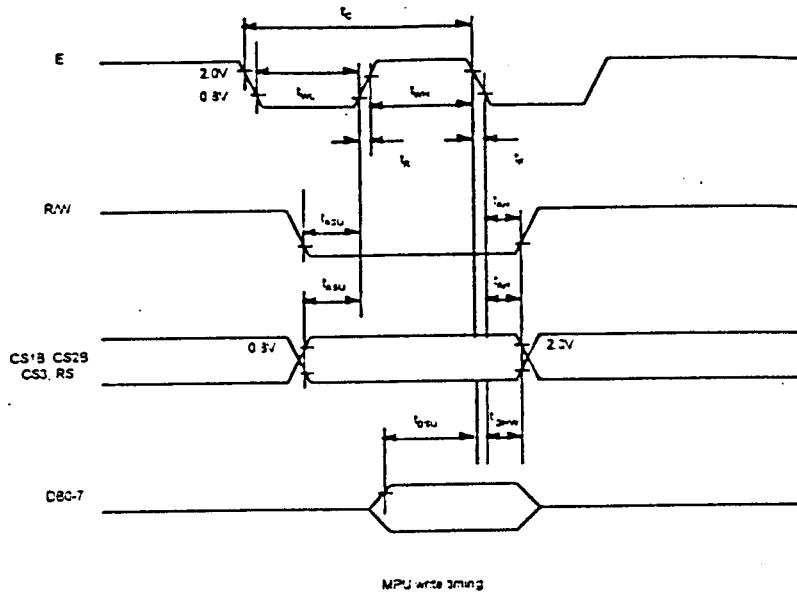



## 5.4 Instruction Code

### DISPLAY CONTROL INSTRUCTION

The display control instructions control the internal state of the KS0108B. Instruction is received from MPU to KS0108B for the display control. The following table shows various instructions.

Instruction	RS	R/W	DB7	DB6	DB5	DB4	DB3	DB2	DB1	DB0	Function	
Display ON/OFF	L	L	L	L	H	H	H	H	H	L/H	Controls the display on or off. Internal status and display RAM data is not affected. L:OFF, H:ON	
Set Address (Y address)	L	L	L	H	Y address (0-63)						Sets the Y address in the Y address counter.	
Set Page (X address)	L	L	H	L	H	H	H	Page (0-7)			Sets the X address at the X address register.	
Display Start Line (Z address)	L	L	H	H	Display start line (0-63)						Indicates the display data RAM displayed at the top of the screen.	
Status Read	L	H	B U S Y	L	O N / O F F	R E S E T	L	L	L	L	Read status. BUSY L: Ready H: In operation ON/OFF L: Display ON H: Display OFF RESET L: Normal H: Reset	
Write Display Data	H	L	Write Data									Writes data (DB0:7) into display data RAM. After writing instruction, Y address is increased by 1 automatically.
Read Display Data	H	H	Read Data									Reads data (DB0:7) from display data RAM to the data bus.

## 6. Optical Characteristics

### 6.1 Optical Characteristics

Top=25°C

Item		Symbol	Condition	Min.	Typ.	Max.	Unit	Remark
Viewing Angle		$\theta_x$	$Cr \geq 2$	$\theta_y = 0^\circ$		-30 -- 20	Deg	
		$\theta_y$		$\theta_x = 0^\circ$		-30 -- 30		
Contrast Ratio		Cr	$\theta_x = 0^\circ$ $\theta_y = 0^\circ$	3.0				
Response Time	Turn on	$T_{on}$	$\theta_x = 0^\circ$ $\theta_y = 0^\circ$			300	ms	
	Turn off	$T_{off}$				300		

## 6.2 Definition of optical characteristics

### 6.2.1 Definition of viewing Angle(see fig. as follow)

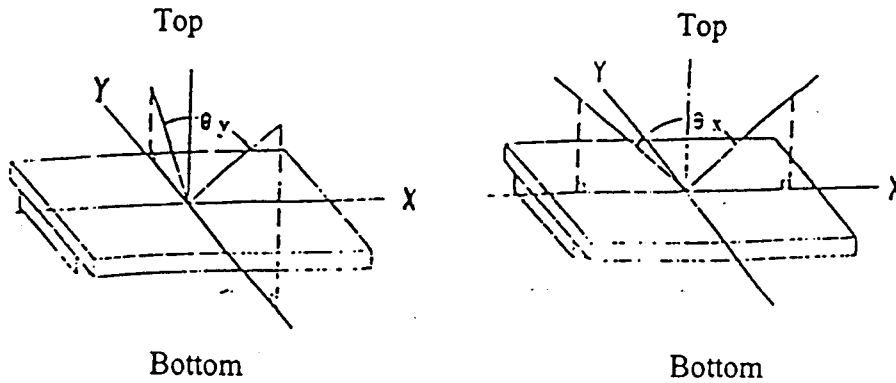

### 6.2.2 Definition of Contrast Ratio(see fig. as follow)

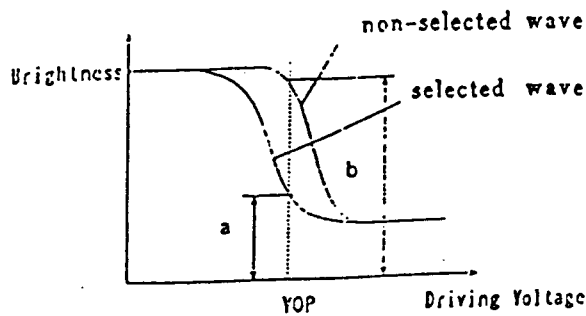

$$\text{Contrast Ratio} = b / a = \frac{\text{non-selected state brightness}}{\text{selected state brightness}}$$

Measuring Conditions:

- 1) Ambient Temperature: 25°C ;
- 2) Frame frequency: 64Hz

### 6.2.3 Definition of Response time(see fig. as follow)

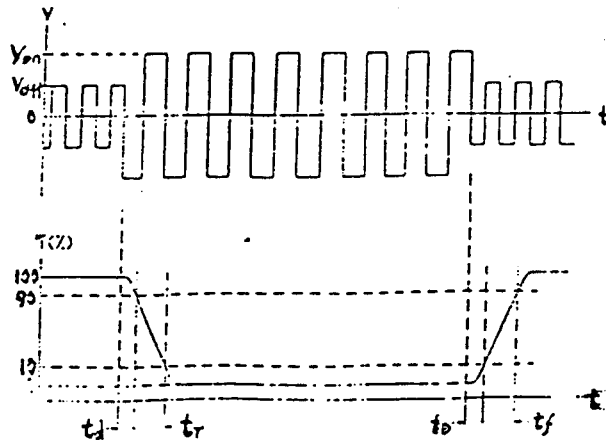

$$\text{Turn-on time: } t_{on} = t_d + t_r$$

$$\text{Turn-off time: } t_{off} = t_d + t_f$$

Measuring Condition:

- 1) Operating Voltage: 11.0V;
- 2) Frame frequency: 64Hz

## 7. Reliability

### 7.1 Content of Reliability Test

( $T_{OP}=25^{\circ}C$ )

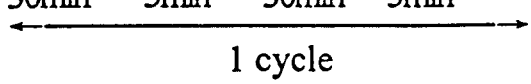
No.	Test Item	Content of Test	Test condition
1	High Temperature Storage	Endurance test applying the high storage temperature for a long time	80°C 500H
2	Low Temperature Storage	Endurance test applying the low storage temperature for a long time	-30°C 500H
3	High Temperature Operation	Endurance test applying the electric stress (voltage & current) and the thermal stress to the element for a long time	70°C 500H
4	Low Temperature Operation	Endurance test applying the electric stress under low temperature for a long time	-20°C 500H
5	High Temperature /Humidity Storage	Endurance test applying the high temperature and high humidity storage for a long time	60°C 95%RH 360H
6	Temperature Cycle	Endurance test applying the low and high temperature cycle $-20^{\circ}C \longleftrightarrow 25^{\circ}C \longleftrightarrow 60^{\circ}C \longleftrightarrow 25^{\circ}C$ 30min    5min    30min    5min 	-30°C/80°C 10 cycles
7	Vibration Test (package state)	Endurance test applying the vibration during transportation	10Hz~500Hz, 100m/s <sup>2</sup> , 120min
8	Shock Test (package state)	Endurance test applying the shock during transportation	Half-sinewave, 100m/s <sup>2</sup> , 11ms
9	Atmospheric Pressure Test	Endurance test applying the atmospheric pressure during transportation by air	25kPa 16H

## 7.2 Failure Judgment Criterion

Criterion Item	Test Item No.									Failure Judgement Criterion
	1	2	3	4	5	6	7	8	9	
Basic Specification	0	0	0	0	0	0	0	0	0	Out of the basic Specification
Electrical specification	0	0	0	0	0					Out of the electrical specification
Mechanical Specification							0	0		Out of the mechanical specification
Optical Characteristic	0	0	0	0	0	0			0	Out of the optical specification
Remark	Basic specification = Optical specification + Mechanical specification									

## 8 Precautions for use of LCD Modules

### 8.1 Handling Precautions

- 8.1.1 The display panel is made of glass. Do not subject it to a mechanical shock by dropping it from a high place, etc.
- 8.1.2 If the display panel is damaged and the liquid crystal substance inside it leaks out, be sure not to get any in your mouth, if the substance comes into contact with your skin or clothes, promptly wash it off using soap and water.
- 8.1.3 Do not apply excessive force to the display surface or the adjoining areas since this may cause the color tone to vary.
- 8.1.4 The polarizer covering the display surface of the LCD module is soft and easily scratched. Handle this polarizer carefully.
- 8.1.5 If the display surface is contaminated, breathe on the surface and gently wipe it with a soft dry cloth. If still not completely clear, moisten cloth with one of the following solvents:
- Isopropyl alcohol
  - Ethyl alcohol
- Solvents other than those mentioned above may damage the polarizer. Especially, do not use the following:
- Water
  - Ketone
  - Aromatic solvents
- 8.1.6 Do not attempt to disassemble the LCD Module.
- 8.1.7 If the logic circuit power is off, do not apply the input signals.
- 8.1.8 To prevent destruction of the elements by static electricity, be careful to maintain an optimum work environment.
- a. Be sure to ground the body when handling the LCD Modules.
  - b. Tools required for assembly, such as soldering irons, must be properly ground.
  - c. To reduce the amount of static electricity generated, do not conduct assembly and other work under dry conditions.
  - d. The LCD Module is coated with a film to protect the display surface. Be care when peeling off this protective film since static electricity may be generated.

## 8.2 Storage precautions

8.2.1 When storing the LCD modules, avoid exposure to direct sunlight or to the light of fluorescent lamps.

8.2.2 The LCD modules should be stored under the storage temperature range. If the LCD modules will be stored for a long time, the recommend condition is:

temperature :  $0^{\circ}\text{C} \sim 40^{\circ}\text{C}$

relatively humidity:  $\leq 80\%$

8.2.3 The LCD modules should be stored in the room without acid, alkali and harmful gas.

8.3 The LCD modules should be no falling and violent shocking during transportation, and also should avoid excessive press, water, damp and sunshine.