



PARA LIGHT ELECTRONICS CO., LTD.
4F, No.1, Lane 93, Chien Yi Road, Chung Ho City, Taipei, Taiwan
Tel: 886-2-2225-3733 Fax: 886-2-2225-4800
E-mail: para@para.com.tw <http://www.para.com.tw>

DATA SHEET

PART NO.: L-T670LGCT

REV: A / 5

CUSTOMER'S APPROVAL : _____ DCC : _____

DRAWING NO. : DS-7A-07-0005

DATE : 2009-10-31

PAGE 1 of 15



SURFACE MOUNT DEVICE LED

Part No. : L-T670LGCT

REV: A / 5

● Features

- * Top view, Wide view angle, pure green color PLCC 2 package SMD LED .
- * EIA STD package, packing in 8mm tape on 7" diameter reels (ANSI/EIA-481-B-2001).
- * Compatible with automatic Pick & Place equipment.
- * Compatible with IR Reflow soldering and TTW soldering.
- * Pb free product and acceptable lead-free process.
- * Meet RoHS Green Product.

● Application

- * Backlighting (Switches, keys, displays, illuminated advertising)
- * Emergency lighting / Signal and symbol luminaries.

● Package Outline Dimensions

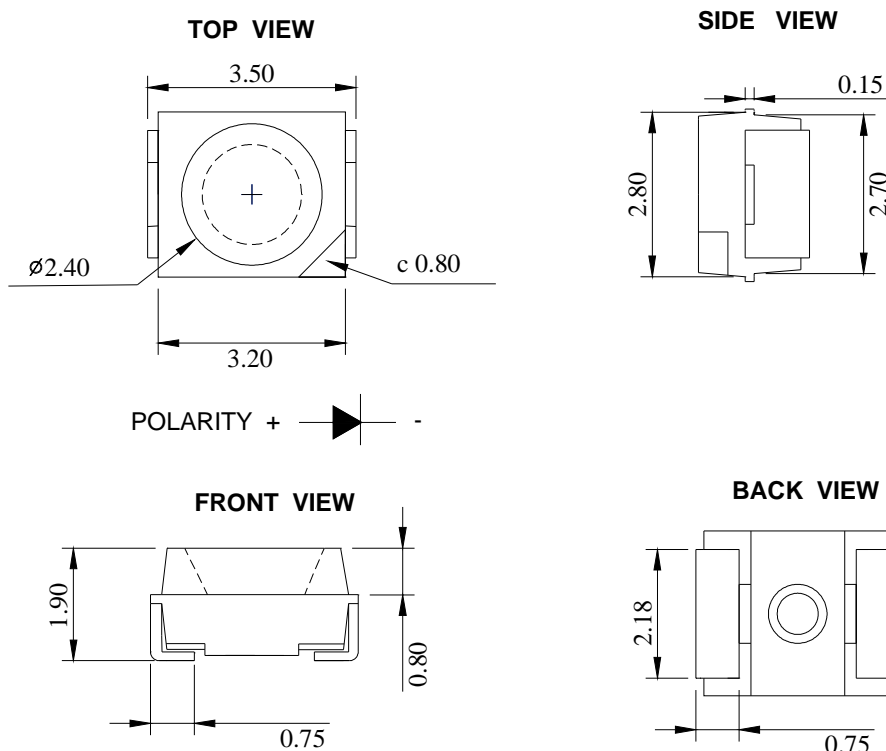

Notes:

1. All dimensions are in millimeters.
2. Tolerance is $\pm 0.10\text{mm}$ (.004") unless otherwise noted.



SURFACE MOUNT DEVICE LED

Part No. : L-T670LGCT

REV: A / 5

● CHIP MATERIALS

- * Dice Material : InGaN
- * Light Color : Pure Green
- * Lens Color : Water Clear

● Absolute Maximum Ratings(Ta=25°C)

Symbol	Parameter	Rating	Unit
P _D	Power Dissipation	75	mW
I _{PF}	Peak Forward Current (1/10 Duty Cycle, 0.1ms Pulse Width)	100	mA
I _F	Continuous Forward Current	20	mA
V _R	Reverse Voltage	5	V
ESD	Electrostatic Discharge Threshold(HBM) ^{Note A}	1000	V
Topr	Operating Temperature Range	-40 ~ + 85	°C
Tstg	Storage Temperature Range	-40 ~ + 85	°C
T _{sld}	Soldering Temperature (One times MAX.)	Reflow Soldering:260°C (for 10seconds)	
		Hand Soldering:350°C (for 3 seconds)	

Note A :

HBM : Human Body Model. Seller gives no other assurances regarding the ability of to withstand ESD.

● Electro-Optical Characteristics (Ta=25°C)

Parameter	Symbol	Min.	Typ.	Max.	Unit	Test Condition
Luminous Intensity	I _V	650	1000		mcd	I _F =20mA
Viewing Angle	$2 \theta_{1/2}$		120		Deg	
Peak Emission Wavelength	λ_p		520		nm	Measurement @Peak
Dominant Wavelength	λ_D		525		nm	I _F =20mA
Forward Voltage	V _F		3.0	3.50	V	I _F = 20mA
Spectrum Radiation Bandwidth	$\Delta\lambda$		25		nm	I _F =20mA
Reverse Current	I _R			10	μ A	V _R = 5V



SURFACE MOUNT DEVICE LED

Part No. : L-T670LGCT

REV: A / 5

Notes:

1. Luminous intensity is measured with a light sensor and filter combination that proximates the CIE eye-response curve.
2. $\theta_{1/2}$ is the off-axis angle at which the luminous intensity is half the axial luminous intensity.
3. Caution in ESD :
Static Electricity and surge damages the LED. It is recommended use a wrist band or anti-electrostatic glove when handling the LED. All devices, equipment and machinery must be properly grounded.
4. Major standard testing equipment by "Instrument System" Model : CAS140B Compact Array Spectrometer and "KEITHLEY" Source Meter Model : 2400.

● Typical Electro-Optical Characteristics Curves

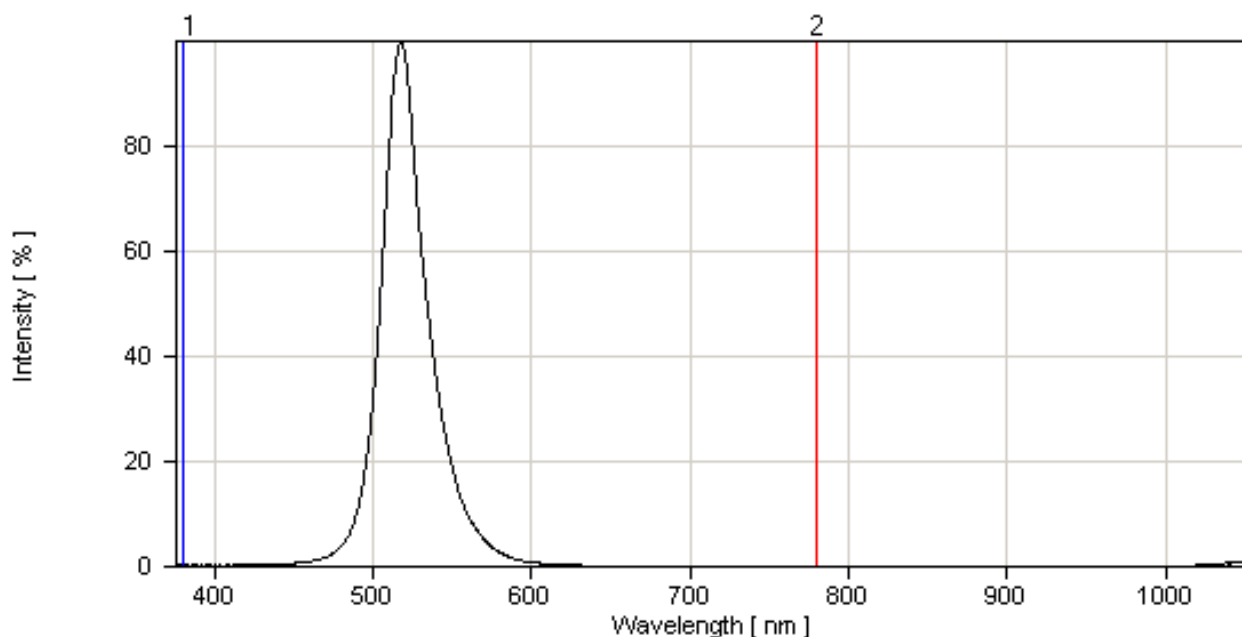

Fig.1 Relative Intensity vs. Wavelength



SURFACE MOUNT DEVICE LED

Part No. : L-T670LGCT

REV: A / 5

● Typical Electro-Optical Characteristics Curves

(25°C Ambient Temperature Unless Otherwise Noted)

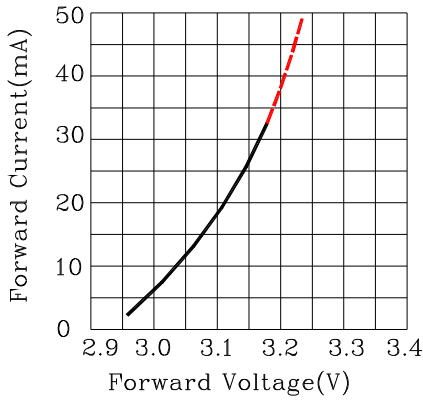

Fig.1 Forward Current vs. Forward Voltage

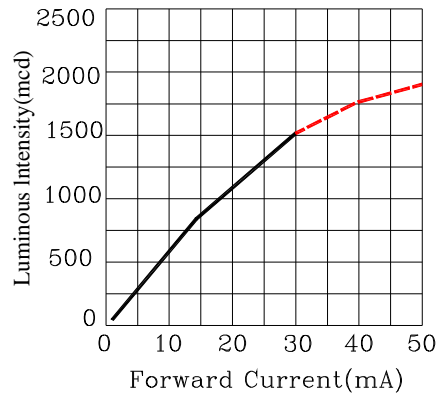

Fig.2 Luminous Intensity vs. Forward Current

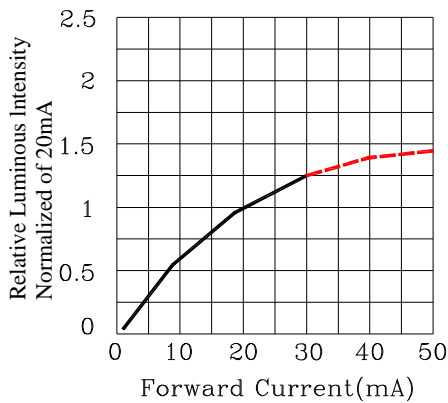

Fig.3 Relative Luminous Intensity vs. Forward Current

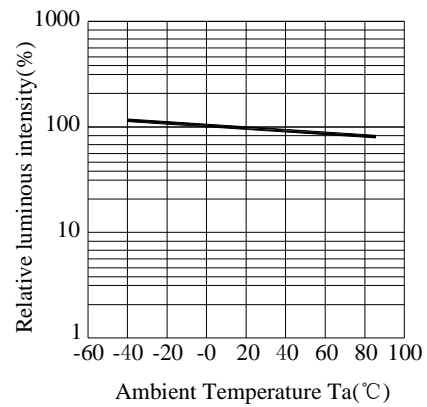

Fig.4 Luminous Intensity vs. Ambient Temperature

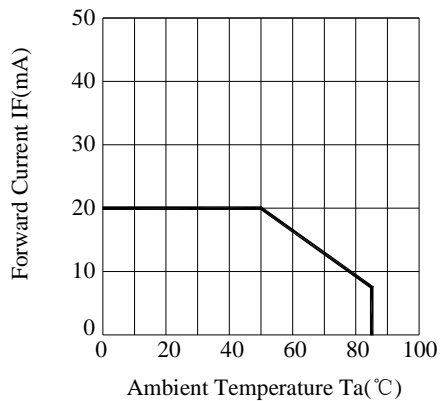

Fig.5 Forward Current Derating Curve

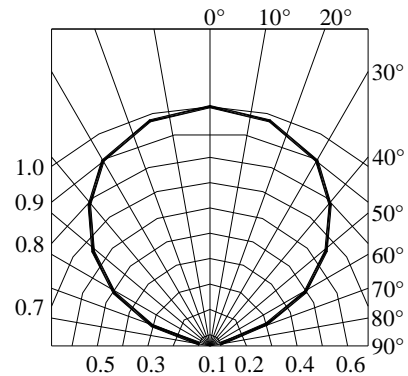

Fig.6 Relative Intensity vs. Angle



SURFACE MOUNT DEVICE LED

Part No. : L-T670LGCT

REV: A / 5

● **Bin Code List**

Luminous Intensity(IV), Unit:mcd@20mA		
Bin Code	Min	Max
P20	650	800
P21	800	1000
P22	1000	1250
P23	1250	1550

Forward Voltage(VF), Unit:V@20mA		
Bin Code	Min	Max
14	2.9	3.0
15	3.0	3.1
16	3.1	3.2
17	3.2	3.3
18	3.3	3.4
19	3.4	3.5

Tolerance of each bin are $\pm 10\%$

Tolerance of each bin are ± 0.1 Volt

Dominant Wavelength (Hue),Unit: nm@20mA		
Bin Code	Min	Max
AP	520	525
AQ	525	530

Tolerance of each bin are ± 1 nm



SURFACE MOUNT DEVICE LED

Part No. : L-T670LGCT

REV: A / 5

● Label Explanation



CUS. PART NO: To be denominated.

CUSTOMER: To be denominated.

PART NO: Refer to P15

P22--- Luminous Intensity Code

15--- Forward Voltage Code

AQ--- Dominant Wavelength

LOT NO: E L S 7 8 0001
 A B C D E F

A---E: For series number

B---L: Local F: Foreign

C---S: PLCC SMD

D---Year

E---Month

F---SPEC.

PACKING QUANTITY OF BAG :

2000pcs for T670 series

2000pcs for T650 series

2000pcs for S020 series

DATE CODE: 2007 08 29
 G H I

G--- Year

H--- Month

I --- Day



SURFACE MOUNT DEVICE LED

Part No. : L-T670LGCT

REV: A / 5

● Reel Dimensions

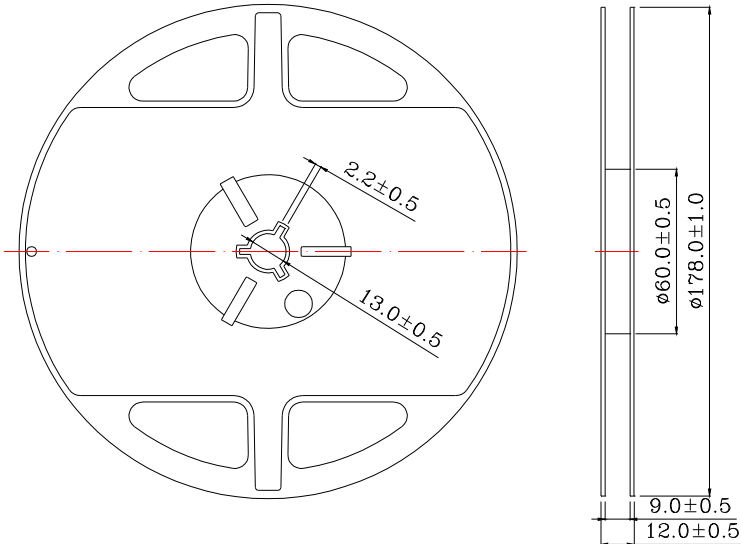

Notes:

1. Taping Quantity : 2000pcs
2. The tolerances unless noted is $\pm 0.1\text{mm}$, Angle $\pm 0.5^\circ$, Unit: mm.

● Suggest Soldering Pad Dimensions

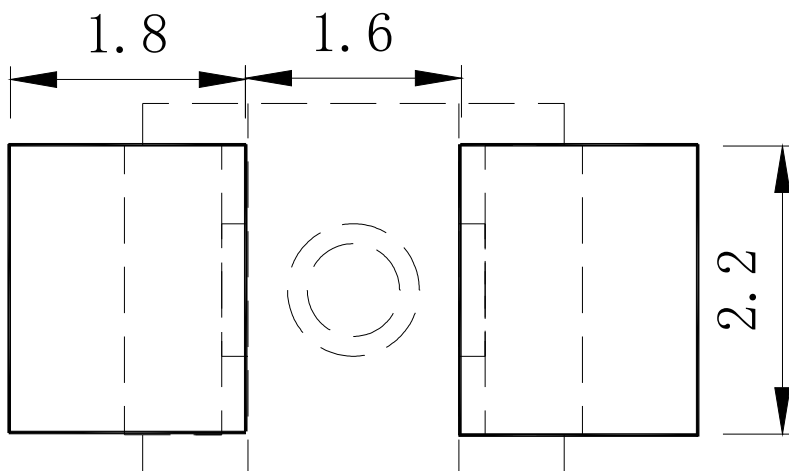

● Package Dimensions Of Tape And Reel

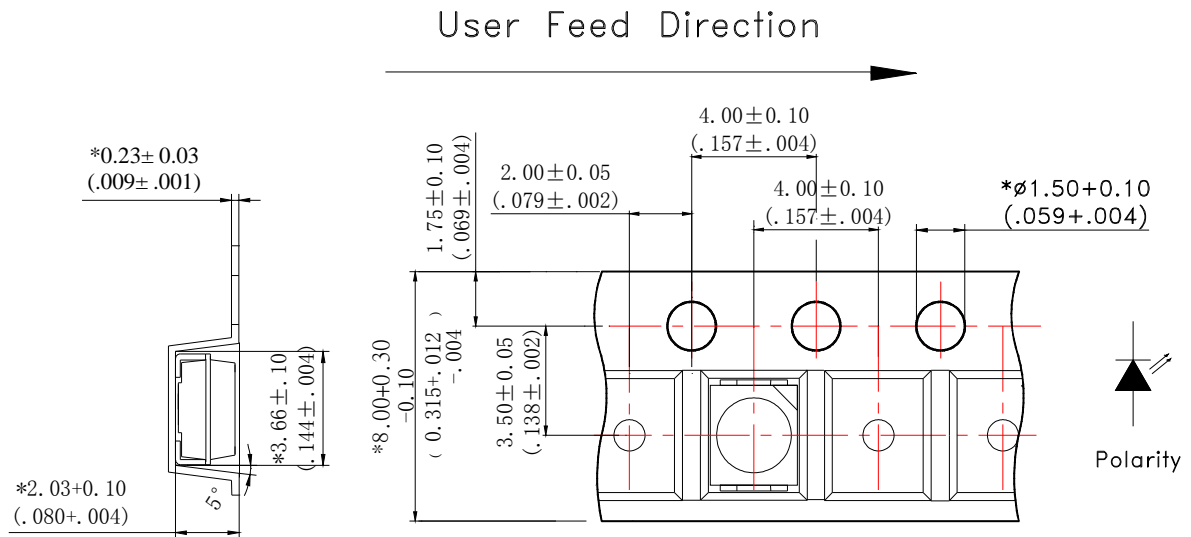

Notes: All dimensions are in millimeters.

● Packaging Of Electronic Components On Continuous Tapes

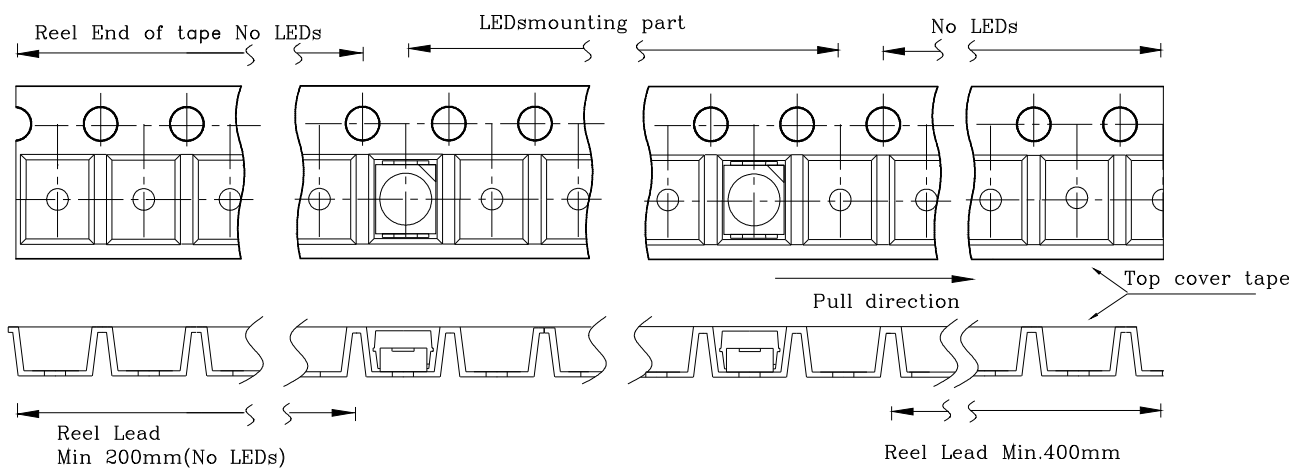

● **Moisture Resistant Packaging**

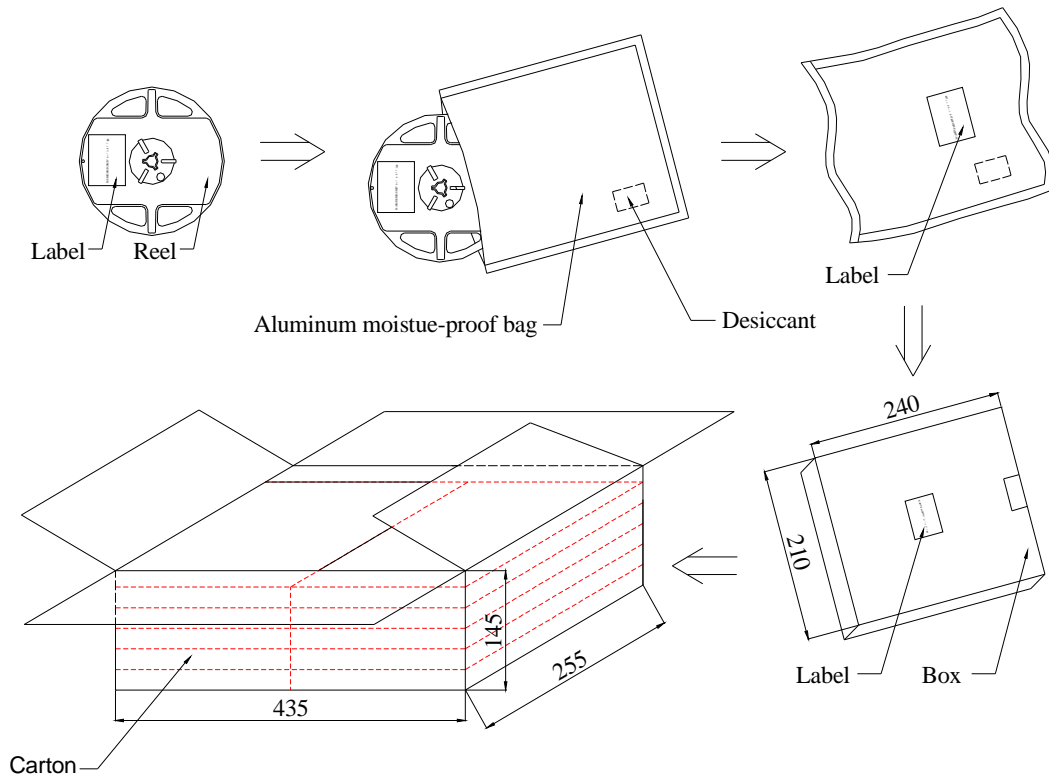

Notes : One reel in a bag, one bag in a inner box, ten inner boxes in a carton. Unit : mm.

● **Cleaning**

- * If cleaning is required , use the following solutions for less than 1 minute and less than 40°C .
- * Appropriate chemicals: isopropyl alcohol. (When using other solvents, it should be confirmed beforehand whether the solvents will dissolve the package and the resin or not.)
- * Effect of ultrasonic cleaning on the LED resin body differs depending on such factors as ultrasonic power and the assembled condition. Before cleaning, a pre-test should be confirm whether any damage to the LEDS will occur.



SURFACE MOUNT DEVICE LED

Part No. : L-T670LGCT

REV: A / 5

● Suggest Sn/Pb IR Reflow Soldering Profile Condition:

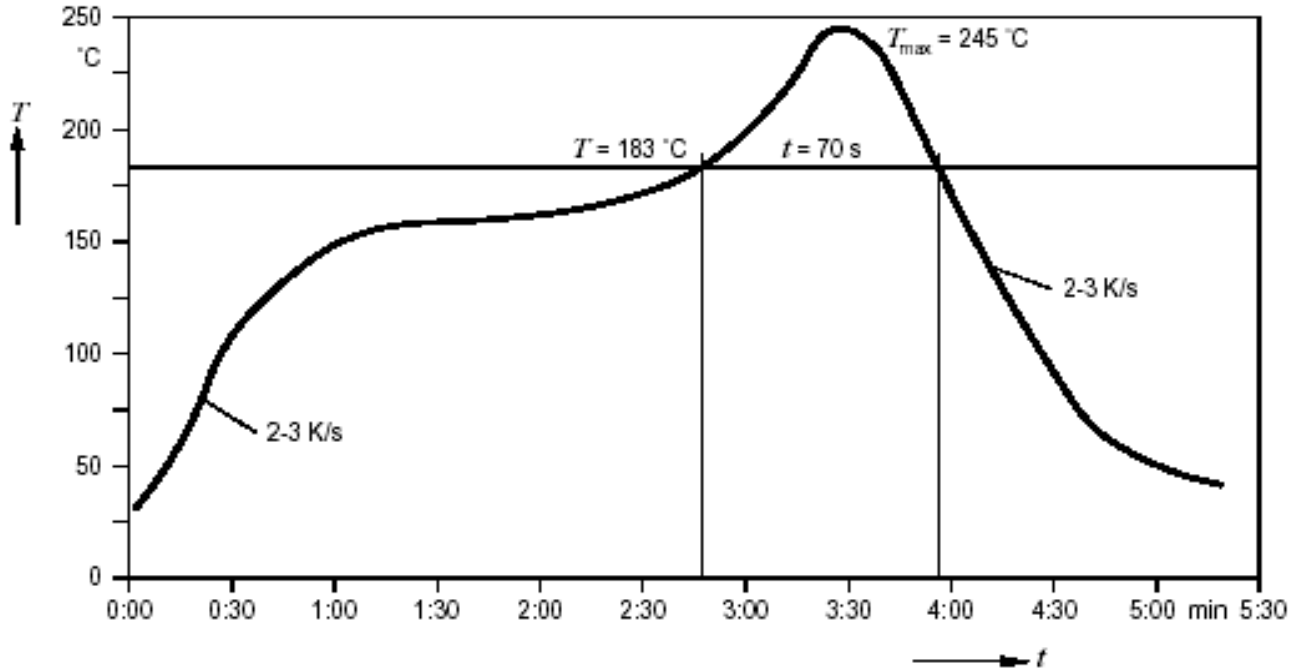

● Suggest Pb-Free IR Reflow Soldering Profile Condition:

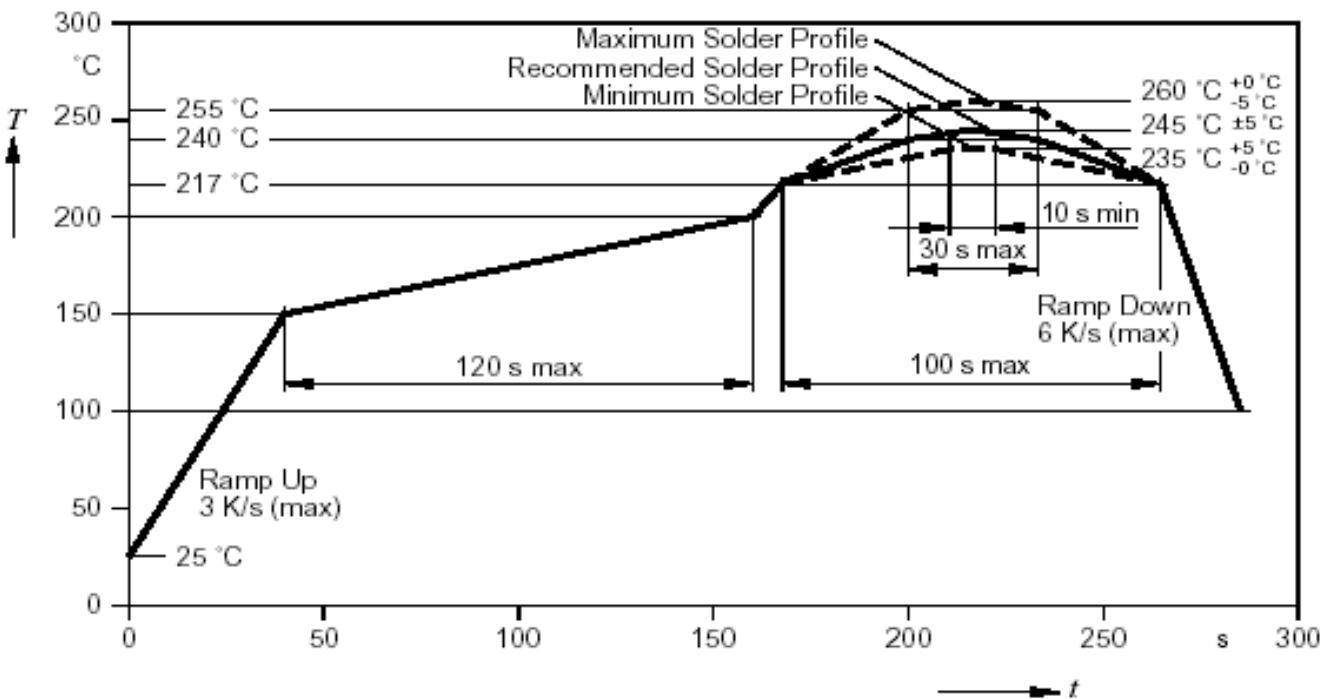



SURFACE MOUNT DEVICE LED

Part No. : L-T670LGCT

REV: A / 5

● CAUTIONS

1. Static Electricity:

* Static electricity or surge voltage damages the LEDs.

It is recommended that a wrist band or an anti-electrostatic glove be used when handling the LEDs.

* All devices, equipment and machinery must be properly grounded.

It is recommended that measures be taken against surge voltage to the equipment that mounts the LEDs.

* When inspecting the final products in which LEDs were assembled, it is recommended to check whether the assembled LEDs are damaged by static electricity or not. It is easy to find static-damaged LEDs by a light-on test or a VF test at a lower current (blew 1mA is recommended).

* Damaged LEDs will show some unusual characteristics such as the leak current remarkably increases, the forward voltage becomes lower, or the LEDs do not light at the low current.

Criteria: (VF>2.0V, at IF=0.5mA)

2. Storage :

* Before opening the package :

The LEDs should be kept at 30°C or less and 85%RH or less. When storing the LEDs, moisture proof packaging with absorbent material (silica gel) is recommended.

* After opening the package :

The LEDs should be kept at 30°C or less and 70%RH or less. The LEDs should be soldered within 168 hours (7 days) after opening the package. If unused LEDs remain, they should be stored in moisture proof packages, such as sealed containers with packages of moisture absorbent material (silica gel). It is also recommended to return the LEDs to the original moisture proof bag and to reseal the moisture proof bag again.

If the moisture absorbent material (silica gel) has faded away or the LEDs have exceeded the storage time, baking treatment should be performed using the following conditions.

Baking treatment: more than 24hours at 65±5°C .

* Please avoid rapid transitions in ambient temperature in high humidity environments where condensation may occur.

3. Soldering:

Do not apply any stress to the LED lens during soldering while the LED is at high temperature.

Recommended soldering condition.

* Reflow Soldering :

Pre-heat 120~150°C, 120sec. MAX., Peak temperature : 240°C Max. Soldering time : 10 sec Max.

* Soldering Iron : (Not recommended)

Temperature 350°C Max., Soldering time : 3 sec. Max.(one time only), power dissipation of iron :

20W Max. use SN60 solder of solder with silver content and don't touch LED lens when soldering.



SURFACE MOUNT DEVICE LED

Part No. : L-T670LGCT

REV: A / 5

4. Lead-Free Soldering

For Reflow Soldering :

- 1、Pre-Heat Temp: 150-180°C,120sec.Max.
- 2、Soldering Temp: Temperature Of Soldering Pot Over 240°C,40sec.Max.
- 3、Peak Temperature: 260°C , 10sec.
- 4、Reflow Repetition: 2 Times Max.
- 5、Suggest Solder Paste Formula : 93.3 Sn/3.1 Ag/3.1 Bi/0.5 Cu

For Soldering Iron (Not Recommended) :

- 1、Iron Tip Temp: 350°C Max.
- 2、Soldering Iron: 30w Max.
- 3、Soldering Time: 3 Sec. Max. One Time.

5. Drive Method

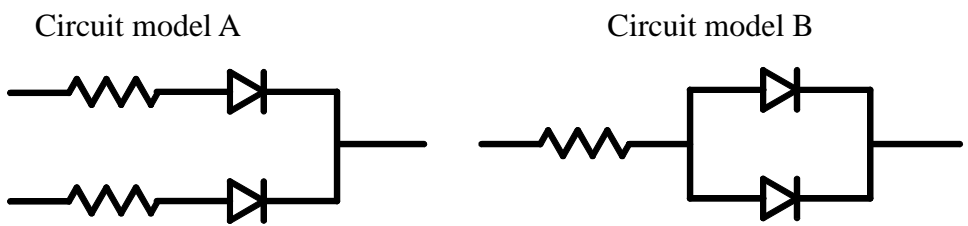

(A)Recommended circuit.

(B)The difference of brightness between LED`s could be found due to the Vf-If characteristics of LED.

6. Reliability

1、Criteria For Judging The Damage

Item	Symbol	Test Conditions	Criteria for Judgement	
			MIN.	Max.
Forward Voltage	V _F	I _F =20mA	-	U.S.L.*)×1.1
Reverse Current	I _R	V _R =5V	-	U.S.L.*)×2.0
Luminous Intensity	I _V	I _F =20mA	L.S.L.**))×0.7	-

*) U.S.L.: Upper Standard Level

**)) L.S.L: Lower Standard Level



SURFACE MOUNT DEVICE LED

Part No. : L-T670LGCT

REV: A / 5

2、 Test Items And Results

Test Item	Reference Standard	Test Condition	Note	Number of Damaged
Resistance to Soldering Heat (Reflow Soldering)	JEITA ED-4701300 301	Tsld=260°C,10sec. (Pre treatment 30°C,70%,168hrs)	2times	0/50
Solder ability (Reflow Soldering)	JEITA ED-4701300 303	Tsld=215°C,3sec. (Lead Solder)	1time over 95%	0/50
Thermal Shock	JEITA ED-4701300 307	-40°C ~ 100°C 30min. 30min.	100cycles	0/50
Temperature Cycle	JEITA ED-4701100 105	-40°C ~ 25°C~100°C~25°C 30min. 5min. 30min. 5min	100cycles	0/50
High Temperature Storage	JEITA ED-4701200-201	Ta=100°C	1000hrs.	0/50
Temperature Humidity Storage	JEITA ED-4701100 103	Ta=60°C,RH=90%	1000hrs.	0/50
Low Temperature Storage	JEITA ED-4701200 202	Ta=-40°C	1000hrs.	0/50
Steady State Operating Life Condition		Ta=25°C,IF=20mA	1000hrs.	0/50
Steady State Operating Life of High Temperature		Ta=85°C,IF=5mA	500hrs.	0/50
Steady State Operating Life of High Humidity Heat		Ta=60°C,RH=90%,IF=15mA	500hrs.	0/50
Steady State Operating Life of Low Temperature		Ta=-30°C,IF=20mA	500hrs.	0/50
Vibration	JEITA ED-4701400 403	100~2000~100HzSweep 4min.200m/s ² 3direction,4cycles	48min	0/50
Substrate Bending	JEITA ED-4702	3mm,5±1sec	1time	0/50
Stick	JEITA ED-4702	5N,10±1sec	1time	0/50

7.Others:

The appearance and specifications of the product may be modified for improvement without notice.



SURFACE MOUNT DEVICE LED

Part No. : L-T670LGCT

REV: A / 5

● PART NO. SYSTEM :

L - T 670 X X T - X X X X

XXXX : Special specification for customer

T : Taping for 7 inch reel
TC : Taping for 13 inch reel

Lens color
C : Water Clear
W : White Diffused
T : Color Transparent
D : Color Diffused

KY : 9mil AlInGap 590nm Super Yellow
KR : 9mil AlInGap 630 nm Super Red
TE : 14mil AlInGap 624 nm Super Red
TY: 14mil AlInGap590 nm Super Yellow
LB : InGaN ITO rough 470nm Blue
LG : InGaN ITOrough520nm Green
W : InGaN + YAG White color
.....

0 : Single chip
1/2 : Super thin single chip
5/6 : Dual chip
F : Three chip(Full color)

650 : 3020 1.3T TYPE
670 : 3528 1.9T TYPE
020 : 3812 0.6T TYPE

C : PCB Top View Type
T : PLCC Top View Type
S : Side View Type