

## A 30 WATT, 800 MHz AMPLIFIER DESIGN

Prepared by: Alan Wood  
Semiconductor Product Sector

### INTRODUCTION

Simplicity and compactness mark the design of this 30 Watt amplifier designed for the 800 MHz mobile communications band. The amplifier uses the internally matched MRF844 transistor in a common base Class C configuration providing a minimum of 5.0 dB gain over a fixed tuned bandwidth of 800 to 870 MHz at 12.5 volts. Lower manufacturing costs are of prime concern to land mobile equipment suppliers and single-board, fixed tuned transmitter amplifier designs are becoming increasingly common. Two versions are therefore presented, one using glass teflon laminate and the second using less expensive G-10 board. (Figure 1).

### CIRCUIT DESCRIPTION

The circuit is designed to be driven from a 50 ohm source and be terminated in a nominal 50 ohm load. Both input and output matching networks are similar in design and consist of two element short-step Chebyshev transmission line transformations fabricated as microstrip lines (Reference 1). Mini-Underwood mica capacitors are used at the input and output of the transistor transforming the complex inductive impedance to an essentially non-reactive real impedance over most of the band. A minimum of additional components provide the dc biasing and RF decoupling. Refer to Figure 2 for a schematic diagram of the amplifier .

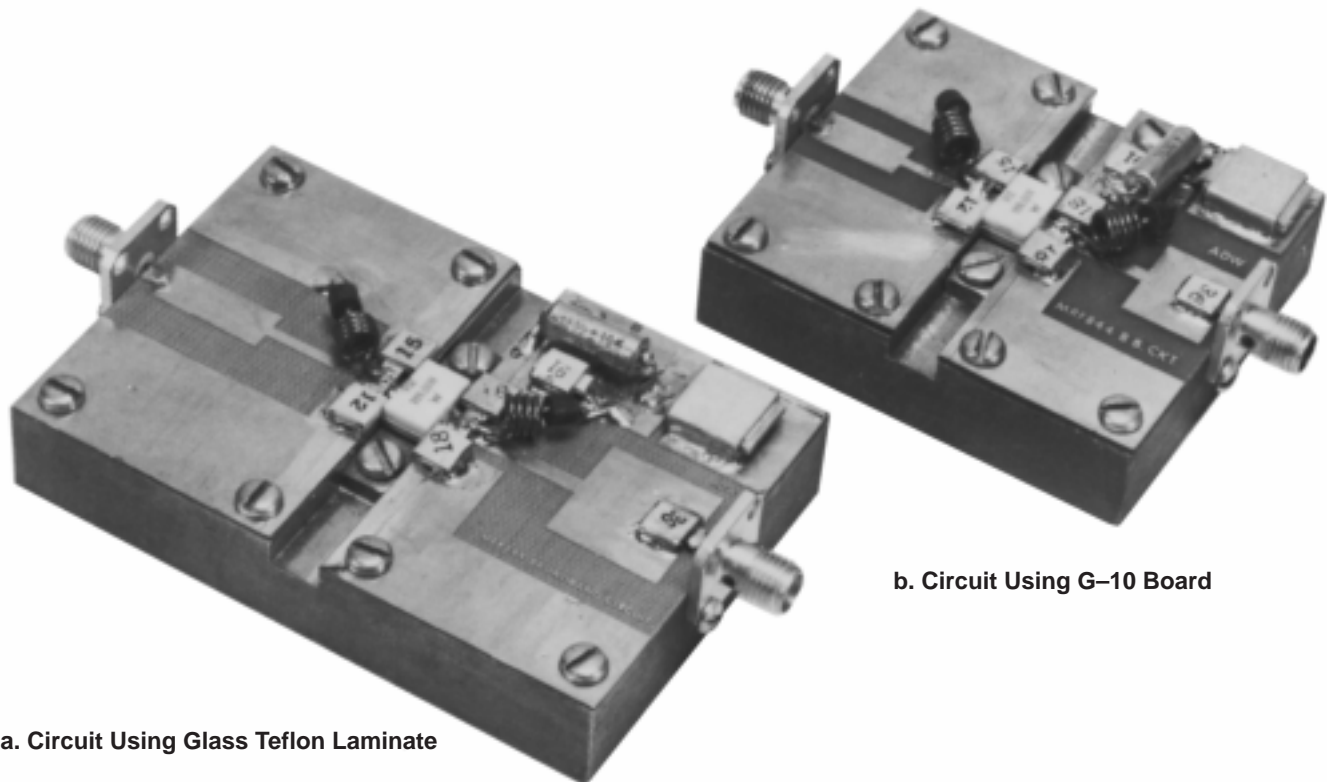
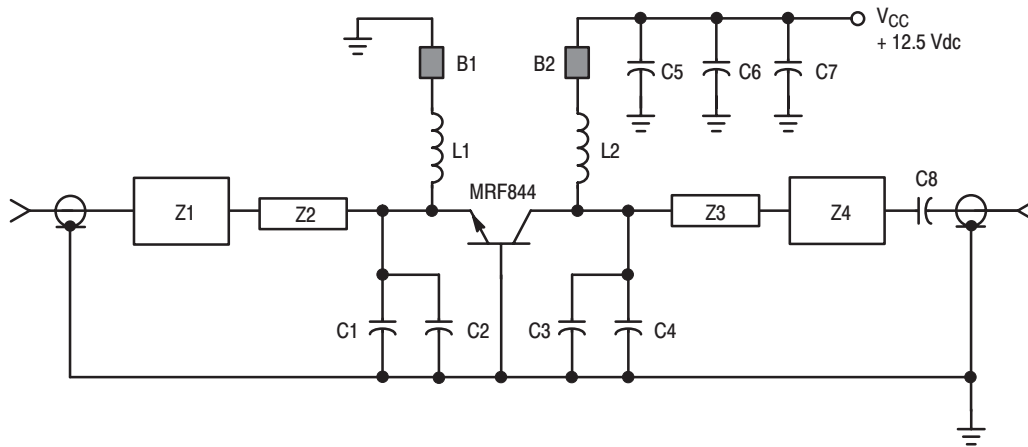

Figure 1. Two Versions of MRF844 Broadband Circuit



- B1, B2 — Ferroxcube Bead 56-590-65/3B
- C1 — 15 pF Mini-Underwood Mica
- C2 — 12 pF Mini-Underwood Mica
- C3, C4 — 18pF Mini-Underwood Mica
- C5 — 91 pF Mini-Underwood Mica
- C6 — 1000 pF Unelco Mica
- C7 — 1.0 μF Electrolytic
- C8 — 36 pF Mini-Underwood Mica
- L1, L2 — 4 Turns, #20 AWG Enameled Wire 0.15" ID
- Z1 – Z4 — Microstrip; See Photomasters
- Board Material — See Text

Figure 2. Circuit Schematic of 30 Watt 806 – 870 MHz Amplifier

Design of microstrip circuits using a G-10 board material is complicated by several factors. This is discussed in detail in Reference 2. The main points to be considered are, the lack of control over the dielectric constant in the manufacturing process; a greater tolerance in the dielectric thickness than in the case of higher quality substrates intended for microstrip applications, and changes in relative dielectric constant with frequency. Despite these apparent disadvantages, G-10 board can be used successfully if the ultimate in bandwidth is not sought.

Frequency dependence of the relative dielectric constant was determined by characterizing a nominal 25 ohm microstrip line over a wide range of frequencies using an automatic network analyser. Compensation for the coaxial to microstrip transitions was established using a computer optimized model (Reference 3). Figure 3 is a graph of the relative dielectric constant versus frequency determined for the laminate used by this method. It should be noted that differences in epoxy composition could affect both the low frequency dielectric constant and its frequency dependence.

**CONSTRUCTION PROCEDURES**

Both amplifiers were mounted on 0.5" thick copper blocks, 2.25" by 2" in the case of the G-10 board design and 3" by 2" for the glass teflon board. The blocks were slotted to a depth of 0.130" to enable mounting the transistor leads level with the top of the circuit board. Thermal compound was used between the transistor flange and the mounting block to ensure low thermal resistance. With the block held in contact with a larger heatsink this configuration proved adequate for test purposes. In a production design, the

transistor would normally be thermally connected to the case of the transmitter. However, care should be taken to operate the device under all conditions within the Power Dissipation limits shown on the data sheet.

As with any circuit designed to work at UHF frequencies, good grounding is essential for best performance and stability. Copper foil was wrapped around the board adjacent to the transistor mounting to connect the underside ground plane to the transistor common leads. Additional copper foil was wrapped around the board to connect the 1000 pF Unelco capacitor pad to the lower ground plane.

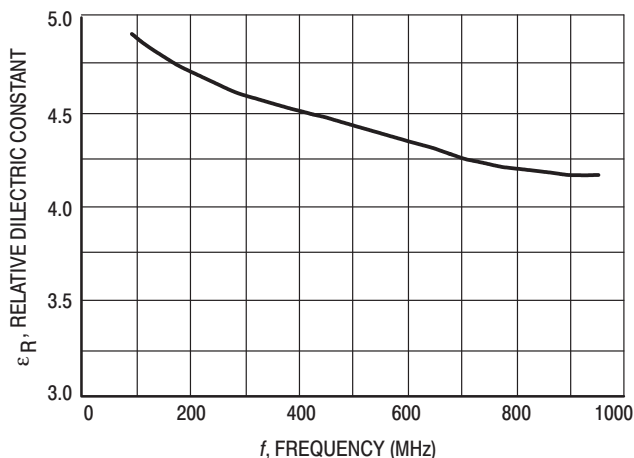

Figure 3. Relative Dielectric Constant (G-10) versus Frequency

Positioning of the emitter and collector shunt capacitors is critical to the resulting amplifier performance. The capacitors should be mounted as close to the transistor case as possible. Minor tuning of the circuit can be achieved by lateral movement of these components. Larger tuning adjustments can be incorporated by replacing part of the fixed shunt capacitance by a variable trimmer.

Both circuits use 28 mil dielectric 2 ounce copper clad laminate. Refer to Figure 6 for a 1:1 Photomaster of the circuit boards.

PERFORMANCE DATA

Similar performance was measured for the same part soldered in either circuit. Typical performance curves for this broadband design are shown in Figures 4a, 4b, and 4c for the glass Teflon design and Figures 5a, 5b, and 5c for the G-10 based circuit. Circuit losses in the G-10 board were less than expected and were certainly minimized by the short fractional wavelength transmission lines employed.

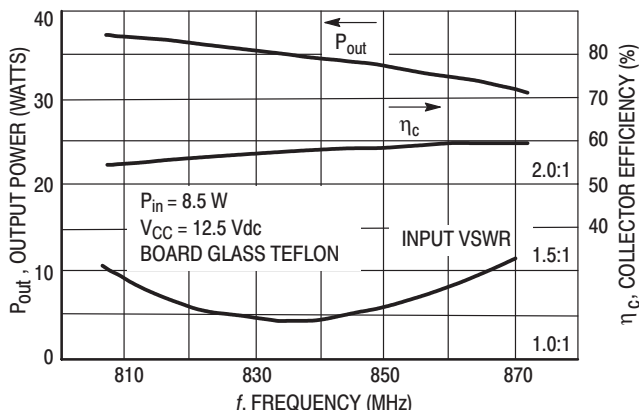

Figure 4a. Typical Performance in Broadband Circuit

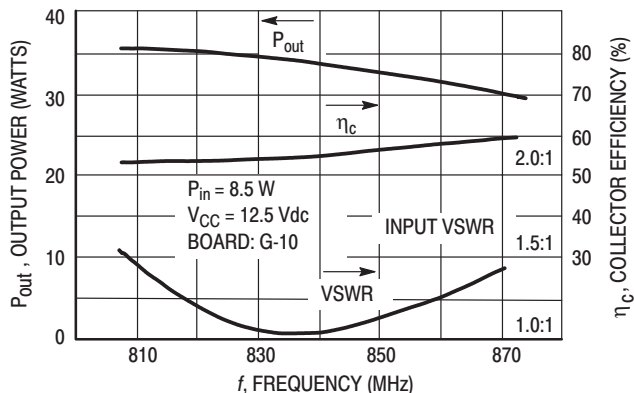

Figure 5a. Typical Performance in Broadband Circuit

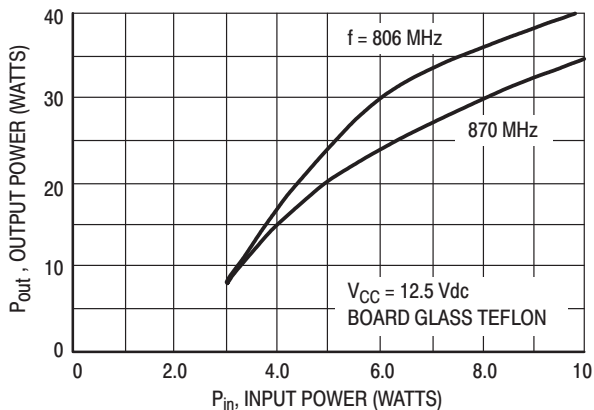

Figure 4b. Output Power versus Input Power

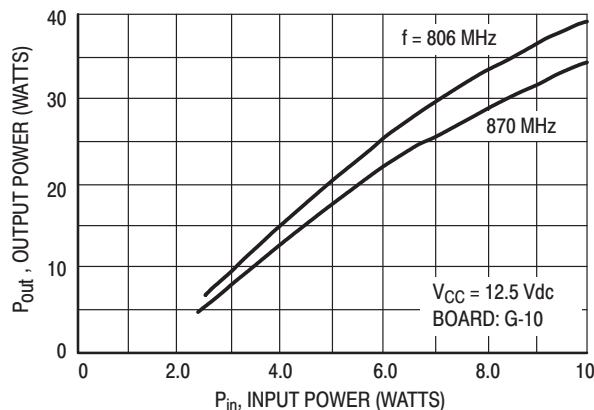

Figure 5b. Output Power versus Input Power

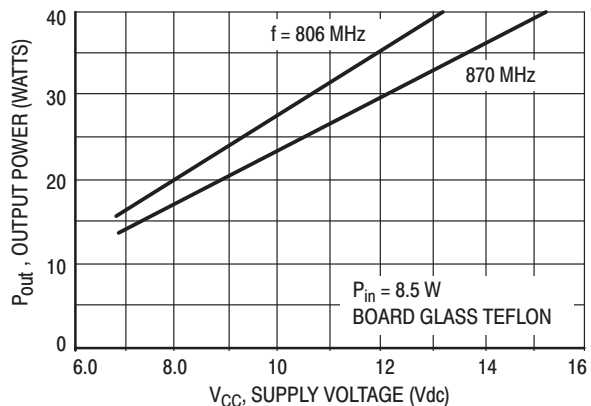

Figure 4c. Output Power versus Supply Voltage

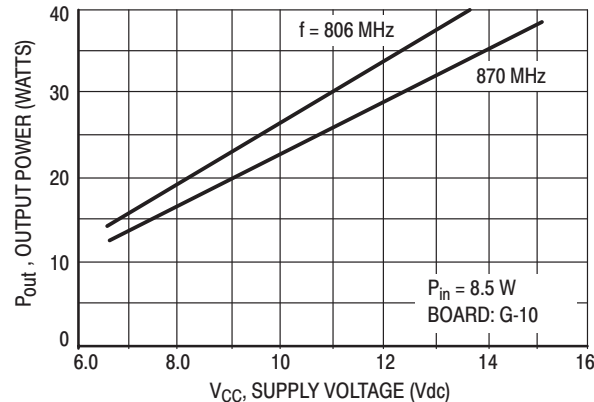
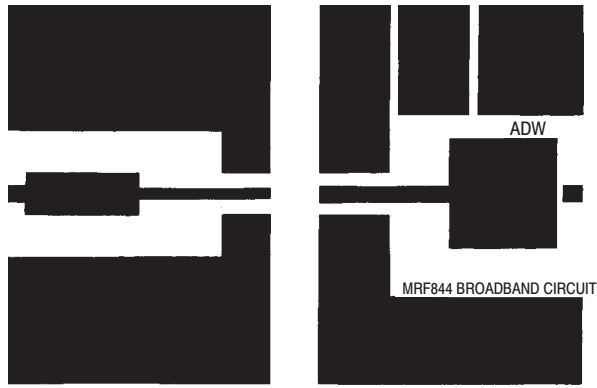
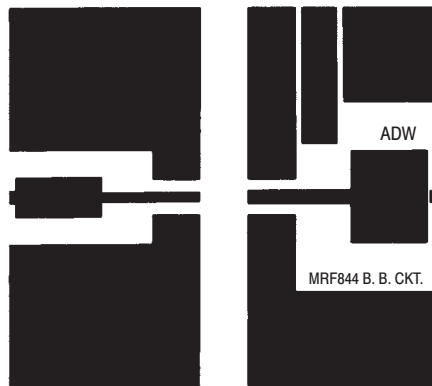

Figure 5c. Output Power versus Supply Voltage

NOTE: Not to Scale



a. Photomaster Using Glass Teflon Laminate



b. Photomaster Using G-10 Board

Figure 4. Two Photomaster Versions of MRF844 Broadband Circuit

REFERENCES

1. G. L. Mattheai. *Short-Step Impedance Transformers. IEEE Transactions on Microwave Theory and Techniques.* Vol. MTT-14 No. 8 August 1966.
2. Glenn Young. *UHF Microstrip Amplifiers Utilizing G-10 Epoxy Glass Laminate.* Motorola Application Note AN-578.
3. M. L. Majewski. *Modeling and Characterization of Microstrip to Co-axial Transitions. IEEE Transactions on Microwave Theory and Techniques.* Vol. MTT-29 No. 8 August 1981.

Motorola reserves the right to make changes without further notice to any products herein. Motorola makes no warranty, representation or guarantee regarding the suitability of its products for any particular purpose, nor does Motorola assume any liability arising out of the application or use of any product or circuit, and specifically disclaims any and all liability including without limitation consequential or incidental damages. "Typical" parameters can and do vary in different applications. All operating parameters, including "Typicals" must be validated for each customer application by customer's technical experts. Motorola does not convey any license under its patent rights nor the rights of others. Motorola products are not designed, intended, or authorized for use as components in systems intended for surgical implant into the body or other applications intended to support or sustain life, or for any other application in which the failure of the Motorola product could create a situation where personal injury or death may occur. Should Buyer purchase or use Motorola products for any such unintended or unauthorized application, Buyer shall indemnify and hold Motorola and its officers, employees, subsidiaries, affiliates, and distributors harmless against all claims, costs, damages, and expenses, and reasonable attorney fees arising out of, directly or indirectly, any claim of personal injury or death associated with such unintended or unauthorized use, even if such claim alleges that Motorola was negligent regarding the design or manufacture of the part. Motorola and  are registered trademarks of Motorola, Inc. Motorola, Inc. is an Equal Opportunity/Affirmative Action Employer.

**Literature Distribution Centers:**

USA: Motorola Literature Distribution; P.O. Box 20912; Phoenix, Arizona 85036.

EUROPE: Motorola Ltd.; European Literature Centre; 88 Tanners Drive, Blakelands, Milton Keynes, MK14 5BP, England.

JAPAN: Nippon Motorola Ltd.; 4-32-1, Nishi-Gotanda, Shinagawa-ku, Tokyo 141, Japan.

ASIA PACIFIC: Motorola Semiconductors H.K. Ltd.; Silicon Harbour Center, No. 2 Dai King Street, Tai Po Industrial Estate, Tai Po, N.T., Hong Kong.



**MOTOROLA**