



(0,80 mm) .0315"

SEAF8 SERIES



ULTRA HIGH DENSITY OPEN PIN FIELD

SPECIFICATIONS

For complete specifications and recommended PCB layouts see www.samtec.com?SEAF8

- Insulator Material:** Black LCP
- Contact Material:** Copper Alloy
- Operating Temp Range:** -55°C to +125°C
- Plating:** Au or Sn over 50µ" (1,27 µm) Ni
- Working Voltage:** 220 VAC
- RoHS Compliant:** Yes
- Lead-Free Solderable:** Yes

Mates with: SEAM8

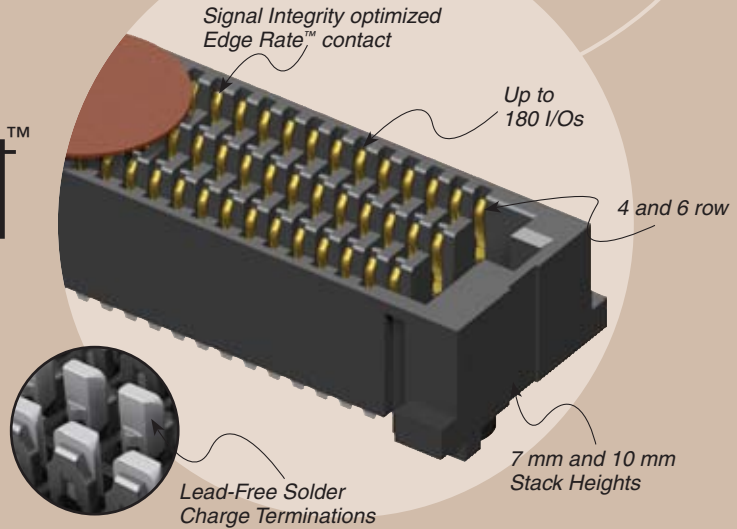

ALSO AVAILABLE

- Other pin counts in design.
- Call Samtec.

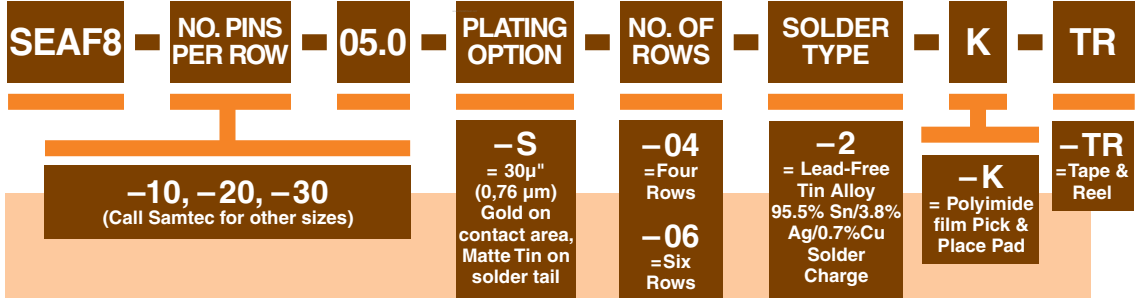

MATED HEIGHT*		
SEAF8 LEAD STYLE	SEAM8 LEAD STYLE	
	-S02.0	-S05.0
-05.0	(7,00) .276	(10,00) .394

*Processing conditions will affect mated height.

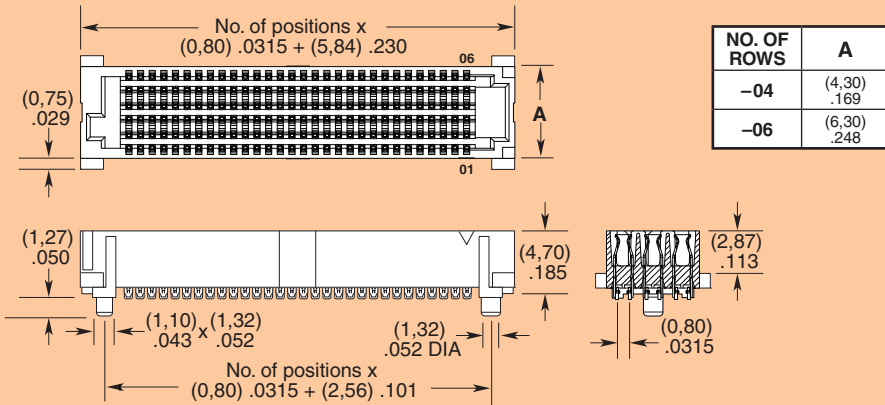

Note: Some sizes, styles and options are non-standard, non-returnable.

Due to technical progress, all designs, specifications and components are subject to change without notice.

WWW.SAMTEC.COM