

## Fact Sheet

### SMART NETWORK DESIGNS

### SMART PACKET TELEPHONY 8101

# Freescale Semiconductor, Inc.



As the communications industry migrates from circuit-switched to packet-centric infrastructure, equipment manufacturers require systems solutions that include comprehensive design tools, signal processing, the ability to interface with both packet- and circuit-switched networks, control and signaling functions, and software support.

The first in a series of integrated, yet flexible, packet telephony system solutions from Motorola, Smart Packet Telephony 8101 is a hardware reference design for medium-size media gateway equipment that can handle voice, fax or modem data services.

The reference platform and development kit are ultimately designed to give manufacturers of remote access servers (RAS) and IP-PBXs that are based on MSC8100 DSPs a significant time-to-market advantage. At the front end of the design process, system architects may use this scalable evaluation platform to assess the capabilities of the StarCore® architecture-based MSC8100 DSPs and establish suitability for their end product. Since it is a comprehensive hardware reference design, it is also designed to facilitate rapid system development. Multiple third parties supply media gateway and remote access server software to complete the packet telephony solution.

The development platform includes support for voice compression and echo cancellation, essential for voice-over-packet systems. Smart Packet Telephony 8101 consists of three main subsystems. The MPC8260 baseboard is designed to support Fast Ethernet

interfaces to the packet network; is designed to provide a UTOPIA level-2 interface and H.100 TDM interface; and is designed to run essential application-specific protocols required by the target application.

The DSP subsystem is designed to run essential signal processing functions for voice, fax and modem data applications. At the heart of the DSP subsystem are six MSC8101 DSPs in a PTMC form factor. Typical functions include voice compression, DTMF detection, voice activity detection, echo cancellation and silence suppression, as well as modem and fax data modulation and demodulation. The DSP subsystem interfaces to the MPC8260 baseboard via the MSC8101's 60x bus. The POTS subsystem connects to the DSP subsystem, and it offers four narrow-band T1/E1 TDM ports. The POTS subsystem is also designed to support four analog POTS ports for direct interfaces to standard analog voice terminals, and it provides a TDM stream for the DSP array.

Reference Design Overview (with future expansion cards)

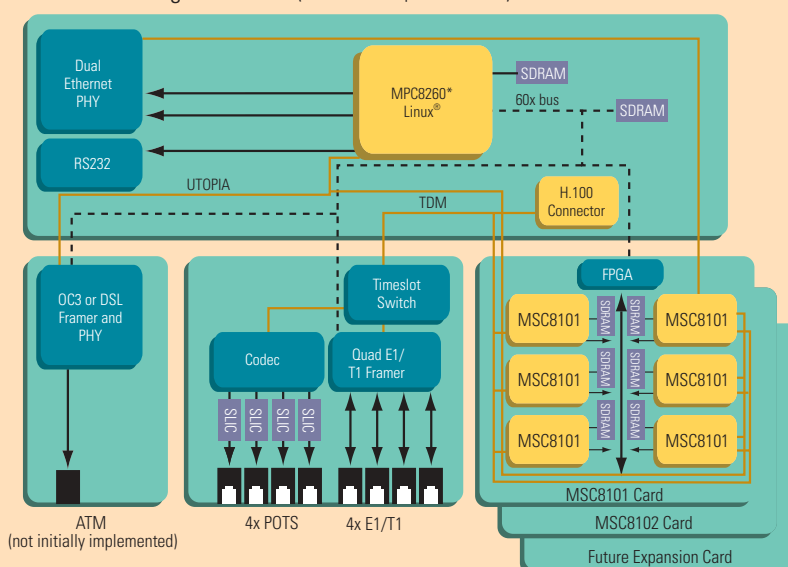

\* The MPC8260 contains a PowerPC® processor core.

**For More Information On This Product,  
Go to: [www.freescale.com](http://www.freescale.com)**

*Smart Packet  
Telephony 8101 is  
designed to enable  
fast software and  
hardware  
development  
on a proven  
hardware platform.*

**HARDWARE PRODUCT FEATURES**

- DSP daughter card with six MSC8101 DSPs
- MPC8260 baseboard
- Four E1/T1 interfaces—terminate up to 128 PSTN or PBX DS-0s
- Four POTS ports—terminate up to four analog POTS lines or trunks
- H.100 connection
- Two 10/100 Base-T Ethernet ports
- One Utopia level-2 interface capable of bit rates of up to 155 Mbps
- One RS-232 craft or management port
- JTAG debug port

**SOFTWARE PRODUCT FEATURES**

- Driver libraries for MPC8260 and MSC8101
- Board-level diagnostics
- MPC8260 U-Boot bootloader
- MPC8260 Linux® operating system support through Metrowerks
- Multiple third parties supplying media gateway and remote access server software for this packet telephony solution
- Motorola component-level demonstrator available

**KEY ADVANTAGES**

- Full packet telephony reference design for IP-PBX with schematics for fast time-to-market
- Evaluation kit for proof of concept
- Modular solution supports future expansion via PTMC form factor daughter cards



MOTOROLA and the Stylized M Logo are registered in the U.S. Patent and Trademark Office. Metrowerks, the Metrowerks logo, and CodeWarrior are registered trademarks of Metrowerks Corp. in the U.S. and/or other countries. The "PowerPC" name is a trademark of IBM Corp. and used under license. All other product or service names are the property of their respective owners.  
© Motorola, Inc. 2003

PACKTELE8101FS/D

**For More Information On This Product,  
Go to: [www.freescale.com](http://www.freescale.com)**