



Le58QL02/021/031

Quad Low Voltage Subscriber Line Audio-Processing Circuit VE580 Series

APPLICATIONS

- Codec function on telephone switch line cards

FEATURES

- Low-power, 3.3 V CMOS technology with 5-V tolerant digital inputs
- Software and coefficient compatible to the Le79Q02/021/031 QSLAC™ device
- Performs the functions of four codec/filters
- Software programmable:
 - SLIC device input impedance
 - Transhybrid balance
 - Transmit and receive gains
 - Equalization (frequency response)
 - Digital I/O pins
 - Programmable debouncing on one input
 - Time slot assigner
 - Programmable clock slot and PCM transmit clock edge options
- Standard microprocessor interface
- A-law, μ -law, or linear coding
- Single or Dual PCM ports available
 - Up to 128 channels (PCLK at 8.192 MHz) per PCM port
 - Optional supervision on the PCM highway
- 1.536, 1.544, 2.048, 3.072, 3.088, 4.096, 6.144, 6.176, or 8.192 MHz master clock derived from MCLK or PCLK
- Built-in test modes with loopback, tone generation, and μ P access to PCM data
- Mixed state (analog and digital) impedance scaling
- Performance guaranteed over a 12 dB gain range
- Real Time Data register with interrupt (open drain or TTL output)
- Supports multiplexed SLIC device outputs
- Broadcast state
- 256 kHz or 293 kHz chopper clock for Legerity SLIC devices with switching regulator
- Maximum channel bandwidth for V.90 modems

RELATED LITERATURE

- 080754 Le58QL061/063 QLSLAC™ Device Data Sheet
- 080761 QSLAC™ to QLSLAC™ Device Design Conversion Guide
- 080758 QSLAC™ to QLSLAC™ Guide to New Designs

ORDERING INFORMATION

Device	Package (Green) ¹	Packing ²
Le58QL02FJC	44-pin PLCC	Tube
Le58QL021FJC	44-pin PLCC	Tube
Le58QL021BVC	44-pin TQFP	Tray
Le58QL031DJC	32-pin PLCC	Tube

1. The green package meets RoHS Directive 2002/95/EC of the European Council to minimize the environmental impact of electrical equipment.
2. For delivery using a tape and reel packing system, add a "T" suffix to the OPN (Ordering Part Number) when placing an order.

DESCRIPTION

The Le58QL02/021/031 Quad Low Voltage Subscriber Line Audio-Processing Circuit (QLSLAC™) devices integrate the key functions of analog line cards into high-performance, very-programmable, four-channel codec-filter devices. The QLSLAC devices are based on the proven design of Legerity's reliable SLAC™ device families. The advanced architecture of the QLSLAC devices implements four independent channels and employs digital filters to allow software control of transmission, thus providing a cost-effective solution for the audio-processing function of programmable line cards. The QLSLAC devices are software and coefficient compatible to the QSLAC devices.

Advanced submicron CMOS technology makes the Le58QL02/021/031 QLSLAC devices economical, with both the functionality and the low power consumption needed in line card designs to maximize line card density at minimum cost. When used with four Legerity SLIC devices, a QLSLAC device provides a complete software-configurable solution to the BORSCHT functions.

BLOCK DIAGRAM

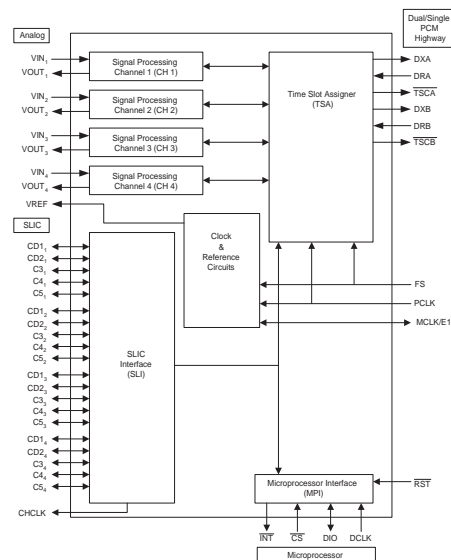

Table of Contents

APPLICATIONS	1
FEATURES	1
ORDERING INFORMATION	1
RELATED LITERATURE	1
DESCRIPTION	1
BLOCK DIAGRAM	1
PRODUCT DESCRIPTION	5
BLOCK DESCRIPTIONS	5
Clock and Reference Circuits	5
Microprocessor Interface (MPI)	5
Time Slot Assigner (TSA)	5
Signal Processing Channels (CHx)	5
SLIC Device Interface (SLI)	5
CONNECTION DIAGRAMS	6
PIN DESCRIPTIONS	9
ABSOLUTE MAXIMUM RATINGS	11
OPERATING RANGES	11
Environmental Ranges	11
Electrical Ranges	11
ELECTRICAL CHARACTERISTICS	12
Transmission Characteristics	13
Attenuation Distortion	14
Group Delay Distortion	15
Gain Linearity	16
Total Distortion Including Quantizing Distortion	17
Discrimination Against Out-of-Band Input Signals	18
Discrimination Against 12- and 16-kHz Metering Signals	18
Spurious Out-of-Band Signals at the Analog Output	19
Overload Compression	20
SWITCHING CHARACTERISTICS	21
SWITCHING WAVEFORMS	23
OPERATING THE QLSLAC DEVICE	26
Power-Up Sequence	26
Channel Enable (EC) Register	26
SLIC Device Control and Data Lines	26
Clock Mode Operation	26
E1 Multiplex Operation	27
Debounce Filters Operation	29
Real-Time Data Register Operation	30
Interrupt	30
Interrupt Mask Register	31
Active State	31
Inactive State	31
Chopper Clock	31
Reset States	31
SIGNAL PROCESSING	32
Overview of Digital Filters	32
Two-Wire Impedance Matching	32
Frequency Response Correction and Equalization	32
Transhybrid Balancing	32

Gain Adjustment	33
Transmit Signal Processing	33
Transmit PCM Interface	33
Receive Signal Processing	33
Receive PCM Interface	34
Analog Impedance Scaling Network (AISN)	34
Speech Coding	34
Signaling on the PCM Highway	35
Robbed-Bit Signaling Compatibility	35
Default Filter Coefficients	36
COMMAND DESCRIPTION AND FORMATS	37
Command Field Summary	37
Microprocessor Interface Description	38
SUMMARY OF MPI COMMANDS	39
MPI COMMAND STRUCTURE	39
00h Deactivate (Standby State)	40
02h Software Reset	40
04h Hardware Reset	40
06h No Operation	40
0Eh Activate Channel (Operational State)	40
40/41h Write/Read Transmit Time Slot and PCM Highway Selection	41
42/43h Write/Read Receive Time Slot and PCM Highway Selection	41
44/45h Write/Read Transmit Clock Slot, Receive Clock Slot, and Transmit Clock Edge	41
46/47h Write/Read Chip Configuration Register	42
4A/4Bh Write/Read Channel Enable and Operating Mode Register	43
4D/4Fh Read Real-Time Data Register	43
50/51h Write/Read AISN and Analog Gains	44
52/53h Write/Read SLIC Device Input/Output Register	44
54/55h Write/Read SLIC Input/Output Direction, Read Status Bits	44
60/61h Write/Read Operating Functions	45
6C/6Dh Write/Read Interrupt Mask Register	46
70/71h Write/Read Operating Conditions	46
73h Read Revision Code Number (RCN)	47
80/81h Write/Read GX Filter Coefficients	47
82/83h Write/Read GR Filter Coefficients	47
84/85h Write/Read Z Filter Coefficients (FIR and IIR)	48
86/87h Write/Read B1 Filter Coefficients	49
88/89h Write/Read X Filter Coefficients	50
8A/8Bh Write/Read R Filter Coefficients	51
96/97h Write/Read B2 Filter Coefficients (IIR)	52
98/99h Write/Read FIR Z Filter Coefficients (FIR only)	52
9A/9Bh Write/Read IIR Z Filter Coefficients (IIR only)	53
C8/C9h Write/Read Debounce Time Register	53
CDh Read Transmit PCM Data	54
E8/E9h Write/Read Ground Key Filter	54
PROGRAMMABLE FILTERS	55
General Description of CSD Coefficients	55
User Test States and Operating Conditions	56
A-Law and μ -Law Companding	56
APPLICATIONS	59
Controlling the SLIC Device	59
Calculating Coefficients with WinSLAC Software	59
APPLICATION CIRCUIT	60
LINE CARD PARTS LIST	60
PHYSICAL DIMENSIONS	61

32-Pin PLCC61
44-Pin PLCC62
44-Pin TQFP63
REVISION HISTORY64
Revision A1 to A264
Revision A2 to B164
Revision B1 to C164
Revision C1 to D164
Revision D1 to E164
Revision E1 to F164

List of Figures

Figure 1. Le58QL02JC 44-Pin PLCC6
Figure 2. Le58QL021JC 44-Pin PLCC7
Figure 3. Le58QL031JC 32-Pin PLCC7
Figure 4. Le58QL021VC 44-Pin PLCC8
Figure 5. Transmit Path Attenuation vs. Frequency14
Figure 6. Receive Path Attenuation vs. Frequency14
Figure 7. Group Delay Distortion15
Figure 8. A-law Gain Linearity with Tone Input (Both Paths)16
Figure 9. μ -law Gain Linearity with Tone Input (Both Paths)16
Figure 10. Total Distortion with Tone Input (Both Paths)17
Figure 11. Discrimination Against Out-of-Band Signals18
Figure 12. Spurious Out-of-Band Signals19
Figure 13. Analog-to-Analog Overload Compression20
Figure 14. Input and Output Waveforms for AC Tests23
Figure 15. Microprocessor Interface (Input Mode)23
Figure 16. Microprocessor Interface (Output Mode)24
Figure 17. PCM Highway Timing for XE = 0 (Transmit on Negative PCLK Edge)24
Figure 18. PCM Highway Timing for XE = 1 (Transmit on Positive PCLK Edge)25
Figure 19. Master Clock Timing25
Figure 20. Clock Mode Options27
Figure 21. SLIC Device I/O E1 Multiplex and Real-Time Data Register Operation28
Figure 22. E1 Multiplex Internal Timing29
Figure 23. MPI Real-Time Data Register30
Figure 24. QLSLAC Device Transmission Block Diagram32
Figure 25. Robbed-Bit Frame36
Figure 26. Le7920 SLIC/QLSLAC Device Application Circuit60

List of Tables

Table 1. QLSLAC Device Configurations5
Table 2. 0 dBm0 Voltage Definitions with Unity Gain in X, R, GX, GR, AX, and AR13
Table 3. Channel Parameters37
Table 4. Channel Monitors38
Table 5. Global Chip Parameters38
Table 6. Global Chip Status Monitors38
Table 7. A-Law: Positive Input Values57
Table 8. μ -Law: Positive Input Values58

PRODUCT DESCRIPTION

The QLSLAC device performs the codec/filter and two-to-four-wire conversion functions required of the subscriber line interface circuitry in telecommunications equipment. These functions involve converting audio signals into digital PCM samples and converting digital PCM samples back into audio signals. During conversion, digital filters are used to band limit the voice signals. All of the digital filtering is performed in digital signal processors operating from a master clock, which can be derived either from PCLK or MCLK.

Four independent channels allow the QLSLAC device to function as four SLAC™ devices. For programming information, each channel has its own enable bit (EC1, EC2, EC3, and EC4) to allow individual channel programming. If more than one Channel Enable bit is High or if all Channel Enable bits are High, all channels enabled will receive the programming information written; therefore, a Broadcast mode can be implemented by simply enabling all channels in the device to receive the information. The Channel Enable bits are contained in the Channel Enable (EC) register, which is written and read using Command 4A/4Bh. The Broadcast mode is useful in initializing QLSLAC devices in a large system.

The user-programmable filters set the receive and transmit gain, perform the transhybrid balancing function, permit adjustment of the two-wire termination impedance, and provide equalization of the receive and transmit paths. All programmable digital filter coefficients can be calculated using the WinSLAC™ software.

Data transmitted or received on the PCM highway can be 8-bit companded code (with an optional 8-bit signaling byte in the transmit direction) or 16-bit linear code. The 8-bit codes appear 1 byte per time slot, while the 16-bit code appears in two consecutive time slots. The compressed PCM codes can be either 8-bit companded A-law or μ -law. The PCM data is read from and written to the PCM highway in user-programmable time slots at rates of 128 kHz to 8.192 MHz. The transmit clock edge and clock slot can be selected for compatibility with other devices that can be connected to the PCM highway.

Three configurations of the QLSLAC device are offered with single or dual PCM highways. The Le58QL02 and Le58QL021 QLSLAC devices with dual and single PCM highways respectively are available in the 44-pin packages. The Le58QL031JC QLSLAC device is a single PCM highway version in a 32-pin PLCC package.

Table 1. QLSLAC Device Configurations

PCM Highway	Programmable I/O per Channel	Chopper Clock	Package	Part Number
Dual	Four I/O	Yes	44 PLCC	Le58QL02JC
Single	Five I/O	No	44 PLCC/TQFP	Le58QL021JC (or VC)
Single	Two I/O	No	32 PLCC	Le58QL031JC

BLOCK DESCRIPTIONS

Clock and Reference Circuits

This block generates a master clock and a frame sync signal for the digital circuits. It also generates an analog reference voltage for the analog circuits.

Microprocessor Interface (MPI)

This block communicates with the external control microprocessor over a serial interface. It passes user control information to the other blocks, and it passes status information from the blocks to the user. In addition, this block contains the reset circuitry.

Time Slot Assigner (TSA)

This block communicates with the PCM highway, where the PCM highway is a time division multiplexed bus carrying the digitized voice samples. The block implements programmable time slots and clocking arrangements in order to achieve a first layer of switching. Internally, this block communicates with the Signal Processing Channels (CHx).

Signal Processing Channels (CHx)

These blocks do the transmission processing for the voice channels. Part of the processing is analog and is interfaced to the VIN and VOUT pins. The remainder of the processing is digital and is interfaced to the Time Slot Assigner (TSA) block.

SLIC Device Interface (SLI)

This block communicates digitally with the SLIC device circuits. It sends control bits to the SLIC devices to control modes and to operate LEDs and optocouplers. It also accepts supervision information from the SLIC devices and performs some filtering.

CONNECTION DIAGRAMS

Figure 1. Le58QL02JC 44-Pin PLCC

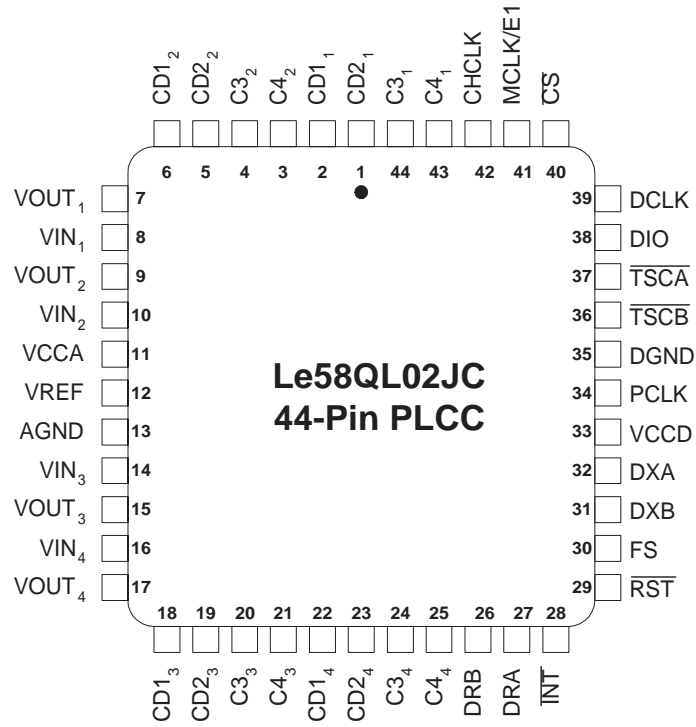

Figure 2. Le58QL021JC 44-Pin PLCC

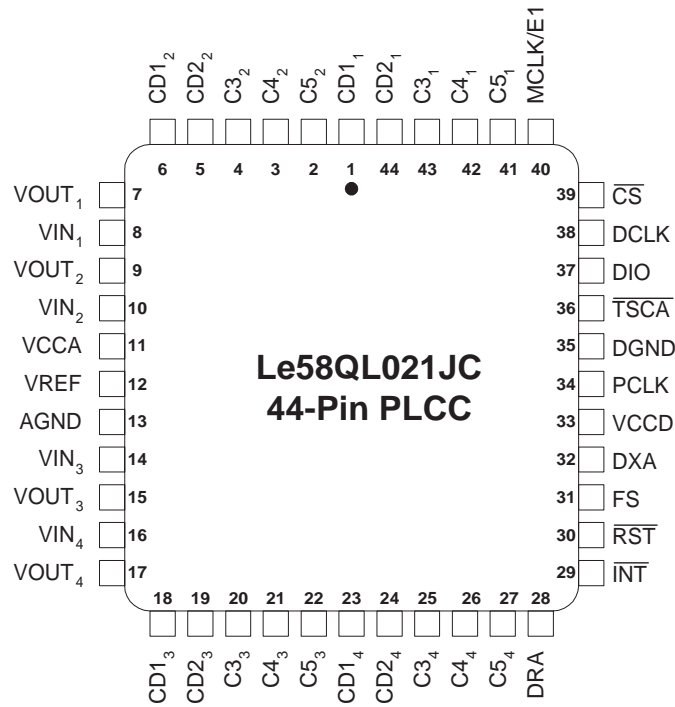

Figure 3. Le58QL031JC 32-Pin PLCC

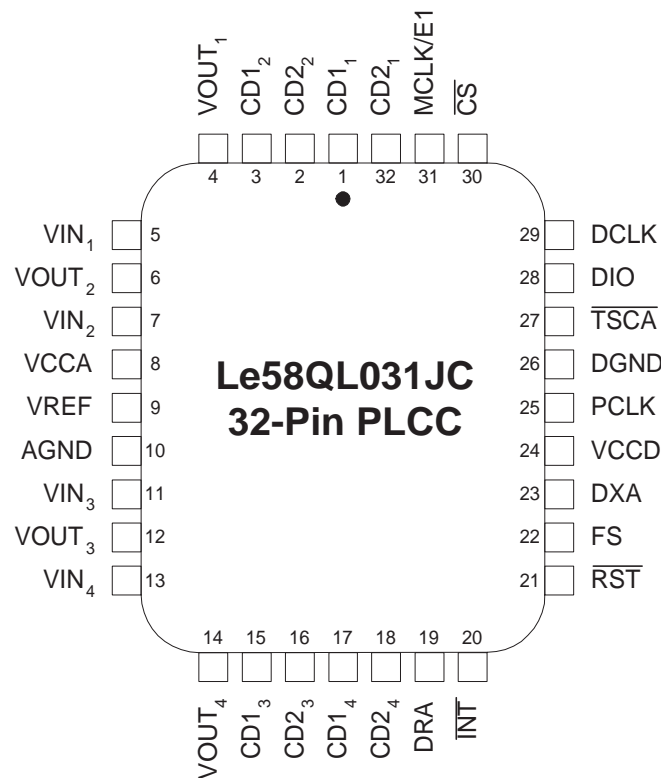
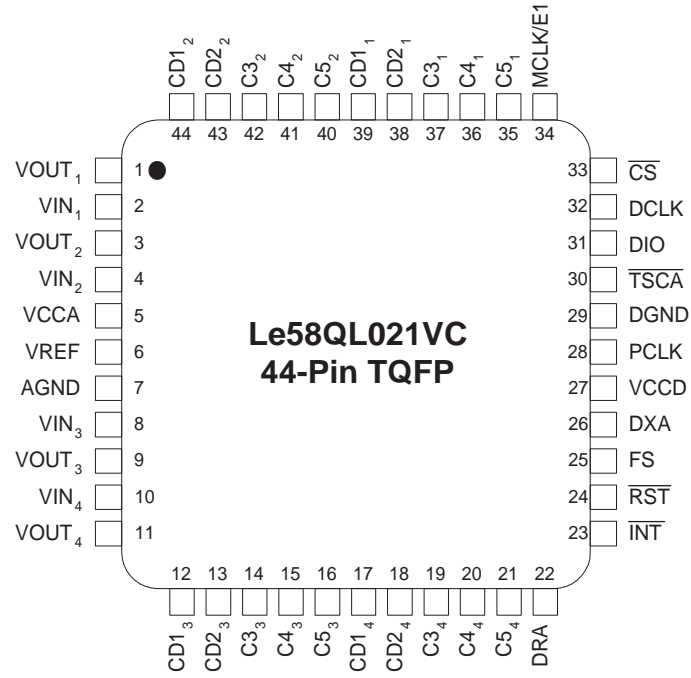

Figure 4. Le58QL021VC 44-Pin PLCC



PIN DESCRIPTIONS

Pin Names	Type	Description
AGND, DGND	Power	Separate analog and digital grounds are provided to allow noise isolation; however, the two grounds are connected inside the part, and the grounds must also be connected together on the circuit board.
CD1 ₁ –CD1 ₄ , CD2 ₁ –CD2 ₄	Inputs/Outputs	<p>Control and Data. CD1 and CD2 are TTL compatible programmable Input or Output (I/O) ports. They can be used to monitor or control the state of the SLIC device or any other device associated with the subscriber line interface. The direction, input or output, is programmed using MPI Command 54/55h. As outputs, CD1 and CD2 can be used to control relays, illuminate LEDs, or perform any other function requiring a latched TTL compatible signal for control. The output state of CD1 and CD2 is written using MPI Command 52h. As inputs, CD1 and CD2 can be processed by the QLSLAC device (if programmed to do so). CD1 can be debounced before it is made available to the system. The debounce time is programmable from 0 to 15 ms in 1 ms increments using MPI Command C8/C9h. CD2 can be filtered using the up/down counter facility and programming the sampling interval using MPI Command E8/E9h.</p> <p>Additionally, CD1 can be demultiplexed into two separate inputs using the E1 demultiplexing function. The E1 demultiplexing function of the QLSLAC device was designed to interface directly to Legerity SLIC devices supporting the ground key function. With the proper Legerity SLIC device and the E1 function of the QLSLAC device enabled, the CD1 bit can be demultiplexed into an Off-Hook/Ring Trip signal and Ground Key signal. In the demultiplex mode, the second bit, Ground Key, takes the place of the CD2 as an input. The demultiplexed bits can be debounced (CD1) or filtered (CD2) as explained previously. A more complete description of CD1, CD2, debouncing, and filtering functions is contained in Operating the QLSLAC Device, on page 26.</p> <p>Once the CD1 and CD2 inputs are processed (Debounced, Filtered and/or Demultiplexed) by the QLSLAC device, the information can be accessed by the system in two ways: 1) on a per channel basis along with C3, C4, and C5 of the specific channel using MPI Command 53h, or 2) by using MPI Command 4D/4Fh, which obtain the CD1 and CD2 bits from all four channels simultaneously. This feature reduces the processor overhead and the time required to retrieve time-critical signals from the line circuits, such as off-hook and ring trip. With this feature, hookswitch status and ring trip information, for example, can be obtained from all four channels of a QLSLAC device with one read command.</p>
C3 ₁ –C3 ₄ , C4 ₁ –C4 ₄ , C5 ₁ –C5 ₄	Inputs/Outputs	<p>Control. C3, C4, and C5 are TTL-compatible programmable Input or Output (I/O) ports. They can be used to monitor or control the state of the SLIC device or any other device associated with subscriber line interface. The direction, input or output, is programmed using MPI Command 54/55h. As outputs, C3, C4, and C5 can be used to control relays, illuminate LEDs, or perform any other function requiring a latched TTL compatible signal for control. The output state of C3, C4, and C5 is written using MPI Command 52h. As inputs, C3, C4, and C5 can be accessed by the system by using MPI Command 53h.</p> <p>The Le58QL021 QLSLAC device contains a single PCM highway and five programmable I/Os per channel (CD1, CD2, C3, C4, and C5) in a 44-pin PLCC or TQFP package. In the Le58QL02 QLSLAC device, the C5₁, C5₂, C5₃, and C5₄ I/Os are eliminated, enabling dual PCM highways and a chopper clock output in a 44-pin PLCC or TQFP package. In the Le58QL031 QLSLAC device, the C3₁–C5₁, C3₂–C5₂, C3₃–C5₃, and C3₄–C5₄ I/Os are eliminated, enabling a single PCM highway and two control and data I/Os (CD1, CD2) per channel in a 32-pin PLCC package.</p>
CHCLK	Output	Chopper Clock. This output provides a 256 kHz or a 292.57 kHz, 50% duty cycle, TTL-compatible clock for use by up to four SLIC devices with built-in switching regulators. The CHCLK frequency is synchronous to the master clock, but the phase relationship to the master clock is random. The chopper clock is not available in all package types.
$\overline{\text{CS}}$	Input	Chip Select. The Chip Select input (active Low) enables the device so that control data can be written to or read from the part. The channels selected for the write or read operation are enabled by writing 1 s to the appropriate bits in the Channel Enable Register of the QLSLAC device prior to the command. See EC1, EC2, EC3, and EC4 of the Command 4A/4Bh Write/Read Channel Enable and Operating Mode Register, on page 43 for more information. If Chip Select is held Low for 16 rising edges of DCLK, a hardware reset is executed when Chip Select returns High.
DCLK	Input	Data Clock. The Data Clock input shifts data into and out of the microprocessor interface of the QLSLAC device. The maximum clock rate is 8.192 MHz.
DIO	Input/Output	Data. Control data is serially written into and read out of the QLSLAC device via the DIO pin, with the most significant bit first. The Data Clock determines the data rate. DIO is high impedance except when data is being transmitted from the QLSLAC device.

Pin Names	Type	Description
DRA, DRB	Inputs	PCM Data Receive A/B. The PCM data for channels 1, 2, 3, and 4 is serially received on either the DRA or DRB port during user-programmed time slots. Data is always received with the most significant bit first. For compressed signals, 1 byte of data for each channel is received every 125 μ s at the PCLK rate. In the Linear state, two consecutive bytes of data for each channel are received every 125 μ s at the PCLK rate. DRB is not available on all package types.
DXA, DXB	Outputs	PCM Data Transmit. The transmit data from channels 1, 2, 3, and 4 is sent serially out on either the DXA or DXB port or both ports during user-programmed time slots. Data is always transmitted with the most significant bit first. The output is available every 125 μ s and the data is shifted out in 8-bit (16-bit in Linear or PCM Signaling state) bursts at the PCLK rate. DXA and DXB are High impedance between time slots, while the device is in the Inactive state with no PCM signaling, or while the Cutoff Transmit Path bit (CTP) is on. DXB is not available on all package types.
FS	Input	Frame Sync. The Frame Sync pulse is an 8 kHz signal that identifies Time Slot 0, Clock Slot 0 of a system's PCM frame. The QLSLAC device references individual time slots with respect to this input, which must be synchronized to PCLK.
$\overline{\text{INT}}$	Output	Interrupt. $\overline{\text{INT}}$ is an active Low output signal which is programmable as either TTL compatible or open drain. The $\overline{\text{INT}}$ output goes Low any time one of the input bits in the Real Time Data register changes state and is not masked. It also goes Low any time new transmit data appears if this interrupt is armed. $\overline{\text{INT}}$ remains Low until the appropriate register is read via the microprocessor interface, or the QLSLAC device receives either a software or hardware reset. The individual CD_{xy} bits in the Real Time Data register can be masked from causing an interrupt by using MPI Command 6C/6Dh. The transmit data interrupt must be armed with a bit in the Operating Conditions register.
MCLK/E1	Input/Output	Master Clock (Input)/Enable CD1 Multiplex (Output). The Master Clock can be a 1.536 MHz, 1.544 MHz, or 2.048 MHz (times 1, 2, or 4) clock for use by the digital signal processor. If the internal clock is derived from the PCM Clock Input (PCLK), this pin can be used as an E1 output to control Legerity SLIC devices having multiplexed hookswitch and ground-key detector outputs.
PCLK	Input	PCM Clock. The PCM clock determines the rate at which PCM data is serially shifted into or out of the PCM ports. PCLK is an integer multiple of the frame sync frequency. The maximum clock frequency is 8.192 MHz and the minimum clock frequency is 128 kHz for dual PCM highway versions and 256 kHz for single PCM highway versions. The minimum clock rate must be doubled if Linear state or PCM signaling is used. PCLK frequencies between 1.03 MHz and 1.53 MHz are not allowed. Optionally, the digital signal processor clock can be derived from PCLK rather than MCLK.
$\overline{\text{RST}}$	Input	Reset. A logic Low signal at this pin resets the QLSLAC device to its default state. The $\overline{\text{RST}}$ pin may be tied to VCCD if it is not needed in the system.
$\overline{\text{TSCA}}, \overline{\text{TSCB}}$	Outputs	Time Slot Control. The Time Slot Control outputs are open drain outputs (requiring pull-up resistors to VCCD) and are normally inactive (High impedance). $\overline{\text{TSCA}}$ or $\overline{\text{TSCB}}$ is active (Low) when PCM data is transmitted on the DXA or DXB pin respectively.
VCCA, VCCD	Power	Analog and digital power supply inputs. VCCA and VCCD are provided to allow for noise isolation and proper power supply decoupling techniques. For best performance, all of the VCC power supply pins should be connected together at the connector of the printed circuit board.
VIN_1 – VIN_4	Inputs	Analog Input. The analog voice band signal is applied to the VIN input of the QLSLAC device. The VIN input is biased at VREF by a large internal resistor. The audio signal is sampled, digitally processed and encoded, and then made available at the TTL-compatible PCM output (DXA or DXB). If the digitizer saturates in the positive or negative direction, VIN is pulled by a reduced resistance toward AGND or VCCD, respectively. VIN_1 is the input for channel 1, VIN_2 is the input for channel 2, VIN_3 is the input for channel 3, and VIN_4 is the input for channel 4.
VOUT_1 – VOUT_4	Outputs	Analog Output. The received digital data at DRA or DRB is processed and converted to an analog signal at the VOUT pin. VOUT_1 is the output from channel 1, VOUT_2 is the output for channel 2, VOUT_3 is the output from channel 3, and VOUT_4 is the output for channel 4. The VOUT voltages are referenced to VREF.
VREF	Output	Analog Voltage Reference. The VREF output is provided in order for an external capacitor to be connected from VREF to ground, filtering noise present on the internal voltage reference. VREF is buffered before it is used by internal circuitry. The voltage on VREF and the output resistance are given in Electrical Characteristics, on page 12 . The leakage current in the capacitor must be low.

ABSOLUTE MAXIMUM RATINGS

Stresses above those listed under "Absolute Maximum Ratings" may cause permanent device failure. Functionality at or above these limits is not implied. Exposure to absolute maximum ratings for extended periods may affect device reliability.

Storage Temperature	$-60^{\circ}\text{C} < T_A < +125^{\circ}\text{C}$
Ambient Temperature, under Bias	$-40^{\circ}\text{C} < T_A < +85^{\circ}\text{C}$
Ambient relative humidity (non condensing)	5 to 95%
V_{CCA} with respect to AGND	-0.4 to + 4.0 V
V_{CCA} with respect to VCCD	± 0.4 V
V_{CCD} with respect to DGND	-0.4 to + 4.0 V
V_{IN} with respect to AGND	-0.4 V to ($V_{CCA} + 0.4$ V)
AGND with respect to DGND	± 50 mV
Digital pins with respect to DGND	-0.4 to 5.5 V or VCCD + 2.37 V, whichever is smaller
Total combined CD1–C5 current per device:	
Source from VCCD	40 mA
Sink into DGND	40 mA
Latch up immunity (any pin)	± 100 mA
Total VCC current if rise rate of VCC > 0.4 V/ μ s	0.5 A

Package Assembly

The green package devices are assembled with enhanced environmental compatible lead (Pb), halogen, and antimony-free materials. The leads possess a matte-tin plating which is compatible with conventional board assembly processes or newer lead-free board assembly processes. The peak soldering temperature should not exceed 245°C during printed circuit board assembly.

Refer to IPC/JEDEC J-Std-020B Table 5-2 for the recommended solder reflow temperature profile.

OPERATING RANGES

Legerity guarantees the performance of this device over commercial (0 to 70°C) and industrial (-40 to 85°C) temperature ranges by conducting electrical characterization over each range and by conducting a production test with single insertion coupled to periodic sampling. These characterization and test procedures comply with section 4.6.2 of Bellcore GR-357-CORE Component Reliability Assurance Requirements for Telecommunications Equipment.

Environmental Ranges

Ambient Temperature	$-40^{\circ}\text{C} < T_A < +85^{\circ}\text{C}$
Ambient Relative Humidity	15 to 85%

Electrical Ranges

Analog Supply V_{CCA}	$+3.3\text{ V} \pm 5\%$ $V_{CCD} \pm 50$ mV
Digital Supply V_{CCD}	$+3.3\text{ V} \pm 5\%$
DGND	0 V
AGND	± 10 mV
CFIL Capacitance: VREF to AGND	$0.1\ \mu\text{F} \pm 20\%$
Digital Pins	DGND to +5.25 V

ELECTRICAL CHARACTERISTICS

Typical values are for TA = 25° C and nominal supply voltages. Minimum and maximum values are over the temperature and supply voltage ranges shown in Operating Ranges, except where noted.

Symbol	Parameter Descriptions	Min	Typ	Max	Unit	Note
V _{IL}	Digital Input Low voltage			0.8	V	
V _{IH}	Digital Input High voltage	2.0				
I _{IL}	Digital Input leakage current				μA	
	0 < V < V _{CCD} Otherwise	-7 -120		+7 +180		
V _{HYS}	Digital Input hysteresis	0.16	0.25	0.34	V	
V _{OL}	Digital Output Low voltage				V	1
	CD1–C5 (I _{OL} = 4 mA)			0.4		
	CD1–C5 (I _{OL} = 8 mA)			0.8		
	TSCA, TSCB (I _{OL} = 14 mA) Other digital outputs (I _{OL} = 2 mA)			0.4 0.4		
V _{OH}	Digital Output High voltage				V	1
	CD1–C5 (I _{OH} = 4 mA)	V _{CCD} - 0.4 V				
	CD1–C5 (I _{OH} = 8 mA)	V _{CCD} - 0.8 V				
	Other digital outputs (I _{OH} = 400 μA)	2.4				
I _{OL}	Digital Output leakage current (H _I Z state)				μA	
	0 < V < V _{CCD} Otherwise	-7 -120		+7 +180		
GIN	Input attenuator gain				V/V	
	DGIN = 0 DGIN = 1		0.6438 1			
V _{IR}	Analog input voltage range (Relative to VREF)				V _{pk}	
	AX = 0 dB, attenuator on (DGIN = 0)		±1.584			
	AX = 6.02 dB, attenuator on (DGIN = 0)		±0.792			
	AX = 0 dB, attenuator off (DGIN = 1) AX = 6.02 dB, attenuator off (DGIN = 1)		±1.02 ±0.51			
V _{IOS}	Offset voltage allowed on VIN	-50		50	mV	
Z _{IN}	Analog input impedance to VREF, 300 to 3400 Hz	600		1400	kΩ	
I _{IP}	Current into analog input for an input voltage of 3.3 V	50		115	μA	2
I _{IN}	Current out of analog input for an input voltage of -0.3 V	50		130		2
Z _{OUT}	V _{OUT} output impedance		1	10	Ω	
CL _{OUT}	Allowable capacitance, V _{OUT} to AGND			500	pF	
I _{OUT}	V _{OUT} output current (F < 3400 Hz)	-4		4	mA _{pk}	3
V _{REF}	VREF output open circuit voltage (leakage < 20 nA)	1.43	1.5	1.57	V	
Z _{REF}	VREF output impedance (F < 3400 Hz)	70		130	kΩ	
V _{OR}	V _{OUT} voltage range (AR = 0 dB) (Relative to VREF) (AR = 6.02 dB)		±1.02 ±0.51		V _{pk}	
V _{OOS}	V _{OUT} offset voltage (AISN off)	-40		40	mV	4
V _{OOSA}	V _{OUT} offset voltage (AISN on)	-80		80		
G _{AISN}	AISN gain - expected gain (input = 0 dBm ₀ , 1014 Hz)				V/V	
	Attenuator on (DGIN = 0) Attenuator off (DGIN = 1)	-0.016 -0.024		0.016 0.024		
PD	Power dissipation				mW	
	All channels active		130	170		
	1 channel active All channels inactive		40 13	80 18		
C _I	Digital Input capacitance			10	pF	
C _O	Digital Output capacitance			10		
PSRR	Power supply rejection ratio (1.02 kHz, 100 mV _{RMS} , either path, GX = GR = 0 dB)	40			dB	

Notes:

1. The CD1, CD2, C3–C5 outputs are resistive for less than a 0.8 V drop. Total current must not exceed absolute maximum ratings.
2. When the digitizer saturates, a resistor of 50 kΩ ±20 kΩ is connected either to AGND or to VCCA as appropriate to discharge the coupling capacitor.
3. When the QLSLAC device is in the Inactive state, the analog output will present either a VREF DC output level through a 15 kΩ resistor (VMODE = 0) or a high impedance (VMODE = 1).
4. If there is an external DC path from VOUT to VIN with a gain of G_{DC} and the AISN has a gain of h_{AISN} , then the output offset will be multiplied by $1 / [1 - (h_{AISN} \cdot G_{DC})]$.
5. Power dissipation in the Inactive state is measured with all digital inputs at $V_{IH} = V_{CCD}$ and $V_{IL} = DGND$ and with no load connected to VOUT1, VOUT2, VOUT3, or VOUT4.

Transmission Characteristics

Table 2. 0 dBm0 Voltage Definitions with Unity Gain in X, R, GX, GR, AX, and AR

Signal at Digital Interface	Transmit (DGIN = 0)	Transmit (DGIN = 1)	Receive	Unit
A-law digital mW or equivalent (0 dBm0)	0.7804	0.5024	0.5024	Vrms
μ-law digital mW or equivalent (0 dBm0)	0.7746	0.4987	0.4987	
±22,827 peak linear coded sine wave	0.7804	0.5024	0.5024	

When relative levels (dBm0) are used in any of the following transmission specifications, the specification holds for any setting of the GX gain from 0 dB to 12 dB, the GR loss from 0 dB to 12 dB, and the input attenuator (GIN) on or off.

Description	Test Conditions	Min	Typ	Max	Unit	Note	
Gain accuracy, D/A or A/D	0 dBm0, 1014 Hz AX = AR = 0 dB 0 to 85° C –40° C	–0.25 –0.30		+0.25 +0.30	dB		
	AX = +6.02 dB and/or AR = –6.02 dB 0 to 85° C –40° C	–0.30 –0.40		+0.30 +0.40			
Gain accuracy digital-to-digital		–0.25		+0.25			
Gain accuracy analog-to-analog		–0.25		+0.25			
Attenuation distortion	300 Hz to 3 kHz	–0.125		+0.125			1
Single frequency distortion				–46			2
Second harmonic distortion, D-A	GR = 0 dB			–55			
Idle channel noise	Analog out	Digital looped back	weighted	–68	dBm0p	3	
			unweighted	–55		3	
	Digital out	Digital input = 0	A-law	–78	dBm0p	3	
		Digital input = 0	μ-law	12	dBm0p	3, 6	
	Analog $V_{IN} = 0$ VAC	A-law	–68	dBm0p	3		
	Analog $V_{IN} = 0$ VAC	μ-law	16	dBm0p	3, 6		
Crosstalk same channel	TX to RX RX to TX	0 dBm0	300 to 3400 Hz	–75	dBm0		
		0 dBm0	300 to 3400 Hz	–75			
Crosstalk between channels	TX or RX to TX TX or RX to RX	0 dBm0			dBm0	4	
			1014 Hz, Average	–76			
			1014 Hz, Average	–78			
End-to-end group delay	B = Z = 0; X = R = 1			678	μs	5	

Notes:

1. See Figure 5 and Figure 6.
2. 0 dBm0 input signal, 300 Hz to 3400 Hz; measurement at any other frequency, 300 Hz to 3400 Hz.
3. No single frequency component in the range above 3800 Hz may exceed a level of –55 dBm0.
4. The weighted average of the crosstalk is defined by the following equation, where $C(f)$ is the crosstalk in dB as a function of frequency, $f_N = 3300$ Hz, $f_1 = 300$ Hz, and the frequency points ($f_j, j = 2..N$) are closely spaced:

$$\text{Average} = 20 \cdot \log \left[\frac{\sum_j \frac{10^{\frac{1}{20} \cdot C(f_j)} + 10^{\frac{1}{20} \cdot C(f_{j-1})}}{2} \cdot \log \left(\frac{f_j}{f_{j-1}} \right)}{\log \left(\frac{f_N}{f_1} \right)} \right]$$

5. The End-to-End Group Delay is the sum of the transmit and receive group delays (both measured using the same time and clock slot).
6. Typical values not tested in production.

Attenuation Distortion

The signal attenuation in either path is nominally independent of the frequency. The deviations from nominal attenuation will stay within the limits shown in [Figure 5](#) and [Figure 6](#). The reference frequency is 1014 Hz and the signal level is -10 dBm0.

Figure 5. Transmit Path Attenuation vs. Frequency

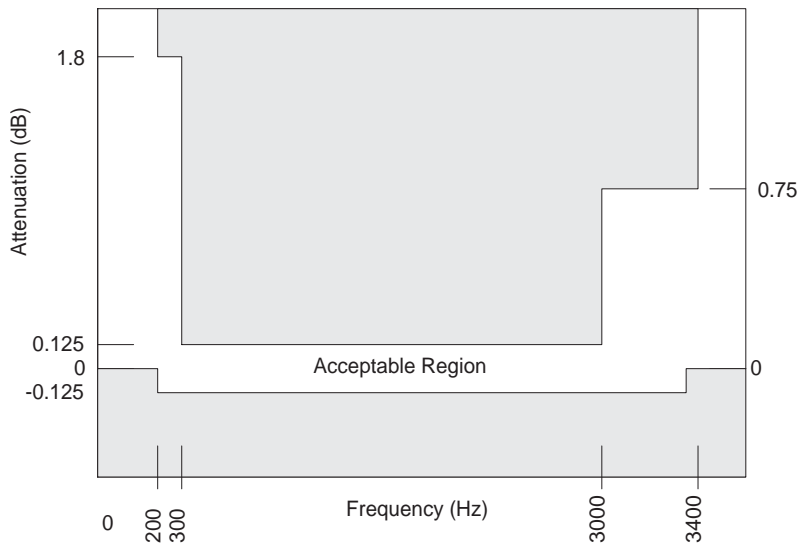
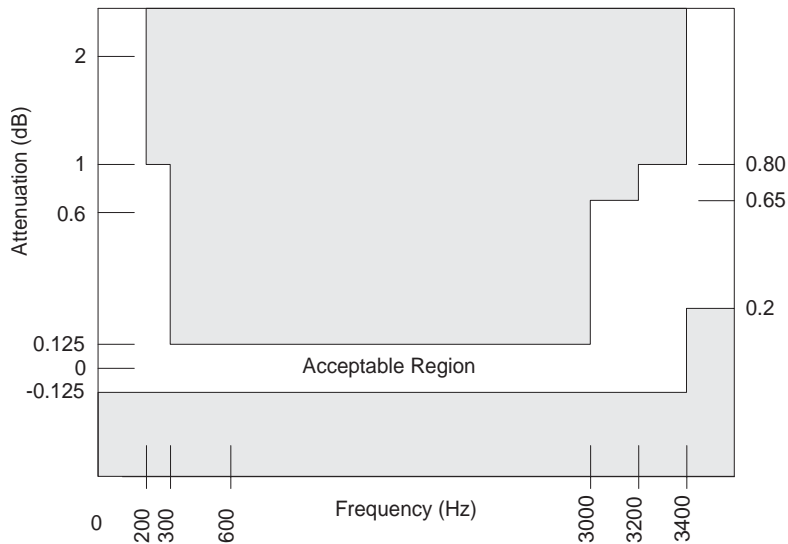
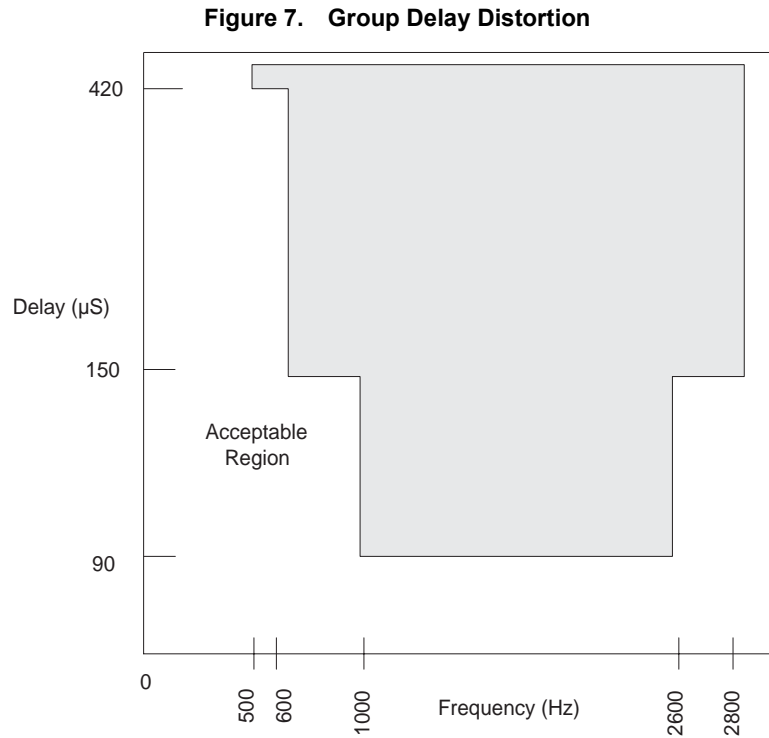

Figure 6. Receive Path Attenuation vs. Frequency



Group Delay Distortion

For either transmission path, the group delay distortion is within the limits shown in [Figure 7](#). The minimum value of the group delay is taken as the reference. The signal level should be 0 dBm0.



Gain Linearity

The gain deviation relative to the gain at -10 dBm0 is within the limits shown in [Figure 8](#) (A-law) and [Figure 9](#) (μ -law) for either transmission path when the input is a sine wave signal of 1014 Hz.

Figure 8. A-law Gain Linearity with Tone Input (Both Paths)

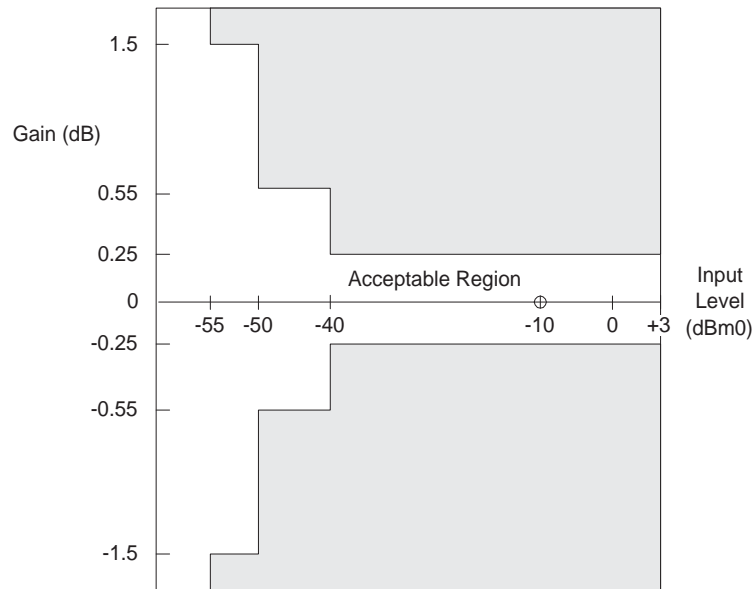
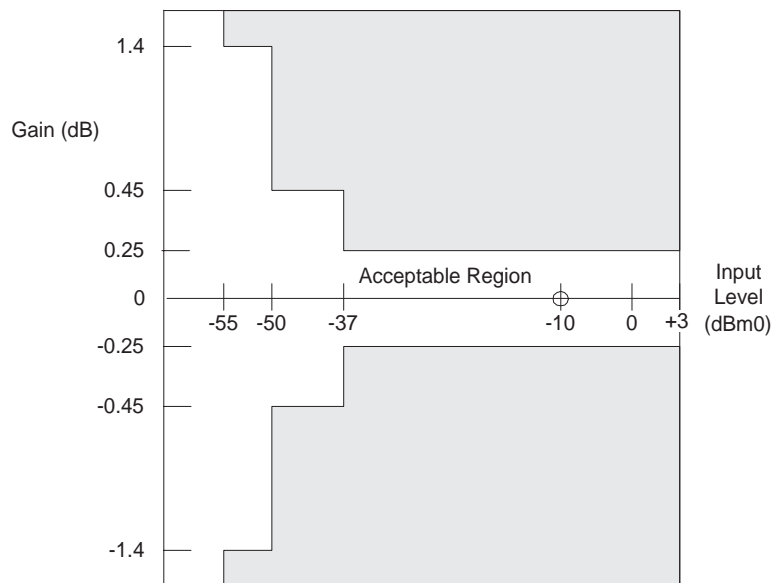

Figure 9. μ -law Gain Linearity with Tone Input (Both Paths)



Total Distortion Including Quantizing Distortion

The signal to total distortion ratio will exceed the limits shown in [Figure 10](#) for either path when the input signal is a sine wave signal of frequency 1014 Hz.

Figure 10. Total Distortion with Tone Input (Both Paths)

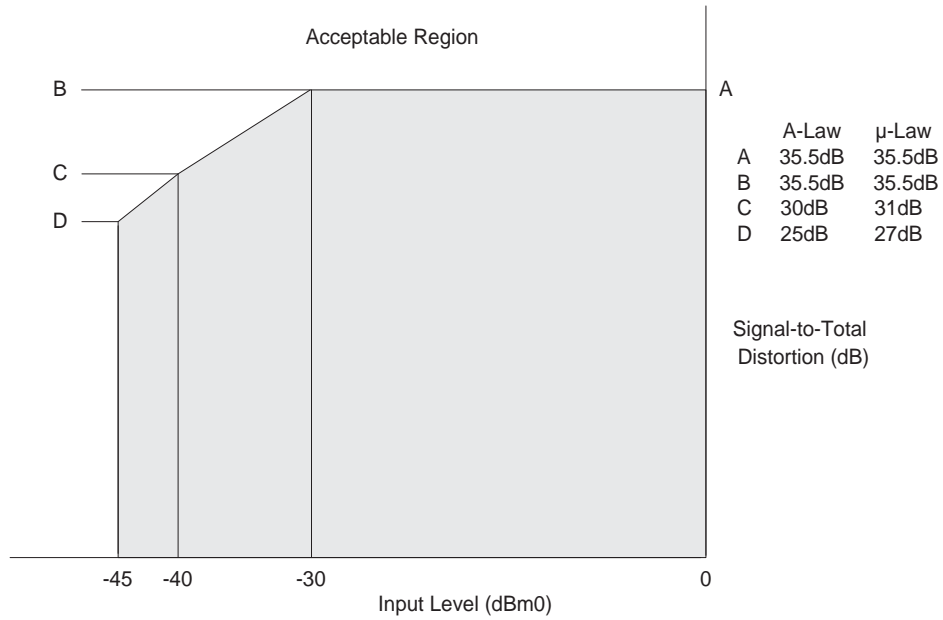

Discrimination Against Out-of-Band Input Signals

When an out-of-band sine wave signal of frequency f , and level A is applied to the analog input, there may be frequency components below 4 kHz at the digital output which are caused by the out-of-band signal. These components are at least the specified dB level below the level of a signal at the same output originating from a 1014 Hz sine wave signal with a level of A dBm0 also applied to the analog input. The minimum specifications are shown in the following table.

Frequency of Out-of-Band Signal	Amplitude of Out-of-Band Signal	Level below A
$16.6 \text{ Hz} < f < 45 \text{ Hz}$	$-25 \text{ dBm0} < A \leq 0 \text{ dBm0}$	18 dB
$45 \text{ Hz} < f < 65 \text{ Hz}$	$-25 \text{ dBm0} < A \leq 0 \text{ dBm0}$	25 dB
$65 \text{ Hz} < f < 100 \text{ Hz}$	$-25 \text{ dBm0} < A \leq 0 \text{ dBm0}$	10 dB
$3400 \text{ Hz} < f < 4600 \text{ Hz}$	$-25 \text{ dBm0} < A \leq 0 \text{ dBm0}$	see Figure 11
$4600 \text{ Hz} < f < 100 \text{ kHz}$	$-25 \text{ dBm0} < A \leq 0 \text{ dBm0}$	32 dB

Figure 11. Discrimination Against Out-of-Band Signals

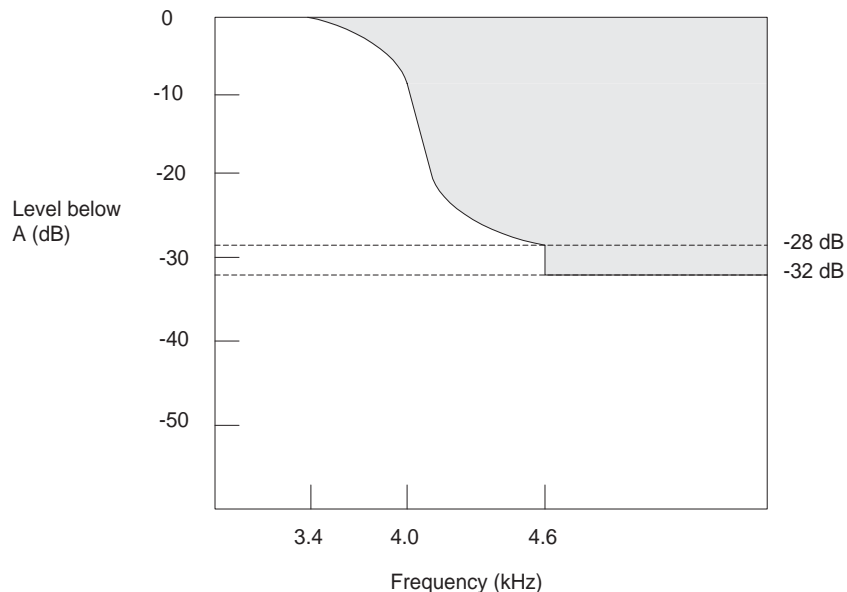

Note:

The attenuation of the waveform below amplitude A , between 3400 Hz and 4600 Hz, is given by the formula:

$$\text{Attenuation (db)} = 14 - 14 \sin\left(\frac{\pi(4000 - f)}{1200}\right)$$

Discrimination Against 12- and 16-kHz Metering Signals

If the QLSLAC device is used in a metering application where 12 kHz or 16 kHz tone bursts are injected onto the telephone line toward the subscriber, a portion of these tones also may appear at the VIN terminal. These out-of-band signals may cause frequency components to appear below 4 kHz at the digital output. For a 12 kHz or 16 kHz tone, the frequency components below 4 kHz are reduced from the input by at least 70 dB. The sum of the peak metering and signal voltages must be within the analog input voltage range.

Spurious Out-of-Band Signals at the Analog Output

With PCM code words representing a sine wave signal in the range of 300 Hz to 3400 Hz at a level of 0 dBm0 applied to the digital input, the level of the spurious out-of-band signals at the analog output is less than the limits shown below.

Frequency	Level
4.6 kHz to 40 kHz	-32 dBm0
40 kHz to 240 kHz	-46 dBm0
240 kHz to 1 MHz	-36 dBm0

With code words representing any sine wave signal in the range 3.4 kHz to 4.0 kHz at a level of 0 dBm0 applied to the digital input, the level of the signals at the analog output are below the limits in [Figure 12](#). The amplitude of the spurious out-of-band signals between 3400 Hz and 4600 Hz is given by the formula:

$$\text{Level} = \left[-14 - 14 \sin\left(\frac{\pi(f - 4000)}{1200}\right) \right] \text{ dBm0}$$

Figure 12. Spurious Out-of-Band Signals

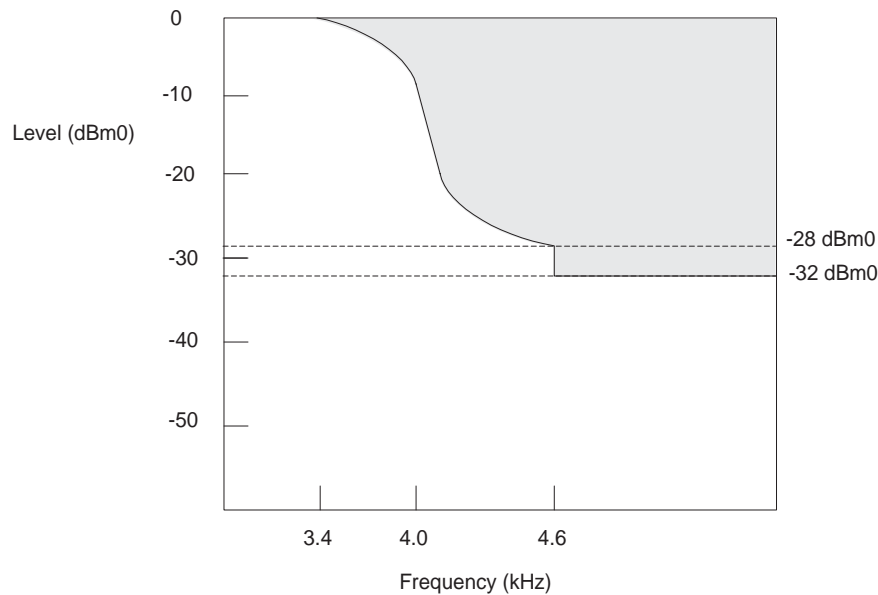

Overload Compression

Figure 13 shows the acceptable region of operation for input signal levels above the reference input power (0 dBm0). The conditions for this figure are:

1. $1.2 \text{ dB} < \text{GX} \leq +12 \text{ dB}$
2. $-12 \text{ dB} \leq \text{GR} < -1.2 \text{ dB}$
3. Digital voice output connected to digital voice input.
4. Measurement analog-to-analog.

Figure 13. Analog-to-Analog Overload Compression

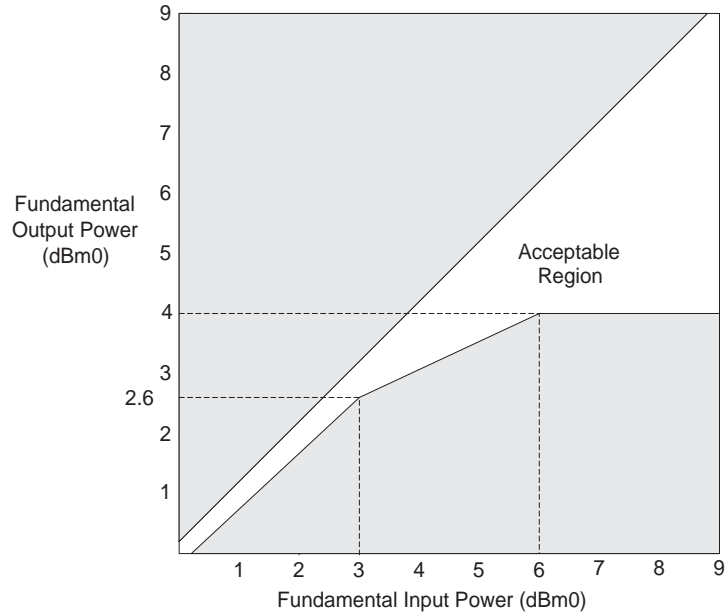

SWITCHING CHARACTERISTICS

The following are the switching characteristics over operating range (unless otherwise noted). Min and max values are valid for all digital outputs with a 115 pF load, except CD1–C5 with a 30 pF load. (See Figure 15 and Figure 16 for the microprocessor interface timing diagrams.)

Microprocessor Interface

No.	Symbol	Parameter	Min	Typ	Max	Unit	Note
1	t_{DCY}	Data clock period	122			ns	
2	t_{DCH}	Data clock HIGH pulse width	48				
3	t_{DCL}	Data clock LOW pulse width	48				
4	t_{DCR}	Rise time of clock			25		
5	t_{DCF}	Fall time of clock			25		
6	t_{ICSS}	Chip select setup time, Input mode	30		$t_{DCY}-10$		
7	t_{ICSH}	Chip select hold time, Input mode	0		$t_{DCH}-20$		
8	t_{ICSL}	Chip select pulse width, Input mode		$8t_{DCY}$			
9	t_{ICSO}	Chip select off time, Input mode	2500				1
10	t_{IDS}	Input data setup time	25				
11	t_{IDH}	Input data hold time	30				
12	t_{OLH}	SLIC device output latch valid			2500		
13	t_{OCSS}	Chip select setup time, Output mode	30		$t_{DCY}-10$		
14	t_{OCSH}	Chip select hold time, Output mode	0		$t_{DCH}-20$		
15	t_{OCSL}	Chip select pulse width, Output mode		$8t_{DCY}$			
16	t_{OCSSO}	Chip select off time, Output mode	2500				1
17	t_{ODD}	Output data turn on delay			50		2
18	t_{ODH}	Output data hold time	3				
19	t_{ODOF}	Output data turn off delay			50		
20	t_{ODC}	Output data valid			50		
21	t_{RST}	Reset pulse width	50			μ s	

PCM Interface

PCLK not to exceed 8.192 MHz.

Pull-up resistors to V_{CCD} of 240 Ω are attached to \overline{TSCA} and \overline{TSCB} . (See Figure 17 and Figure 18 for the PCM interface timing diagrams.)

No.	Symbol	Parameter	Min.	Typ	Max	Unit	Note
22	t_{PCY}	PCM clock period	122			ns	3
23	t_{PCH}	PCM clock HIGH pulse width	48				
24	t_{PCL}	PCM clock LOW pulse width	48				
25	t_{PCF}	Fall time of clock			15		
26	t_{PCR}	Rise time of clock			15		
27	t_{FSS}	FS setup time	25		$t_{PCY}-30$		
28	t_{FSH}	FS hold time	50				
30	t_{TSD}	Delay to \overline{TSC} valid	5		80		4
31	t_{TSO}	Delay to \overline{TSC} off	5		80		4, 5
32	t_{DXD}	PCM data output delay	5		70		
33	t_{DXH}	PCM data output hold time	5		70		
34	t_{DXZ}	PCM data output delay to High-Z	5		70		
35	t_{DRS}	PCM data input setup time	25				
36	t_{DRH}	PCM data input hold time	5				

Master Clock

(See [Figure 19, Master Clock Timing, on page 25.](#))

No.	Symbol	Parameter	Min	Typ	Max	Unit	Notes
37	J_{MCL}	Master clock jitter			50	ns	6
38	t_{MCR}	Rise time of clock			15		
39	t_{MCF}	Fall time of clock			15		
40	t_{MCH}	MCLK HIGH pulse width	48				
41	t_{MCL}	MCLK LOW pulse width	48				

Auxiliary Output Clocks

No.	Symbol	Parameter	Min	Typ	Max	Unit	Notes
42	f_{CHP}	Chopper clock frequency CHP = 0 CHP = 1		256 292.57		kHz	7
42A	DC_{CHP}	Chopper click duty cycle		50		%	7
43	f_{E1}	E1 output frequency (CMODE = EE1 = 1)		4.923		kHz	7
44	t_{E1}	E1 pulse width (CMODE = EE1 = 1)		31.25		μ s	7

Notes:

1. If CFAIL = 1 (Command 55h), GX, GR, Z, B1, X, R, and B2 coefficients must not be written or read without first deactivating all channels or switching them to default coefficients; otherwise, a chip select off time of 25 μ s is required.
2. The first data bit is enabled on the falling edge of \overline{CS} or on the falling edge of DCLK, whichever occurs last.
3. The PCM clock frequency must be an integer multiple of the frame sync frequency. The maximum allowable PCM clock frequency is 8.192 MHz. The actual PCM clock rate is dependent on the number of channels allocated within a frame. The minimum clock frequency is 128 kHz in Companded state and 256 kHz in Linear state, PCM Signaling state, or double PCLK state. The minimum PCM clock rates should be doubled for parts with only one PCM highway in order to allow simultaneous access to all four channels.
4. \overline{TSC} is delayed from FS by a typical value of $N \cdot t_{PCY}$, where N is the value stored in the time/clock-slot register.
5. t_{TSO} is defined as the time at which the output achieves the Open Circuit state.
6. PCLK and MCLK are required to be integer multiples of the frame sync (FS) frequency. Frame sync is expected to be an accurate 8 kHz pulse train. If PCLK or MCLK has jitter, care must be taken to ensure that all setup, hold, and pulse width requirements are met.
7. Phase jumps of 81 nS will be present when the master clock frequency is a multiple of 1.544 MHz.

SWITCHING WAVEFORMS

Figure 14. Input and Output Waveforms for AC Tests

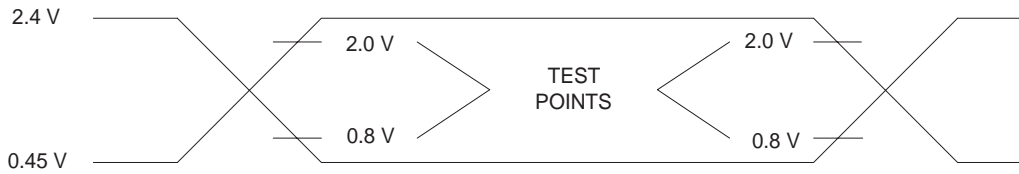

Figure 15. Microprocessor Interface (Input Mode)

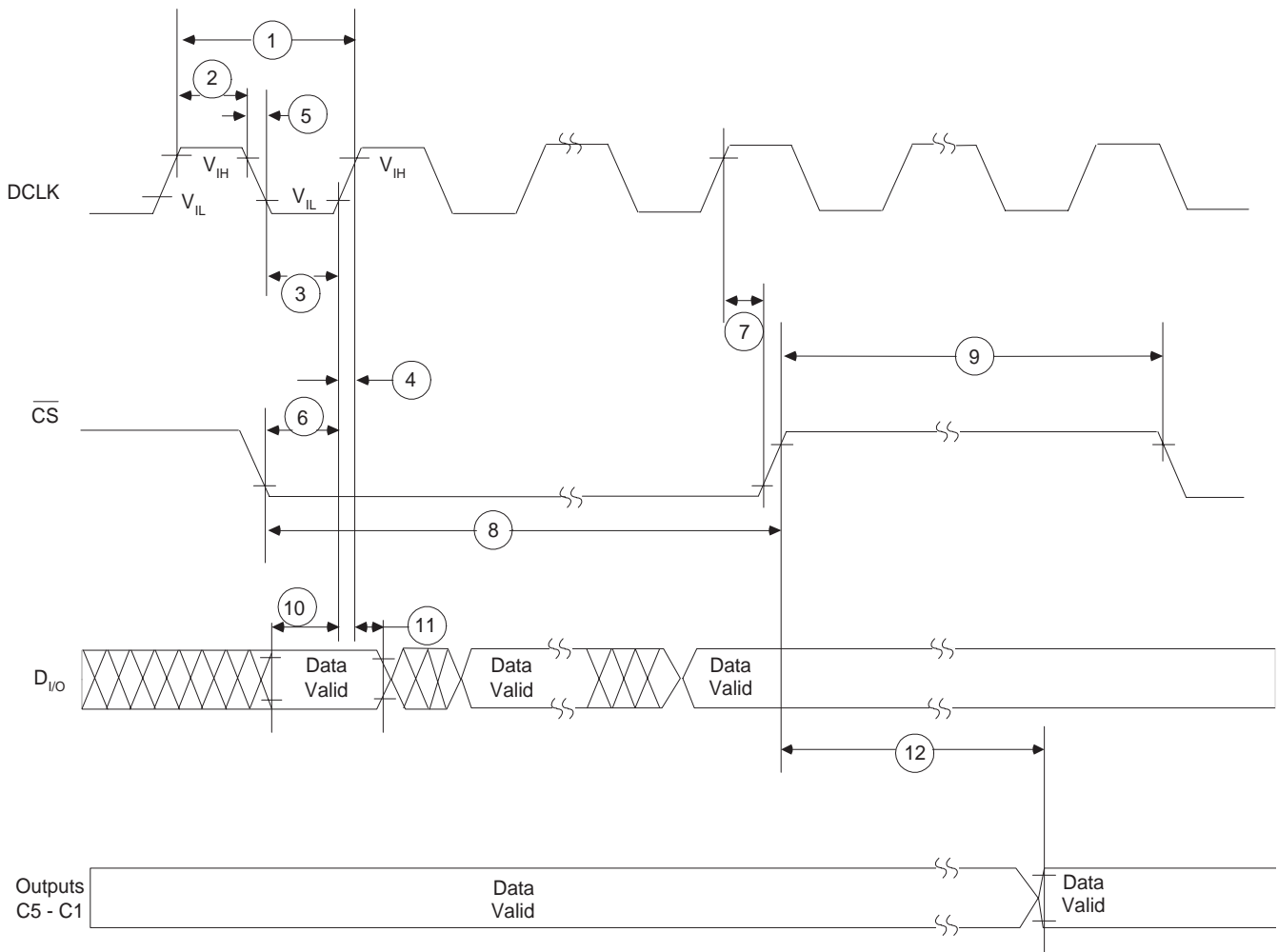

Figure 16. Microprocessor Interface (Output Mode)

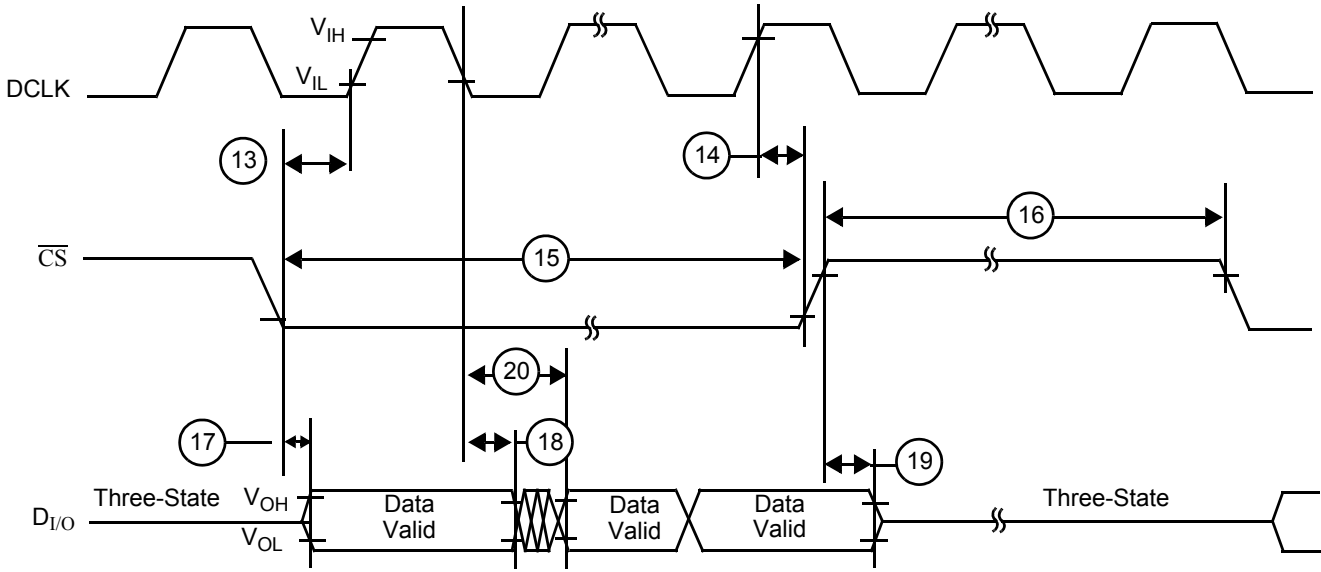

Figure 17. PCM Highway Timing for XE = 0 (Transmit on Negative PCLK Edge)

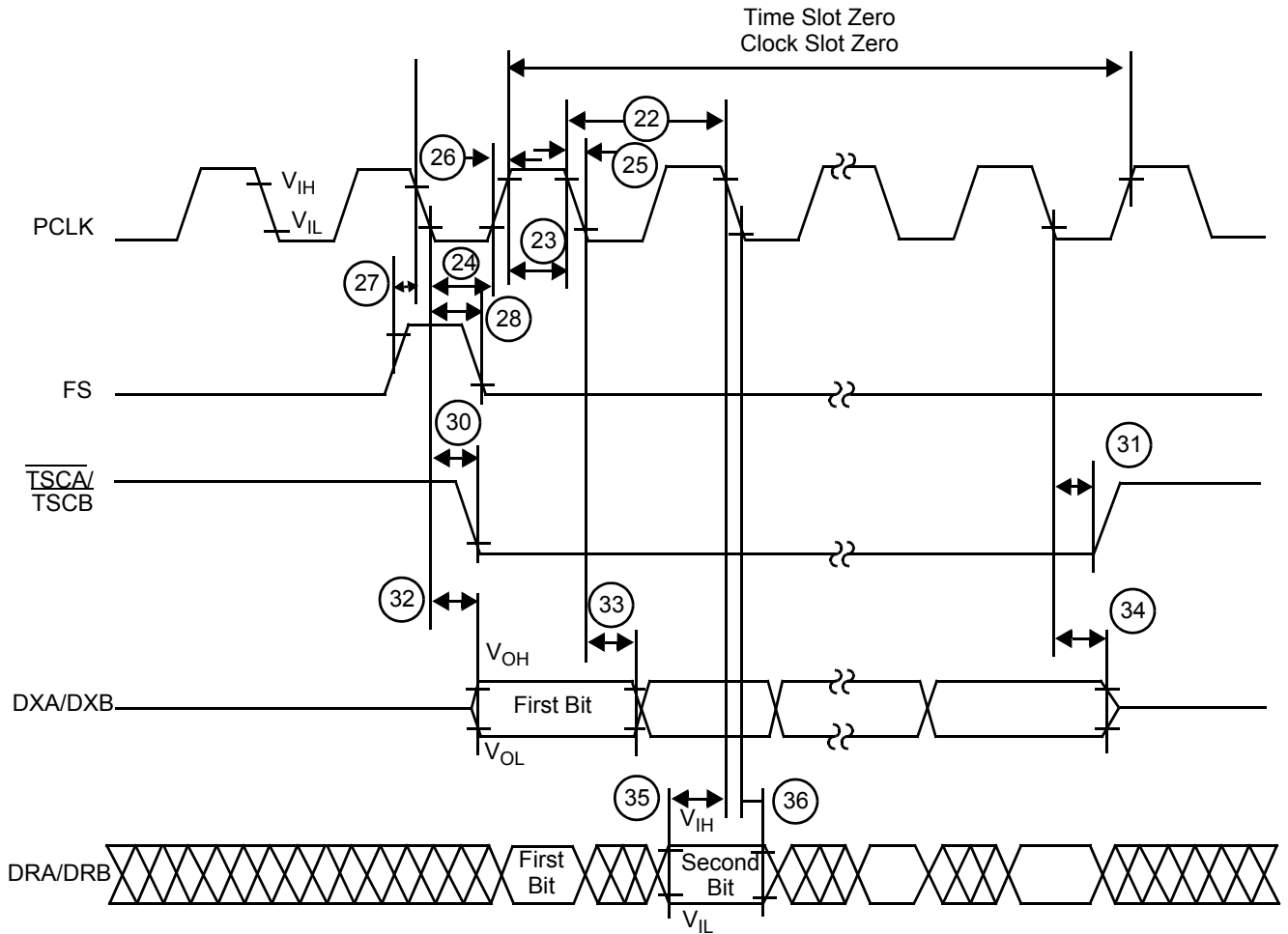

Figure 18. PCM Highway Timing for XE = 1 (Transmit on Positive PCLK Edge)

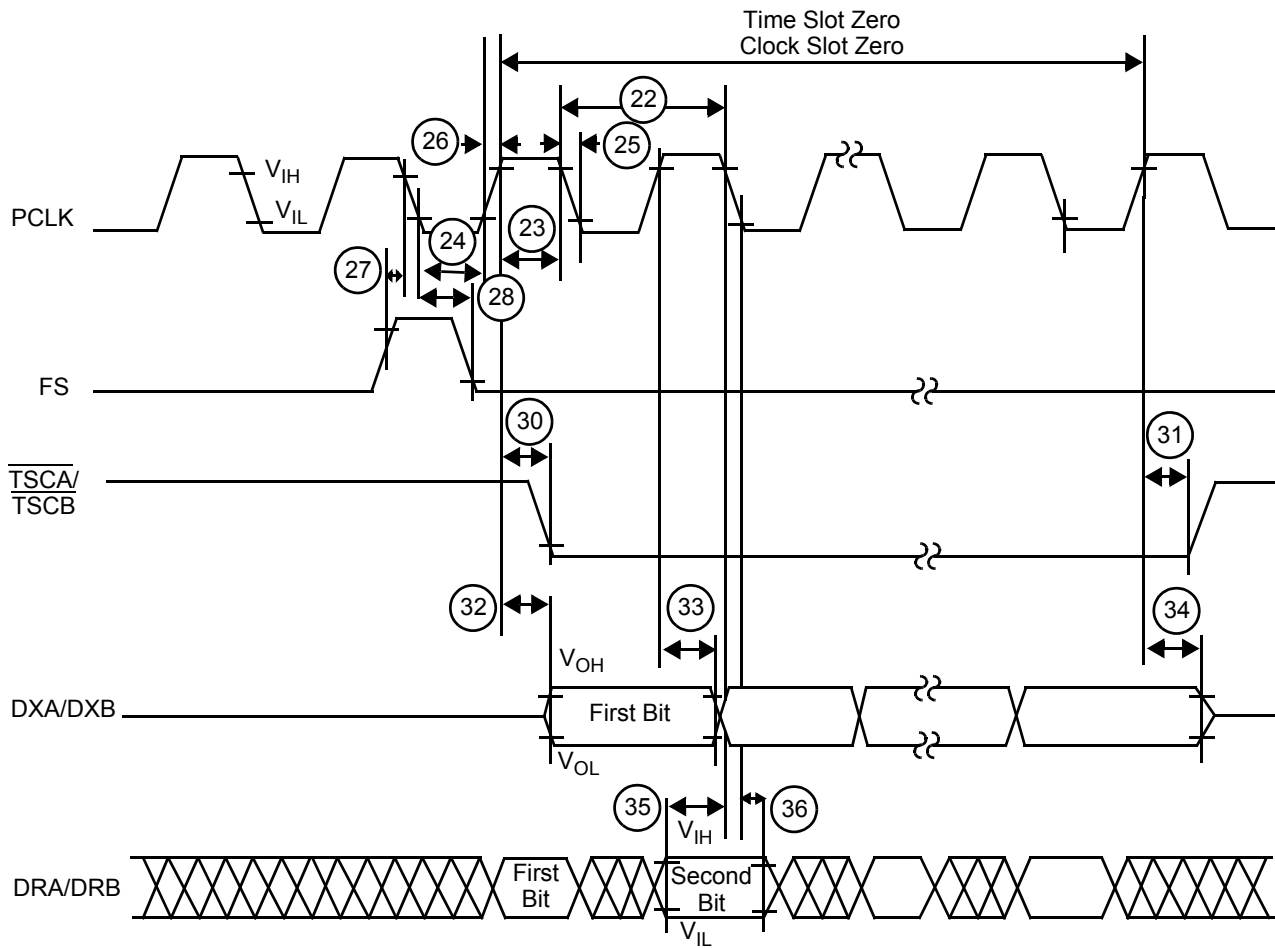
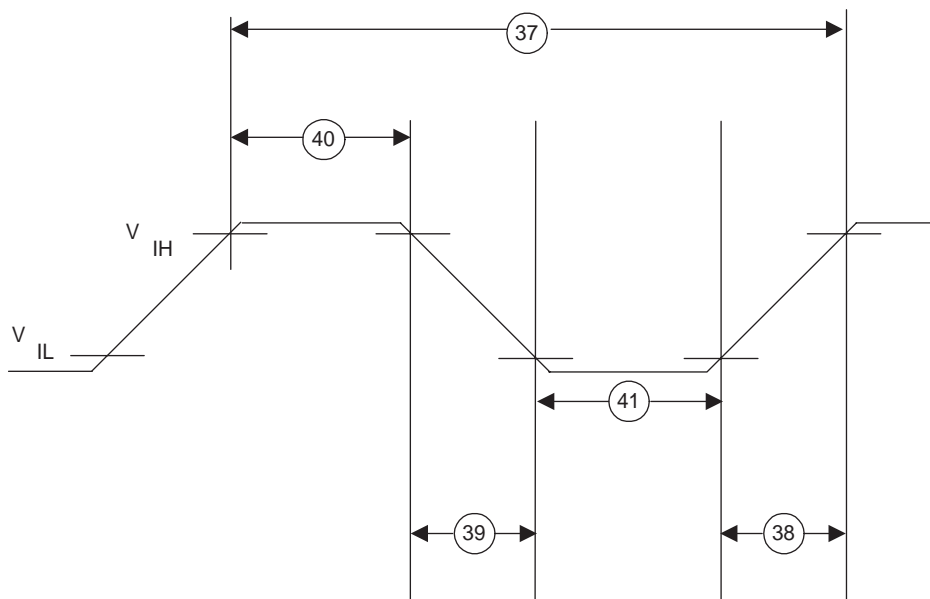

Figure 19. Master Clock Timing



OPERATING THE QLSLAC DEVICE

The following sections describe the operation of the four independent channels of the QLSLAC device. The description is valid for channel 1, 2, 3, or 4; consequently, the channel subscripts have been dropped. For example, VOUT refers to either VOUT1, VOUT2, VOUT3, or VOUT4.

Power-Up Sequence

The recommended QLSLAC device power-up sequence is to apply:

1. Analog and digital ground
2. VCC, signal connections, and Low on $\overline{\text{RST}}$
3. High on $\overline{\text{RST}}$

The software initialization should then include:

1. Wait 1 ms.
2. Select master clock frequency and source (Command 46/47h). This should turn off the CFAIL bit (Command 55h) within 400 μs .
3. Program filter coefficients and other parameters as required.
4. Activate (Command 0Eh).

If the power supply (VCCD) falls below an internal threshold, the device is reset and will require complete reprogramming with the above sequence. A reset may be initiated by connection of a logic Low to the $\overline{\text{RST}}$ pin, or if chip select ($\overline{\text{CS}}$) is held low for 16 rising edges of DCLK, a hardware reset is generated when CS returns high. The $\overline{\text{RST}}$ pin may be tied to VCCD if it is not used in the system.

Channel Enable (EC) Register

A channel enable register has been implemented in the QLSLAC device in order to reduce the effort required to address individual or multiple channels of the QLSLAC device. The register is written using MPI Command 4A/4Bh. Each bit of the register is assigned to one unique channel, bit 0 for channel 1, bit 1 for channel 2, bit 2 for channel 3, and bit 3 for channel 4. The channel or channels are enabled when their corresponding enable bits are High. All enabled channels will receive the data written to the QLSLAC device. This enables a Broadcast mode (all channels enabled) to be implemented simply and efficiently, and multiple channel addressing is accomplished without increasing the number of I/O pins on the device. The Broadcast mode can be further enhanced by providing the ability to select many chips at once; however, care must be taken not to enable more than one chip in the Read state. This can lead to an internal bus contention, in which excess power is dissipated. (Bus contention will not damage the device.)

SLIC Device Control and Data Lines

The QLSLAC device has up to five SLIC device programmable digital input/output pins per channel (CD1–C5). Each of these pins can be programmed as either an input or an output using the I/O Direction register, Command 54/55h (see Figure 21). The output latches can be written with Command 52h; however, only those bits programmed as outputs will actually drive the pins. The inputs can be read with Command 53h. If a pin is programmed as an output, the data read from it will be the contents of the output latch. It is recommended that any of the SLIC device input/output control and data pins, which are to be programmed as outputs, be written to their desired state via Command 52h before writing the data which configures them as outputs with the I/O direction register Command 54/55h. This ensures that when the output is activated, it is already in the correct state, and will prevent unwanted data from being driven from the SLIC device output pins. It is possible to make a SLIC device control output pull up to a non-standard voltage ($V < 5.25\text{ V}$) by connecting a resistor from the output to the desired voltage, sending zero to the output, and using the DIO bit to tri-state the output.

Clock Mode Operation

The QLSLAC device operates with multiple clock signals. The master clock is used for internal timing including operation of the digital signal processing and may be derived from either the MCLK or PCLK source. When MCLK is used as the master clock, it should be synchronous to FS. The allowed frequencies are listed under Command 46/47h.

The PCM clock (PCLK) is used for PCM timing and is an integer multiple of the frame sync frequency. The internal master clock can be optionally derived from the PCLK source by setting the CMODE bit (bit 4, Command 46/47h) to one. In this mode, the MCLK/E1 pin is free to be used as an E1 signal output. Clock mode options and E1 output functions are shown in Figure 20.

Figure 20. Clock Mode Options.

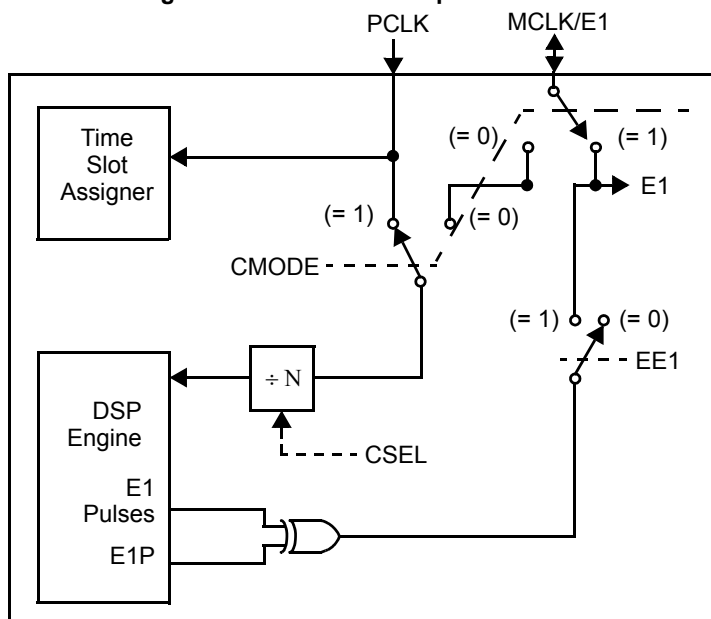

Notes:

1. CMODE = Command 46/47h Bit 4
2. CSEL = Command 46/47h Bits 0–3
3. EE1 = Command C8/C9h Bit 7
4. E1P = Command C8/C9h Bit 6

E1 Multiplex Operation

The QLSLAC device can multiplex input data from the CD1 SLIC device I/O pin into two separate status bits per channel (CD1 and CD1B bits in the SLIC Input/Output register, Command 52/53h, and CDA and CDB bits in the Real Time Data register, Command 4D/4Fh) using the E1 multiplex mode. This multiplex mode provides the means to accommodate dual detect states when connected to an Legerity SLIC device, which also supports ground-key detection in addition to loop detect. Legerity SLIC devices that support ground-key detect use their E1 pin as an input to switch the SLIC device’s single detector (DET) output between internal loop detect or ground-key detect comparators. Using the E1 multiplex mode, a single QLSLAC device can monitor both loop detect and ground-key detect states of all four connected SLIC devices without additional hardware. Although normally used for ground key detect, this multiplex function can also be used for monitoring other signal states.

The E1 multiplex mode is selected by setting the EE1 bit (bit 7, Command C8/C9h) and the CMODE bit (bit 4, Command 46/47h) in the QLSLAC device. The CMODE bit must be selected (CMODE=1) for the master clock to be derived from PCLK so that the MCLK/E1 pin can be used as an output for the E1 signal. The multiplex mode is then turned on by setting the EE1 bit. With the E1 multiplex mode enabled, the QLSLAC device generates the E1 output signal. This signal is a 31.25 μ s (1/32 kHz) duration pulse occurring at a 4.923 kHz (64 kHz/13) rate. If EE1 is reset, MCLK/E1 is programmed as an input and should be connected to ground if it is not connected to a clock source. The polarity of this E1 output is selected by the E1P bit (bit 6, Command C8/C9h) allowing this multiplex mode to accommodate all SLIC devices regardless of their E1 high/low logic definition.

Figure 21 shows the SLIC device Input/Output register, I/O pins, E1 multiplex hardware operation for one QLSLAC device channel. It also shows the operation of the Real Time Register. The QLSLAC device E1 output signal connects directly to the E1 inputs of all four connected SLIC devices and is used by those SLIC devices to select an internal comparator to route to the SLIC device DET output. This E1 signal is also used internally by the QLSLAC device for controlling the multiplex operation and timing.

The CD1 and CD1B bits of the SLIC device Input/Output register are isolated from the CD1 pin by transparent latches. When the E1 pulse is off, the CD1 pin data is routed directly to the CD1 bit of the SLIC device I/O register and changes to the CD1B bit of that register are disabled by its own latch. When E1 pulses on, the CD1 latch holds the last CD1 state in its register. At the same time, the CD1B latch is enabled, which allows CD1 pin data to be routed directly to the CD1B bit. Therefore, during this multiplexing, the CD1 bit always has loop-detect status and the CD1B bit always has ground-key detect status.

This multiplexing state changes almost instantaneously within the QLSLAC device but the SLIC device may require a slightly longer time period to respond to this detect state change before its DET output settles and becomes valid. To accommodate this delay difference, the internal signals within the QLSLAC device are isolated by 15.625 μ s before allowing any change to the CD1 bit and CD1B bit latches. This operation is further described by the E1 multiplex timing diagram in Figure 22. In this timing diagram, the E1 signal represents the actual signal presented to the E1 output pin. The GK Enable pulse allows CD1 pin data to

be routed through the CD1B latch. The LD Enable pulse allows CD1 pin data to be routed through the CD1 latch. The uncertain states of the SLIC device's DET output, and the masked times where that DET data is ignored are shown in this timing diagram. Using this isolation of masked times, the CD1 and CD1B registers are guaranteed to contain accurate representations of the SLIC device detector output.

Figure 21. SLIC Device I/O E1 Multiplex and Real-Time Data Register Operation

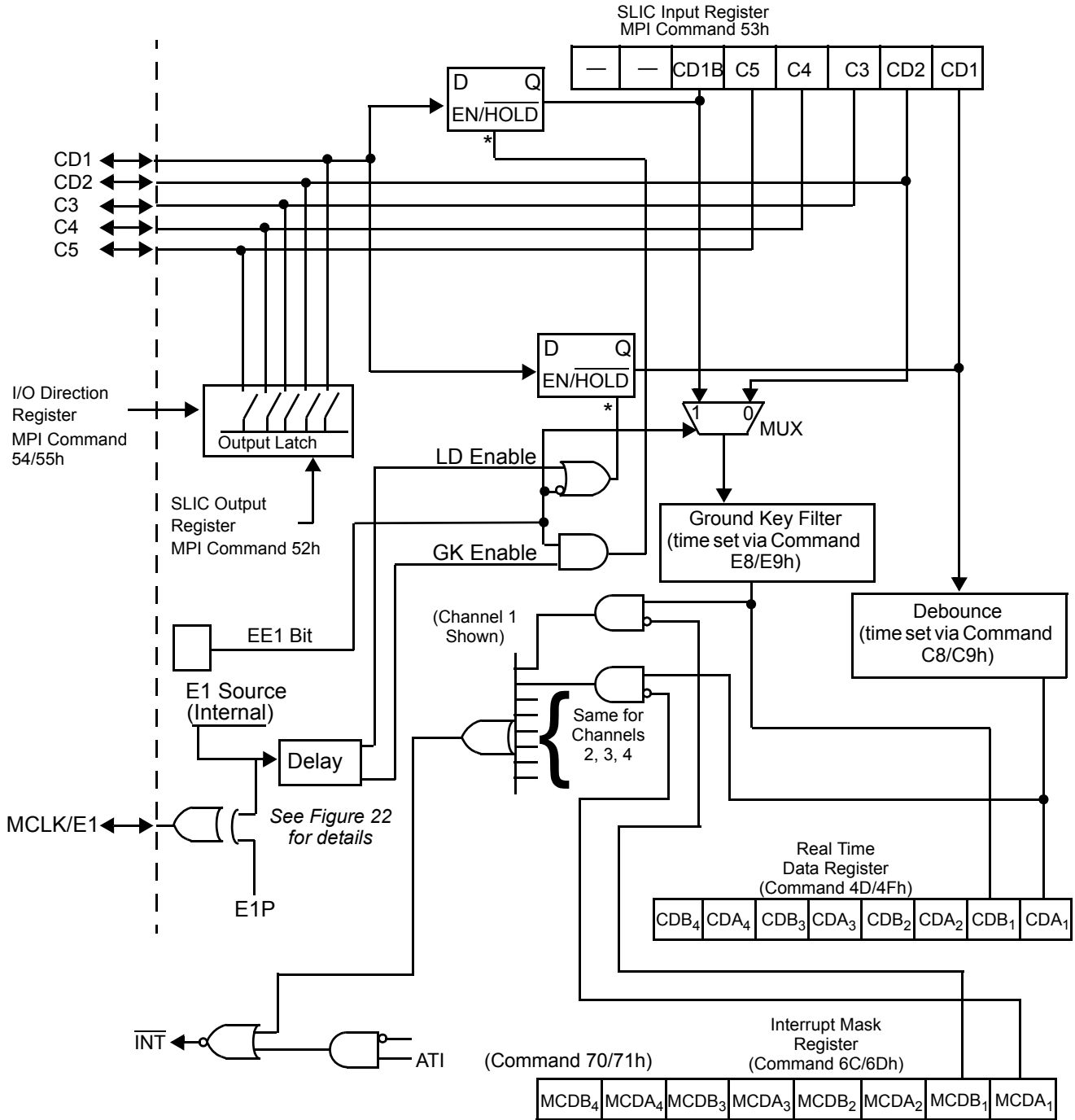

Note:

* Transparent latches: When enable input is high, Q output follows D input. When enable input goes low, Q output is latched at last state.

Figure 22. E1 Multiplex Internal Timing

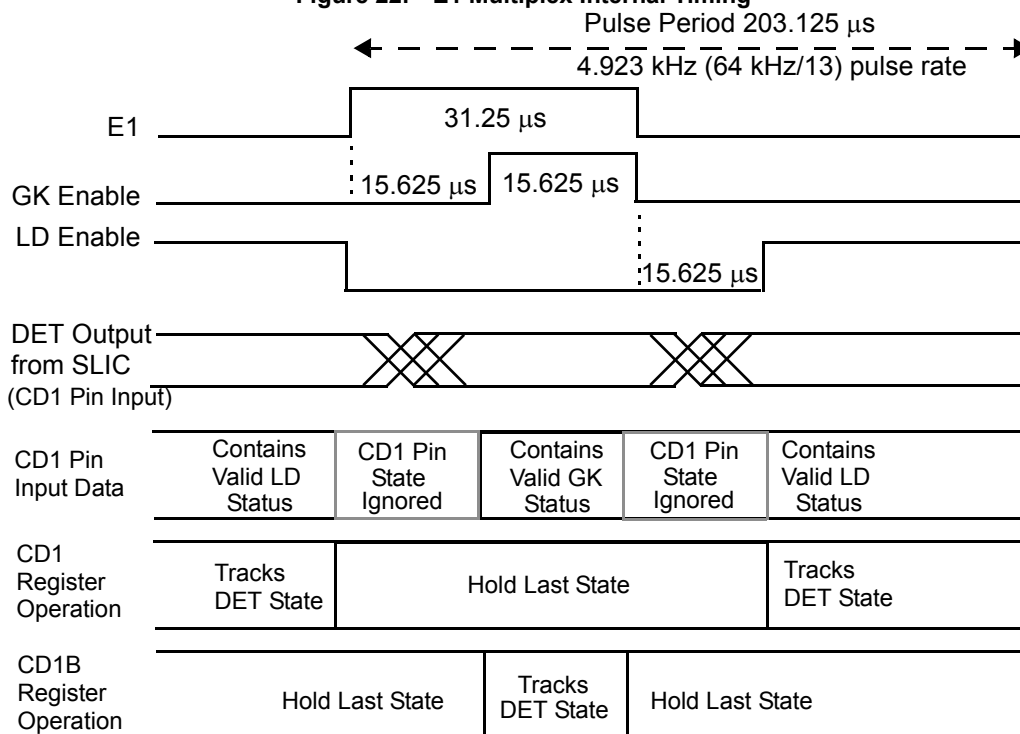

Debounce Filters Operation

Each channel is equipped with two debounce filter circuits to buffer the logic status of the CD1 and CD2/CD1B bits of the SLIC device Input Data Register (Command 53h) before providing filtered bit's outputs to the Real-Time Data Register (Command 4D/4Fh). One filter is used only for the CD1 bit. The other filter acts upon either the CD1B bit if E1 multiplexing is enabled, or on the CD2 bit if the multiplexing is not enabled.

The CD1 bit normally contains SLIC device loop detect status. The CD1 debouncing time is programmable with the Debounce Time Register (Command C8/C9h), and even though each channel has its own filter, the programmed value is common to all four channels. This debounce filter is initially clocked at the frame sync rate of 125 μs, and any occurrence of changing data at this sample rate resets a programmable counter. This programmable counter is clocked at a 1 ms rate, and the programmed count value of 0 to 15 ms, as defined by the Debounce Time Register, must be reached before updating the CDA bit of the Real Time Data register with the CD1 state. Refer to [Figure 23a](#) for this filter's operation.

The ground-key filter (Figure 23b) provides a buffering of the signal, normally ground key detect, which appears in the CD1B bit of the Real Time Data Register. Each channel has its own filter, and each filter's time can be individually programmed. The input to the filter comes from either the CD2 bit of the SLIC device I/O Data Register (Command 53h), when E1 multiplexing is not enabled, or from the CD1B bit of that register when E1 multiplexing is enabled. The feature debounces ground-key signals before passing them to the Real Time Data Register, although signals other than ground-key status can be routed to the CD2 pin and then through the registers.

The ground-key debounce filter operates as a duty-cycle detector and consists of an up/down counter which can range in value between 0 and 6. This six-state counter is clocked by the GK timer at the sampling period of 1–15 ms, as programmed by the value of the four GK bits (GK3, GK2, GK1, GK0) of the Ground-Key Filter Data register (Command E8/E9h). This sampling period clocks the counter, which buffers the CD2/CD1B bit's status before it is valid for presenting to the CDB bit of the Real Time Data Register. When the sampled value of the ground-key (or CD2) input is high, the counter is incremented by each clock pulse. When the sampled value is low, the counter is decremented. Once the counter increments to its maximum value of 6, it sets a latch whose output is routed to the corresponding CDB bit. If the counter decrements to its minimum value of 0, this latch is cleared and the output bit is set to zero. All other times, the latch (and the CDB status) remains in its previous state without change. It therefore takes at least six consecutive GK clocks with the debounce input remaining at the same state to effect an output change. If the GK bit value is set to zero, the buffering is bypassed and the input status is passed directly to CDB.

Figure 23. MPI Real-Time Data Register

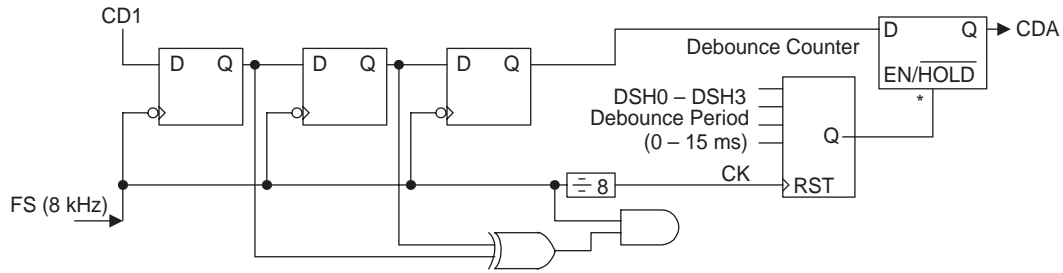

a. Loop Detect Debounce Filter

Notes:

*Transparent latch: Output follows input when EN is high; output holds last state when EN is low.

Debounce counter: Output is high after counting to programmed (DSH) number of 1 ms clocks; counter is reset for CD1 input changes at 125 μ s sample period. DSH0 - DSH3 programmed value is common for all four channels, but debounce counter is separate per channel.

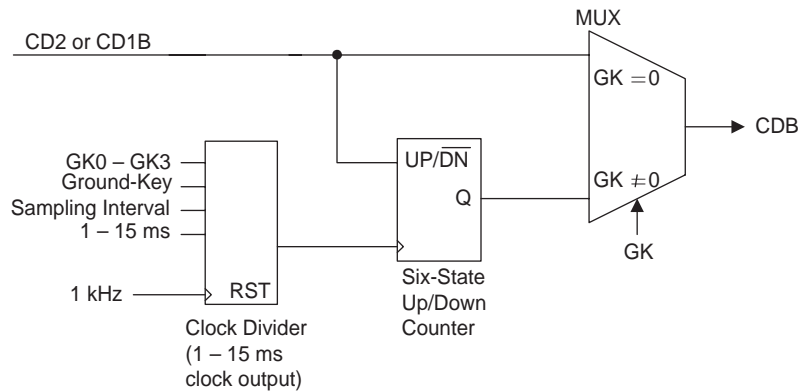

b. Ground-Key Filter

Notes:

Programmed value of GK0 - GK3 determines clock rate (1 - 15 ms) of six-state counter.

If GK value = 0, the counter is bypassed and no buffering occurs.

Six-state up/down counter: Counts up when input is high; counts down when input is low.

Output goes and stays high when maximum count is reached; output goes and stays low when count is down to zero.

Real-Time Data Register Operation

To obtain time-critical data such as off/on-hook and ring trip information from the SLIC device with a minimum of processor time and effort, the QLSLAC device contains an 8-bit Real Time Data register. This register contains CDA and CDB bits from all four channels. The CDA bit for each channel is a debounced version of the CD1 input. The CDA bit is normally used for hook switch. The CDB bit for each channel normally contains the debounced value of the CD2 input bit; however, if the E1 multiplex operation is enabled, the CDB bit will contain the debounced value of the CD1B bit. CD1 and CD2 can be assigned to off-hook, ring trip, ground key signals, or other signals. Frame sync is needed for the debounce and the ground key signals. If Frame sync is not provided, the real-time register will not work. The register is read using MPI Command 4D/4Fh, and may be read at any time regardless of the state of the Channel Enable Register. This allows off/on-hook, ring trip, or ground key information for all four channels to be obtained from the QLSLAC device with one read operation versus one read per channel. If these data bits are not used for supervision information, they can be accessed on an individual channel basis in the same way as C3-C5; however, CD1 and CD1B will not be debounced.

Interrupt

In addition to the Real Time Data register, an interrupt signal has been implemented in the QLSLAC device. The interrupt signal is an active Low output signal which pulls Low whenever the unmasked CD bits change state (Low to High or High to Low); or whenever the transmit PCM data changes on a channel in which the Arm Transmit Interrupt (ATI) bit is on. The interrupt control is shown in Figure 21. The interrupt remains Low until the appropriate register is read. This output can be programmed as TTL or open drain. When an interrupt is generated, all of the unmasked bits in the Real Time Data register latch and remain latched until the interrupt is cleared. The interrupt is cleared by reading the register with Command 4Fh, by writing to the interrupt mask register (Command 6Ch), or by a reset. If any of the inputs to the unmasked bits in the Real Time Data register are different from

the register bits when the interrupt is cleared by reading the register, a new interrupt is immediately generated with the new data latched into the Real Time Data register. For this reason, the interrupt logic in the controller should be level-sensitive rather than edge-sensitive.

Interrupt Mask Register

The Real Time Data register data bits can be masked from causing an interrupt to the processor using the interrupt mask register. The mask register can be written or read via the MPI Command 6C/6Dh.

Active State

Each channel of the QLSLAC device can operate in either the Active (Operational) or Inactive (Standby) state. In the Active state, individual channels of the QLSLAC device can transmit and receive PCM or linear data and analog information. The Active state is required when a telephone call is in progress. The activate command (MPI Command 0Eh), puts the selected channel(s) into this state (see channel enable register). Bringing a channel of the QLSLAC device into the Active state is only possible through the MPI.

Inactive State

All channels of the QLSLAC device are forced into the Inactive (Standby) state by a power-up or hardware reset. Individual channels can be programmed into this state by the deactivate command (Command 00h) or by the software reset command (Command 02h). Power is disconnected from all nonessential circuitry while the MPI remains active to receive commands. The analog output is tied to VREF through a resistor whose value depends on the VMODE bit. All circuits that contain programmed information retain their data in the Inactive state.

Chopper Clock

On the Le58QL02JC there is a chopper clock output to drive the switching regulator on some Legerity SLIC devices. The clock frequency is selectable as 256 or 292.57 kHz by the CHP bit (Command 46/47h). The duty cycle is given in the Switching Characteristics section. The chopper output must be turned on with the ECH bit (Command C8/C9h).

Reset States

The QLSLAC device can be reset by application of power, by an active Low on the hardware Reset pin ($\overline{\text{RST}}$), by a hardware reset command, or by $\overline{\text{CS}}$ Low for 16 or more rising edges of DCLK. This resets the QLSLAC device to the following state:

1. A-law companding is selected.
2. Default B, X, R, and Z filter values from ROM are selected and the AISN is set to zero.
3. Default digital gain blocks (GX, GR) from ROM are selected. The analog gains, AX and AR, are set to 0 dB and the input attenuator is turned on (DGIN = 0).
4. The previously programmed B, Z, X, R, GX, and GR filters in RAM are unchanged.
5. SLIC device I/Os (CD1–C5) are set to the Input state.
6. All of the test states in the Operating Conditions register are turned off (0's).
7. All four channels are in the Inactive (standby) state.
8. Transmit time slots and receive time slots are set to 0, 1, 2, and 3 for channels 1, 2, 3, and 4, respectively. The clock slots are set to 0, with transmit on the negative edge.
9. DXA port is selected for all channels.
10. DRA port is selected for all channels.
11. The master clock frequency selected is 8.192 MHz and is programmed to come from PCLK.
12. All four channels are selected in the Channel Enable register.
13. Any pending interrupts are cleared, all interrupts are masked, and the Interrupt Output state is set to open drain.
14. The supervision debounce time is set to 8 ms.
15. The chopper clock frequency is set to 256 kHz but the chopper clock is turned off.
16. The E1 Multiplex state is turned off (E1 is Hi-Z) and the polarity is set for high going pulses.
17. No signalling on the PCM highway.

SIGNAL PROCESSING

Overview of Digital Filters

Several of the blocks in the signal processing section are user programmable. These allow the user to optimize the performance of the QLSLAC device for the system. Figure 24 shows the QLSLAC device signal processing and indicates the programmable blocks.

The advantages of digital filters are:

- High reliability
- No drift with time or temperature
- Unit-to-unit repeatability
- Superior transmission performance
- Flexibility
- Maximum possible bandwidth for V.90 modems

Figure 24. QLSLAC Device Transmission Block Diagram

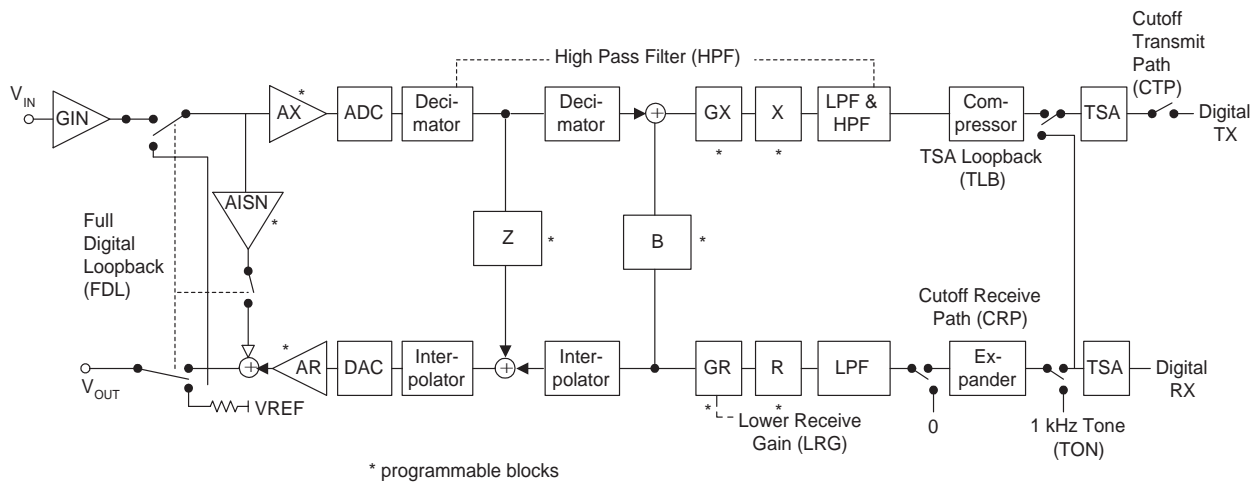

Two-Wire Impedance Matching

Two feedback paths on the QLSLAC device synthesize the two-wire input impedance of the SLIC device by providing a programmable feedback path from V_{IN} to V_{OUT} . The Analog Impedance Scaling Network (AISN) is a programmable analog gain of $-0.9375 \cdot G_{IN}$ to $+0.9375 \cdot G_{IN}$ from V_{IN} to V_{OUT} . (See G_{IN} in [Electrical Characteristics, on page 12.](#)) The Z filter is a programmable digital filter providing an additional path and programming flexibility over the AISN in modifying the transfer function from V_{IN} to V_{OUT} . Together, the AISN and the Z-Filter enable the user to synthesize virtually all required SLIC device input impedances.

Frequency Response Correction and Equalization

The QLSLAC device contains programmable filters in the receive (R) and transmit (X) directions that may be programmed for line equalization and to correct any attenuation distortion caused by the Z filter.

Transhybrid Balancing

The QLSLAC device's programmable B filter is used to adjust transhybrid balance. The filter has a single pole IIR section (BIIR) and an eight-tap FIR section (BFIR), both operating at 16 kHz. (See commands 86/87h and 96/97h.)

Gain Adjustment

The QLSLAC device's transmit path has three programmable gain blocks. Gain block GIN is an attenuator with a gain of GIN (see [Electrical Characteristics, on page 12](#) for the value). Gain block AX is an analog gain of 0 dB or 6.02 dB (unity gain or gain of 2.0), located immediately before the A/D converter. GX is a digital gain block that is programmable from 0 dB to +12 dB, with a worst-case step size of 0.1 dB for gain settings below +10 dB, and a worst-case step size of 0.3 dB for gain settings above +10 dB. The filters provide a net gain in the range of 0 dB to 18 dB.

The QLSLAC device receive path has two programmable loss blocks. GR is a digital loss block that is programmable from 0 dB to 12 dB, with a worst-case step size of 0.1 dB. Loss block AR is an analog loss of 0 dB or 6.02 dB (unity gain or gain of 0.5), located immediately after the D/A converter. This provides a net loss in the range of 0 dB to 18 dB.

An additional 6 dB attenuation is provided as part of GR, which can be inserted by setting the LRG bit of Command 70/71h. This allows writing of a single bit to introduce 6 dB of attenuation into the receive path without having to reprogram GR. This 6 dB loss is implemented as part of GR and the total receive path attenuation must remain in the specified 0 to -12 dB range. If the LRG bit is set, the programmed value of GR must not introduce more than an additional 6 dB attenuation.

Transmit Signal Processing

In the transmit path (A/D), the analog input signal (VIN) is A/D converted, filtered, companded (for A-law or μ -law), and made available to the PCM highway in A-law, μ -law, or linear form. If linear form is selected, the 16-bit data will be transmitted in two consecutive time slots starting at the programmed time slot. The signal processor contains an ALU, RAM, ROM, and control logic to implement the filter sections. The B, X, and GX blocks are user-programmable digital filter sections with coefficients stored in the coefficient RAM, while AX is an analog amplifier that can be programmed for 0 dB or 6.02 dB gain. The B, X, and GX filters can also be operated from an alternate set of default coefficients stored in ROM (Command 60/61h).

The decimator reduces the high input sampling rate to 16 kHz for input to the B, GX, and X filters. The X filter is a six-tap FIR section which is part of the frequency response correction network. The B filter operates on samples from the receive signal path in order to provide transhybrid balancing in the loop. The high-pass filter rejects low frequencies such as 50 Hz or 60 Hz, and may be disabled.

Transmit PCM Interface

The transmit PCM interface transmits a 16-bit linear code (when programmed) or an 8-bit compressed code from the digital A-law/ μ -law compressor. Transmit logic controls the transmission of data onto the PCM highway through output port selection and time/clock slot control circuitry. The linear data requires two consecutive time slots, while a single time slot is required for A-law/ μ -law data.

In the PCM Signaling state (SMODE = 1), the transmit time slot following the A-law or μ -law data is used for signaling information. The two time slots form a single 16-bit data block.

The frame sync (FS) pulse identifies time slot 0 of the transmit frame and all channels (time slots) are referenced to it. The logic contains user-programmable Transmit Time Slot and Transmit Clock Slot registers.

The Time Slot register is 7 bits wide and allows up to 128 8-bit channels (using a PCLK of 8.192 MHz) in each frame. This feature allows any clock frequency between 128 kHz and 8.192 MHz (2 to 128 channels) in a system. The data is transmitted in bytes, with the most significant bit first.

The Clock Slot register is 3 bits wide and may be programmed to offset the time slot assignment by 0 to 7 PCLK periods to eliminate any clock skew in the system. An exception occurs when division of the PCLK frequency by 64 kHz produces a nonzero remainder, R, and when the transmit clock slot is greater than R. In that case, the R-bit fractional time slot after the last full time slot in the frame will contain random information and will have the TSC output turned on. For example, if the PCLK frequency is 1.544 MHz (R = 1) and the transmit clock slot is greater than 1, the 1-bit fractional time slot after the last full time slot in the frame will contain random information, and the TSC output will remain active during the fractional time slot. In such cases, problems can be avoided by not using the last time slot.

The PCM data may be user programmed for output onto either the DXA or DXB port or both ports simultaneously. Correspondingly, either TSCA or TSCB or both are Low during transmission.

The DXA/DXB and $\overline{\text{TSCA}}/\overline{\text{TSCB}}$ outputs can be programmed to change either on the negative or positive edge of PCLK.

Transmit data can also be read through the microprocessor interface using Command CDh.

Receive Signal Processing

In the receive path (D/A), the digital signal is expanded (for A-law or μ -law), filtered, converted to analog, and passed to the VOUT pin. The signal processor contains an ALU, RAM, ROM, and Control logic to implement the filter sections. The Z, R, and GR blocks are user-programmable filter sections with their coefficients stored in the coefficient RAM, while AR is an analog amplifier which can be programmed for a 0 dB or 6.02 dB loss. The Z, R, and GR filters can also be operated from an alternate set of default coefficients stored in ROM (Command 60/61h).

The low-pass filter band limits the signal. The R filter is composed of a six-tap FIR section operating at a 16 kHz sampling rate and a one-tap IIR section operating at 8 kHz. It is part of the frequency response correction network. The Analog Impedance Scaling Network (AISN) is a user-programmable gain block providing feedback from VIN to VOUT to emulate different SLIC device input impedances from a single external SLIC device impedance. The Z filter provides feedback from the transmit signal path to the receive path and is used to modify the effective input impedance to the system. The interpolator increases the sampling rate prior to D/A conversion.

Receive PCM Interface

The receive PCM interface logic controls the reception of data bytes from the PCM highway, transfers the data to the A-law/ μ -law expansion logic for compressed signals, and then passes the data to the receive path of the signal processor. If the data received from the PCM highway is programmed for linear code, the A-law/ μ -law expansion logic is bypassed and the data is presented to the receive path of the signal processor directly. The linear data requires two consecutive time slots, while the A-law or μ -law data requires a single time slot.

The frame sync (FS) pulse identifies time slot 0 of the receive frame, and all channels (time slots) are referenced to it. The logic contains user-programmable Receive Time Slot and Receive Clock Slot registers. The Time Slot register is 7 bits wide and allows up to 128 8-bit channels (using a PCLK of 8.192 MHz) in each frame. This feature allows any clock frequency between 128 kHz and 8.192 MHz (2 to 128 channels) in a system.

The Clock Slot register is 3 bits wide and can be programmed to offset the time slot assignment by 0 to 7 PCLK periods to eliminate any clock skews in the system. An exception occurs when division of the PCLK frequency by 64 kHz produces a nonzero remainder (R), and when the receive clock slot is greater than R. In that case, the last full receive time slot in the frame is not usable. If the PCLK frequency is 1.544 MHz (R=1), the receive clock slot can be only 0 or 1 if the last time slot is to be used. The PCM data can be programmed for input from the DRA or DRB port.

Analog Impedance Scaling Network (AISN)

The AISN is in the QLSLAC device to scale the value of the external SLIC device impedance. Scaling this external impedance with the AISN (along with the Z filter) allows matching of many different line conditions using a single impedance value. Line cards can meet many different specifications without any hardware changes.

The AISN is a programmable transfer function connected from VIN to VOUT of each QLSLAC device channel. The AISN transfer function can be used to alter the input impedance of the SLIC device to a new value (Z_{IN}) given by:

$$Z_{IN} = Z_{SL} \cdot (1 - G_{44} \cdot h_{AISN}) / (1 - G_{440} \cdot h_{AISN})$$

where G_{440} is the SLIC device echo gain into an open circuit, G_{44} is the SLIC device echo gain into a short circuit, and Z_{SL} is the SLIC device input impedance without the QLSLAC device.

The gain can be varied from $-0.9375 \cdot G_{IN}$ to $+0.9375 \cdot G_{IN}$ in 31 steps of $0.0625 \cdot G_{IN}$. The AISN gain is determined by the following equation:

$$h_{AISN} = 0.0625 \cdot G_{IN} \left[\left(\sum_{i=0}^4 AISN_i \cdot 2^i \right) - 16 \right]$$

where each $AISN_i = 0$ or 1

There are two special cases to the formula for h_{AISN} : 1) a value of $AISN = 00000$ specifies a gain of 0 (or cutoff), and 2) a value of $AISN = 10000$ is a special case where the AISN circuitry is disabled and VOUT is connected internally to VIN after the input attenuator with a gain of 0 dB. This allows a Full Digital Loopback state where an input digital PCM signal is completely processed through the receive section, looped back, processed through the transmit section, and output as digital PCM data. During this test, the VIN input is ignored and the VOUT output is connected to VREF.

Speech Coding

The A/D and D/A conversion follows either the A-law or the μ -law standard as defined in ITU-T Recommendation G.711. A-law or μ -law operation is programmed using MPI Command 60/61h. Alternate bit inversion is performed as part of the A-law coding. The QLSLAC device provides linear code as an option on both the transmit and receive sides of the device. Linear code is selected using MPI Command 60/61h. Two successive time slots are required for linear code operation. The linear code is a 16-bit two's-complement number which appears sign bit first on the PCM highway. Linear code occupies two time slots.

Signaling on the PCM Highway

If the SMODE bit is set in the Configuration register (Command 46/47h), each data point occupies two consecutive time slots. The first time slot contains A-law or μ -law data and the second time slot contains the following information:

- Bit 7: Debounced CD1 bit (usually hook switch)
- Bit 6: CD2 bit or CD1B bit
- Bits 5–3: Reserved
- Bit 2: CFAIL
- Bits 1–0: Reserved

Bit 7 of the signaling byte appears immediately after bit 0 of the data byte. A-law or μ -law Companded state must be specified in order to put signaling information on the PCM highway. The signaling time slot remains active, even when the channel is inactive.

Robbed-Bit Signaling Compatibility

The QLSLAC device supports robbed bit signaling compatibility. Robbed bit signaling allows periodic use of the least significant bit (LSB) of the receive path PCM data to be used to carry signaling information. In this scheme, separate circuitry within the line card or system intercepts this bit out of the PCM data stream and uses this bit to control signaling functions within the system. The QLSLAC device does not perform any processing of any of the robbed bits during this operation; it simply allows for the robbed bit presence by performing the LSB substitution.

If the RBE bit is set in the Channel Enable and Operating Mode register (Command 4A/4Bh), then the robbed-bit signaling compatibility mode is enabled. Robbed-bit signaling is only available in the μ -law companding mode of the device. Also, only the receive (digital-to-analog) path is involved. There is no change of operation to the transmit path and PCM data coming out of the QLSLAC device will always contain complete PCM byte data for each time slot, regardless of robbed-bit signaling selection.

In the absence of actual PCM data for the affected time slots, there is an uncertainty of the legitimate value of this bit to accurately reconstruct the analog signal. This bit can always be assumed to be a 1 or 0; hence, the reconstructed signal is correct half the time. However, the other half of the time, there is an unacceptable reconstruction error of a significance equal to the value weighting of the LSB. To reduce this error and provide compatibility with the robbed bit signaling scheme, when in the robbed-bit signaling mode, the QLSLAC device ignores the LSB of each received PCM byte and replaces its value in the expander with a value of half the LSB's weight. This then guarantees the reconstruction is in error by only half this LSB weight. In the expander, the eight bits of the companded PCM byte are expanded into linear PCM data of several more bits within the internal signal processing path of the device. Therefore, accuracy is not limited to the weight of the LSB, and a weight of half this value is realizable.

When this robbed-bit mode is selected, not every frame contains bits for signaling, and therefore not every byte requires its LSB substituted with the half-LSB weight. This substitution only occurs for valid PCM time slots within frames for which this robbed bit has been designated. To determine which time slots are affected, the device monitors the frame sync (FS) pulse. The current frame is a robbed-bit frame and this half-LSB value is used only when this criteria is met:

- **The RBE bit is set, *and***
- **The device is in the μ -law companding mode, *and***
- **The current frame sync pulse (FS) is two PCLK cycles long, *and***
- **The previous frame sync pulse (FS) was *not* two PCLK cycles long.**

The frame sync pulse is sampled on the falling edge of PCLK. As shown in Figure 25, if the above criteria is met, and if FS is high for two consecutive falling edges of PCLK then low for the third falling edge, it is considered a robbed-bit frame. Otherwise, it is a normal frame.

Figure 25. Robbed-Bit Frame

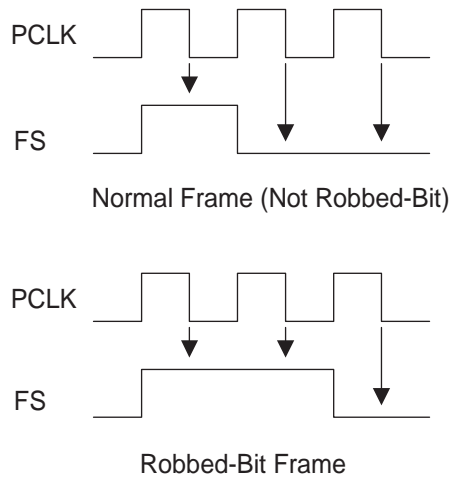

Default Filter Coefficients

The QLSLAC device contains an internal set of default coefficients for the programmable filters. The default filter gains are calculated based on the application circuit shown on [page 60](#). This SLIC device has a transmit gain of 0.5 (GTX) and a current gain of 500 (K1). The transmit relative level is set to +0.28 dBr, and the receive relative level is set to -4.39 dBr. The equalization filters (X and R) are not optimized and the Z and B filters are set to zero. The nominal input impedance was set to 812 Ω . If the SLIC device circuit differs significantly from this design, the default gains cannot be used and must be replaced by programmed coefficients. The balance filter (B) must always be programmed to an appropriate value.

To obtain this above-system response, the default filter coefficients are set to produce these values:

GX gain = +6 dB, GR gain = -8.984 dB

AX gain = 0 dB, AR gain = 0 dB, input attenuator on (DGIN = 0)

R filter: $H(z) = 1$, X filter: $H(z) = 1$

Z filter: $H(z) = 0$

B filter: $H(z) = 0$

AISN = cutoff

Notice that these default coefficient values are retained in a read-only memory area within the QLSLAC device, and those values cannot be read back using any data commands. When the device is selected to use default coefficients, it obtains those values directly from the read-only memory area, where the coefficient read operations access the programmable random access data memory only. If an attempt is made to read back any filter values without those values first being written with known programmed data, the values read back are totally random and do not represent the default or any other values.

COMMAND DESCRIPTION AND FORMATS

Command Field Summary

A microprocessor can program and control the QLSLAC device using the MPI. Data programmed previously can be read out for verification. See the tables below for the channel and global chip parameters assigned.

Commands are provided to assign values to the following channel parameters:

Table 3. Channel Parameters

Parameter	Description	MPI
TTS	Transmit time slot	40/41h
RTS	Receive time slot	42/43h
GX	Transmit gain	80/81h
GR	Receive loss	82/83h
B ₁	B ₁ filter coefficients	86/87h
B ₂	B ₂ filter coefficients	96/97h
X	X filter coefficients	88/89h
R	R filter coefficients	8A/8Bh
ZFIR	Z-FIR filter coefficients	98/99h
ZIIR	Z-IIR filter coefficients	9A/9Bh
Z	Z filter coefficients (both FIR and IIR)	84/85h
AISN	AISN coefficient	50/51h
CD1–C5	Write SLIC device Outputs	52h
IOD1–5	SLIC device Input/Output Direction	54/55h
A/μ	Select A-law or μ-law	60/61h
C/L	Compressed/linear	60/61h
TPCM	Select Transmit PCM highway A or B	40/41h
TAB	Select Transmit PCM on highway selected by TPCM, or on both ports A and B	44/45h
RPCM	Select Receive PCM Port A or B	42/43h
EB	Programmed/Default B filter	60/61h
EZ	Programmed/Default Z filter	60/61h
EX	Programmed/Default X filter	60/61h
ER	Programmed/Default R filter	60/61h
EGX	Programmed/Default GX filter	60/61h
EGR	Programmed/Default GR filter	60/61h
DGIN	Disable input attenuator	50/51h
AX	Enable/disable AX amplifier	50/51h
AR	Enable/disable AR amplifier	50/51h
CTP	Cutoff Transmit Path	70/71h
CRP	Cutoff Receive Path	70/71h
HPF	Disable High Pass Filter	70/71h
LRG	Lower Receive Gain	70/71h
ATI	Arm Transmit Interrupt	70/71h
ILB	Interface Loopback	70/71h
FDL	Full Digital Loopback	70/71h
TON	1 kHz Tone On	70/71h
GK	Ground-Key Filter	E8/E9h
CSTAT	Select Active or Inactive (Standby) state	55h, 00h, 0Eh

Commands are provided to read values from the following channel monitors:

Table 4. Channel Monitors

Monitor	Description	MPI
CD1–C5	Read SLIC device inputs	53h
CD1B	Multiplexed SLIC device Input	53h
XDAT	Transmit PCM data	CDh

Commands are provided to assign values to the following global chip parameters:

Table 5. Global Chip Parameters

Parameter	Description	MPI
XE	Transmit PCM Clock Edge	44/45h
RCS	Receive clock slot	44/45h
TCS	Transmit clock slot	44/45h
INTM	Interrupt Output Drive Mode	46/47h
CHP	Chopper Clock Frequency	46/47h
ECH	Enable Chopper Clock Output	C8/C9h
SMODE	Select Signaling on the PCM Highway	46/47h
CMODE	Select Master Clock Mode	46/47h
CSEL	Select Master Clock Frequency	46/47h
RBE	Robbed Bit Enable	4A/4Bh
VMODE	VOUT Mode	4A/4Bh
EC	Channel Enable Register	4A/4Bh
DSH	Debounce Time for CD1	C8/C9h
EE1	Enable E1 Output	C8/C9h
E1P	E1 Polarity	C8/C9h
MCDx _C	Interrupt Mask Register	6C/6Dh

Commands are provided to read values from the following global chip status monitors:

Table 6. Global Chip Status Monitors

Monitor	Description	MPI
CDX _C	Real Time Data Register	4D/4Fh
CFAIL	Clock Failure Bit	54/55h
RCN	Revision Code Number	73h

Microprocessor Interface Description

The following description of the MPI (Microprocessor Interface) is valid for channels 1 – 4. If desired, multiple channels can be programmed simultaneously with identical information by setting multiple Channel Enable bits. Channel enables are contained in the Channel Enable register and written or read using MPI Command 4A/4Bh. If multiple Channel Enable bits are set for a read operation, only data from the first enabled channel will be read.

The MPI physically consists of a serial data input/output (DIO), a data clock (DCLK), and a chip select (\overline{CS}). Individual Channel Enable bits EC1, EC2, EC3, and EC4 are stored internally in the Channel Enable register of the QLSLAC device. The serial input consists of 8-bit commands that can be followed with additional bytes of input data, or can be followed by the QLSLAC device sending out bytes of data. All data input and output is MSB (D7) first and LSB (D0) last. All data bytes are read or written one at a time, with \overline{CS} going High for at least a minimum off period before the next byte is read or written. Only a single channel should be enabled during read commands.

All commands that require additional input data to the device must have the input data as the next N words written into the device (for example, framed by the next N transitions of \overline{CS}). All unused bits must be programmed as 0 to ensure compatibility with future parts. All commands that are followed by output data will cause the device to output data for the next N transitions of \overline{CS} going Low. The QLSLAC device will not accept any commands until all the data has been shifted out. The output values of unused bits are not specified.

An MPI cycle is defined by transitions of \overline{CS} and DCLK. If the \overline{CS} lines are held in the High state between accesses, the DCLK may run continuously with no change to the internal control data. Using this method, the same DCLK can be run to a number of

QLSLAC devices and the individual \overline{CS} lines will select the appropriate device to access. Between command sequences, DCLK can stay in the High state indefinitely with no loss of internal control information regardless of any transitions on the \overline{CS} lines. Between bytes of a multibyte read or write command sequence, DCLK can also stay in the High state indefinitely. DCLK can stay in the Low state indefinitely with no loss of internal control information, provided the \overline{CS} lines remain at a High level.

If a low period of \overline{CS} contains less than 8 positive DCLK transitions, it is ignored. If it contains 8 to 15 positive transitions, only the last 8 transitions matter. If it contains 16 or more positive transitions, a hardware reset in the part occurs. If the chip is in the middle of a read sequence when \overline{CS} goes Low, data will be present at the DIO pin even if DCLK has no activity.

SUMMARY OF MPI COMMANDS

Hex*	Description
00h	Deactivate (Standby state)
02h	Software Reset
04h	Hardware Reset
06h	No Operation
0Eh	Activate (Operational state)
40/41h	Write/Read Transmit Time Slot and PCM Highway Selection
42/43h	Write/Read Receive Time Slot and PCM Highway Selection
44/45h	Write/Read REC & TX Clock Slot and TX Edge
46/47h	Write/Read Configuration Register
4A/4Bh	Write/Read Channel Enable & Operating Mode Register
4Dh	Read Real Time Data Register
4Fh	Read Real Time Data Register and Clear Interrupt
50/51h	Write/Read AISN and Analog Gains
52/53h	Write/Read SLIC device Input/Output Register
54/55h	Write/Read SLIC device Input/Output Direction and Status Bits
60/61h	Write/Read Operating Functions
6C/6Dh	Write/Read Interrupt Mask Register
70/71h	Write/Read Operating Conditions
73h	Read Revision Code Number (RCN)
80/81h	Write/Read GX Filter Coefficients
82/83h	Write/Read GR Filter Coefficients
84/85h	Write/Read Z Filter Coefficients (FIR and IIR)
86/87h	Write/Read B1 Filter Coefficients (FIR)
88/89h	Write/Read X Filter Coefficients
8A/8Bh	Write/Read R Filter Coefficients
96/97h	Write/Read B2 Filter Coefficients (IIR)
98/99h	Write/Read Z Filter Coefficients (FIR only)
9A/9Bh	Write/Read Z Filter Coefficients (IIR only)
C8/C9h	Write/Read Debounce Time Register
CDh	Read Transmit PCM Data
E8/E9h	Write/Read Ground Key Filter Sampling Interval

Note:

*All codes not listed are reserved by Legerity and should not be used.

MPI COMMAND STRUCTURE

This section details each MPI command. Each command is shown along with the format of any additional data bytes that follow. For details of the filter coefficients of the form $C_{xy}m_{xy}$, refer to the *General Description of CSD Coefficients* section [page 55](#).

Unused bits are indicated by "RSVD"; 0's should be written to them, but 0's are not guaranteed when they are read.

*Default field values are marked by an asterisk. A hardware reset forces the default values.

00h Deactivate (Standby State)

	D ₇	D ₆	D ₅	D ₄	D ₃	D ₂	D ₁	D ₀
Command	0	0	0	0	0	0	0	0

In the Deactivate (Standby) state:

All programmed information is retained.

The Microprocessor Interface (MPI) remains active.

The PCM inputs are disabled and the PCM outputs are high impedance unless signaling on the PCM highway is programmed (SMODE = 1).

The analog output (VOUT) is disabled and biased at VREF.

The channel status (CSTAT) bit in the SLIC device I/O Direction and Channel Status Register is set to 0.

02h Software Reset

	D ₇	D ₆	D ₅	D ₄	D ₃	D ₂	D ₁	D ₀
Command	0	0	0	0	0	0	1	0

The action of this command is identical to that of the $\overline{\text{RST}}$ pin except that it only operates on the channels selected by the Channel Enable Register and it does not change clock slots, time slots, PCM highways ground key sampling interval, or global chip parameters. See the note under the hardware reset command that follows.

04h Hardware Reset

	D ₇	D ₆	D ₅	D ₄	D ₃	D ₂	D ₁	D ₀
Command	0	0	0	0	0	1	0	0

Hardware reset is equivalent to pulling the $\overline{\text{RST}}$ on the device Low. This command does not depend on the state of the Channel Enable Register.

Note:

The action of a hardware reset is described in Reset States on [page 31](#) of the section Operating the QLSLAC Device.

06h No Operation

	D ₇	D ₆	D ₅	D ₄	D ₃	D ₂	D ₁	D ₀
Command	0	0	0	0	0	1	1	0

0Eh Activate Channel (Operational State)

	D ₇	D ₆	D ₅	D ₄	D ₃	D ₂	D ₁	D ₀
Command	0	0	0	0	1	1	1	0

This command places the device in the Active state and sets CSTAT = 1. No valid PCM data is transmitted until after the third FS pulse is received following the execution of the Activate command.

40/41h Write/Read Transmit Time Slot and PCM Highway Selection

R/W = 0: Write

R/W = 1: Read

	D ₇	D ₆	D ₅	D ₄	D ₃	D ₂	D ₁	D ₀
Command	0	1	0	0	0	0	0	R/W
I/O Data	TPCM	TTS6	TTS5	TTS4	TTS3	TTS2	TTS1	TTS0

Transmit PCM Highway

TPCM = 0* Transmit on Highway A (see TAB in Command 44/45h)

TPCM = 1 Transmit on Highway B (see TAB in Command 44/45h)

Transmit Time Slot

TTS = 0–127 Time Slot Number (TTS0 is LSB, TTS6 is MSB)

PCM Highway B is not available on the Le58QL021/031 QLSLAC devices.

* Power Up and Hardware Reset (\overline{RST}) Value = 00h, 01h, 02h, 03h for Channels 1, 2, 3, and 4, respectively.

42/43h Write/Read Receive Time Slot and PCM Highway Selection

R/W = 0: Write

R/W = 1: Read

	D ₇	D ₆	D ₅	D ₄	D ₃	D ₂	D ₁	D ₀
Command	0	1	0	0	0	0	1	R/W
I/O Data	RPCM	RTS6	RTS5	RTS4	RTS3	RTS2	RTS1	RTS0

Receive PCM Highway

RPCM = 0* Receive on Highway A

RPCM = 1 Receive on Highway B

Receive Time Slot

RTS = 0–127 Time Slot Number (RTS0 is LSB, RTS6 is MSB)

PCM Highway B is not available on the Le58QL021 and the Le58QL031 QLSLAC devices.

* Power Up and Hardware Reset (\overline{RST}) Value = 00h, 01h, 02h, 03h for channels 1, 2, 3, and 4, respectively.

44/45h Write/Read Transmit Clock Slot, Receive Clock Slot, and Transmit Clock Edge

R/W = 0: Write

R/W = 1: Read

	D ₇	D ₆	D ₅	D ₄	D ₃	D ₂	D ₁	D ₀
Command	0	1	0	0	0	1	0	R/W
I/O Data	TAB	XE	RCS2	RCS1	RCS0	TCS2	TCS1	TCS0

Transmit on A and B

TAB = 0* Transmit data on highway selected by TPCM (See Command 40/41h on [page 41](#)).

TAB = 1 Transmit data on both highways A and B

Transmit Edge

XE = 0* Transmit changes on negative edge of PCLK

XE = 1 Transmit changes on positive edge of PCLK

Receive Clock Slot

RCS = 0*–7 Receive Clock Slot number

Transmit Clock Slot

TCS = 0*–7 Transmit Clock Slot number

The XE bit and the clock slots apply to all four channels; however, they cannot be written or read unless at least one channel is selected in the Channel Enable Register.

* Power Up and Hardware Reset (\overline{RST}) Value = 00h.

46/47h Write/Read Chip Configuration Register

R/W = 0: Write

R/W = 1: Read

	D ₇	D ₆	D ₅	D ₄	D ₃	D ₂	D ₁	D ₀
Command	0	1	0	0	0	1	1	R/W
I/O Data	INTM	CHP	SMODE	CMODE	CSEL3	CSEL2	CSEL1	CSEL0

Interrupt Mode

INTM = 0 TTL-compatible output
 INTM = 1* Open drain output

Chopper Clock Control

CHP = 0* Chopper Clock is 256 kHz (2048/8 kHz)
 CHP = 1 Chopper Clock is 292.57 kHz (2048/7 kHz)

PCM Signaling Mode

SMODE = 0* No signaling on PCM highway
 SMODE = 1 Signaling on PCM highway

Clock Source Mode

CMODE = 0 MCLK used as master clock; no E1 multiplexing allowed
 CMODE = 1* PCLK used as master clock; E1 multiplexing allowed if enabled in commands C8/C9h.

The master clock frequency can be selected by CSEL. The master clock frequency selection affects all channels.

Master Clock Frequency

CSEL = 0000 1.536 MHz
 CSEL = 0001 1.544 MHz
 CSEL = 0010 2.048 MHz
 CSEL = 0011 Reserved
 CSEL = 01xx Two times frequency specified above (2 x 1.536 MHz,
 2 x 1.544 MHz, or 2 x 2.048 MHz)
 CSEL = 10xx Four times frequency specified above (4 x 1.536 MHz,
 4 x 1.544 MHz, or 4 x 2.048 MHz)
 CSEL = 11xx Reserved
 CSEL = 1010* 8.192 MHz is the default

These commands do not depend on the state of the Channel Enable Register.

* Power Up and Hardware Reset (RST) Value = 9Ah.

4A/4Bh Write/Read Channel Enable and Operating Mode Register

R/W = 0: Write

R/W = 1: Read

	D ₇	D ₆	D ₅	D ₄	D ₃	D ₂	D ₁	D ₀
Command	0	1	0	0	1	0	1	R/W
I/O Data	RSVD	RBE	VMODE	LPM	EC4	EC3	EC2	EC1

Robbed-bit Mode	RSVD	Reserved for future use. Always write as 0, but 0 is not guaranteed when read.
	RBE = 0*	Robbed-bit Signaling mode is disabled.
	RBE = 1	Robbed-bit Signaling mode is enabled on PCM receiver if μ -law is selected.
VOUT Mode	VMODE = 0*	VOUT = VREF through a resistor when channel is deactivated
	VMODE = 1	VOUT high impedance when channel is deactivated.
Low Power Mode	LPM	LPM reduced the power in the QSLAC device, but it is not needed and not used in the QLSLAC device
Channel Enable 4	EC4 = 0	Disabled, channel 4 cannot receive commands
	EC4 = 1*	Enabled, channel 4 can receive commands
Channel Enable 3	EC3 = 0	Disabled, channel 3 cannot receive commands
	EC3 = 1*	Enabled, channel 3 can receive commands
Channel Enable 2	EC2 = 0	Disabled, channel 2 cannot receive commands
	EC2 = 1*	Enabled, channel 2 can receive commands
Channel Enable 1	EC1 = 0	Disabled, channel 1 cannot receive commands
	EC1 = 1*	Enabled, channel 1 can receive commands

* Power Up and Hardware Reset ($\overline{\text{RST}}$) Value = 0Fh.

4D/4Fh Read Real-Time Data Register

C = 0: Do not clear interrupt

C = 1: Clear interrupt

This register reads real-time data with or without clearing the interrupt.

	D ₇	D ₆	D ₅	D ₄	D ₃	D ₂	D ₁	D ₀
Command	0	1	0	0	1	1	C	1
Output Data	CDB4	CDA4	CDB3	CDA3	CDB2	CDA2	CDB1	CDA1

Real Time Data

CDA1	Debounced data bit 1 on channel 1
CDB1	Data bit 2 or multiplexed data bit 1 on channel 1
CDA2	Debounced data bit 1 on channel 2
CDB2	Data bit 2 or multiplexed data bit 1 on channel 2
CDA3	Debounced data bit 1 on channel 3
CDB3	Data bit 2 or multiplexed data bit 1 on channel 3
CDA4	Debounced data bit 1 on channel 4
CDB4	Data bit 2 or multiplexed data bit 1 on channel 4

This command does not depend on the state of the Channel Enable Register.

50/51h Write/Read AISN and Analog Gains

R/W = 0: Write

R/W = 1: Read

	D ₇	D ₆	D ₅	D ₄	D ₃	D ₂	D ₁	D ₀
Command	0	1	0	1	0	0	0	R/W
I/O Data	DGIN	AX	AR	AISN4	AISN3	AISN2	AISN1	AISN0

Disable Input Attenuator (GIN)

DGIN = 0* Input attenuator on
 DGIN = 1 Input attenuator off

Transmit Analog Gain

AX = 0* 0 dB gain
 AX = 1 6.02 dB gain

Receive Analog Loss

AR = 0* 0 dB loss
 AR = 1 6.02 dB loss

AISN coefficient

AISN = 0* – 31 See below (Default value = 0)

The Impedance Scaling Network (AISN) gain can be varied from $-0.9375 \cdot \text{GIN}$ to $+0.9375 \cdot \text{GIN}$ in multiples of $0.0625 \cdot \text{GIN}$.

The gain coefficient is decoded using the following equation:

$$h_{\text{AISN}} = 0.0625 \cdot \text{GIN} [(16 \cdot \text{AISN4} + 8 \cdot \text{AISN3} + 4 \cdot \text{AISN2} + 2 \cdot \text{AISN1} + \text{AISN0}) - 16]$$

where h_{AISN} is the gain of the AISN. A value of AISN = 10000 turns on the Full Digital Loopback mode and a value of AISN = 0000* indicates a gain of 0 (cutoff).

* Power Up and Hardware Reset ($\overline{\text{RST}}$) Value = 00h.

52/53h Write/Read SLIC Device Input/Output Register

R/W = 0: Write

R/W = 1: Read

	D ₇	D ₆	D ₅	D ₄	D ₃	D ₂	D ₁	D ₀
Command	0	1	0	1	0	0	1	R/W
I/O Data	RSVD	RSVD	CD1B	C5	C4	C3	CD2	CD1

RSVD Reserved for future use. Always write as 0, but 0 is not guaranteed when read.

Pins CD1, CD2, and C3 through C5 are set to 1 or 0. The data appears latched on the CD1, CD2, and C3 through C5 SLIC device I/O pins, provided they were set in the Output mode (see Command 54/55h on page [page 44](#)). The data sent to any of the pins set to the Input mode is latched, but does not appear at the pins. The CD1B bit is only valid if the E1 Multiplex mode is enabled (EE1 = 1).

* Power Up and Hardware Reset ($\overline{\text{RST}}$) Value = 00h

54/55h Write/Read SLIC Input/Output Direction, Read Status Bits

R/W = 0: Write

R/W = 1: Read

	D ₇	D ₆	D ₅	D ₄	D ₃	D ₂	D ₁	D ₀
Command	0	1	0	1	0	1	0	R/W
Input Data	RSVD	CSTAT	CFAIL	IOD5	IOD4	IOD3	IOD2	IOD1

RSVD Reserved for future use. Always write as 0, but 0 is not guaranteed when read.

Channel Status (Read status only, write as 0)

CSTAT = 0 Channel is inactive (Standby state).
 CSTAT = 1 Channel is active.

Clock Fail (Read status only, write as 0)

CFAIL* = 0 The internal clock is synchronized to frame synch.
 CFAIL = 1 The internal clock is not synchronized to frame synch.

* The CFAIL bit is independent of the Channel Enable Register.

I/O Direction (Read/Write)

IOD5 = 0* C5 is an input
 IOD5 = 1 C5 is an output
 IOD4 = 0* C4 is an input
 IOD4 = 1 C4 is an output
 IOD3 = 0* C3 is an input
 IOD3 = 1 C3 is an output
 IOD2 = 0* CD2 is an input
 IOD2 = 1 CD2 is an output
 IOD1 = 0* CD1 is an input
 IOD1 = 1 CD1 is an output

Pins CD1, CD2, and C3 through C5 are set to Input or Output modes individually. Pins C3–C5 are not available on the Le58QL031 QLSLAC device, and C5 is available only on the Le58QL021 QLSLAC device.

* Power Up and Hardware Reset ($\overline{\text{RST}}$) Value = 00h

60/61h Write/Read Operating Functions

R/W = 0: Write

R/W = 1: Read

	D ₇	D ₆	D ₅	D ₄	D ₃	D ₂	D ₁	D ₀
Command	0	1	1	0	0	0	0	R/W
I/O Data	C/L	A/ μ	EGR	EGX	EX	ER	EZ	EB

Linear Code

C/L = 0* Compressed coding
 C/L = 1 Linear coding

A-law or μ -law

A/ μ = 0* A-law coding
 A/ μ = 1 μ -law coding

GR Filter

EGR = 0* Default GR filter enabled
 EGR = 1 Programmed GR filter enabled

GX Filter

EGX = 0* Default GX filter enabled
 EGX = 1 Programmed GX filter enabled

X Filter

EX = 0* Default X filter enabled
 EX = 1 Programmed X filter enabled

R Filter

ER = 0* Default R filter enabled
 ER = 1 Programmed R filter enabled

Z Filter

EZ = 0* Default Z filter enabled
 EZ = 1 Programmed Z filter enabled

B Filter

EB = 0* Default B filter enabled
 EB = 1 Programmed B filter enabled

* Power Up and Hardware Reset ($\overline{\text{RST}}$) Value = 00h.

6C/6Dh Write/Read Interrupt Mask Register

R/W = 0: Write

R/W = 1: Read

	D ₇	D ₆	D ₅	D ₄	D ₃	D ₂	D ₁	D ₀
Command	0	1	1	0	1	1	0	R/W
I/O Data	MCDB4	MCDA4	MCDB3	MCDA3	MCDB2	MCDA2	MCDB1	MCDA1

Mask CD Interrupt

$MCDx_C = 0$ CDx_C bit is NOT MASKED
 $MCDx_C = 1^*$ CDx_C bit is MASKED
 x Bit number (A or B)
 C Channel number (1 through 4)
 Masked: A change does not cause the Interrupt Pin to go Low.

This command does not depend on the state of the Channel Enable Register.

* Power Up and Hardware Reset (RST) Value = FFh.

70/71h Write/Read Operating Conditions

R/W = 0: Write

R/W = 1: Read

	D ₇	D ₆	D ₅	D ₄	D ₃	D ₂	D ₁	D ₀
Command	0	1	1	1	0	0	0	R/W
I/O Data	CTP	CRP	HPF	LRG	ATI	ILB	FDL	TON

Cutoff Transmit Path

$CTP = 0^*$ Transmit path connected
 $CTP = 1$ Transmit path cut off

Cutoff Receive Path

$CRP = 0^*$ Receive path connected
 $CRP = 1$ Receive path cutoff (see note)

High Pass Filter

$HPF = 0^*$ Transmit Highpass filter enabled
 $HPF = 1$ Transmit Highpass filter disabled

Lower Receive Gain

$LRG = 0^*$ 6 dB loss not inserted
 $LRG = 1$ 6 dB loss inserted

Arm Transmit Interrupt

$ATI = 0^*$ Transmit Interrupt not Armed
 $ATI = 1$ Transmit Interrupt Armed

Interface Loopback

$ILB = 0^*$ TSA loopback disabled
 $ILB = 1$ TSA loopback enabled

Full Digital Loopback

$FDL = 0^*$ Full digital loopback disabled
 $FDL = 1$ Full digital loopback enabled

1 kHz Receive Tone

$TON = 0^*$ 1 kHz receive tone off
 $TON = 1$ 1 kHz receive tone on

* Power Up and Hardware Reset (\overline{RST}) Value = 00h.

The B Filter is disabled during receive cutoff.

73h Read Revision Code Number (RCN)

	D ₇	D ₆	D ₅	D ₄	D ₃	D ₂	D ₁	D ₀
Command	0	1	1	1	0	0	1	1
I/O Data	RCN7	RCN6	RCN5	RCN4	RCN3	RCN2	RCN1	RCN0

This command returns an 8-bit number (RCN) describing the revision number of the QLSLAC device. The revision code of the QLSLAC device will be 14h or higher. This command does not depend on the state of the Channel Enable Register.

80/81h Write/Read GX Filter Coefficients

R/W = 0: Write

R/W = 1: Read

	D ₇	D ₆	D ₅	D ₄	D ₃	D ₂	D ₁	D ₀
Command	1	0	0	0	0	0	0	R/W
I/O Data Byte 1	C40	m40			C30	m30		
I/O Data Byte 2	C20	m20			C10	m10		

C_{xy} = 0 or 1 in the command above corresponds to C_{xy} = +1 or -1, respectively, in the equation below.

The coefficient for the GX filter is defined as: $H_{GX} = 1 + (C10 \cdot 2^{-m10} \{1 + C20 \cdot 2^{-m20} [1 + C30 \cdot 2^{-m30} (1 + C40 \cdot 2^{-m40})]\})$

Power Up and Hardware Reset (RST) Values = A9F0 (Hex) (H_{GX} = 1.995 (6 dB)).

Note:

The default value is contained in a ROM register separate from the programmable coefficient RAM. There is a filter enable bit in Operating Functions Register to switch between the default and programmed values.

82/83h Write/Read GR Filter Coefficients

R/W = 0: Write

R/W = 1: Read

	D ₇	D ₆	D ₅	D ₄	D ₃	D ₂	D ₁	D ₀
Command:	1	0	0	0	0	0	1	R/W
I/O Data Byte 1	C40	m40			C30	m30		
I/O Data Byte 2	C20	m20			C10	m10		

C_{xy} = 0 or 1 in the command above corresponds to C_{xy} = +1 or -1, respectively, in the equation below.

The coefficient for the GR filter is defined as:

$$H_{GR} = C10 \cdot 2^{-m10} \{1 + C20 \cdot 2^{-m20} [1 + C30 \cdot 2^{-m30} (1 + C40 \cdot 2^{-m40})]\}$$

Power Up and Hardware Reset (RST) Values = 23A1 (Hex) (H_{GR} = 0.35547 (-8.984 dB)).

See note under Command 80/81h, above.

84/85h Write/Read Z Filter Coefficients (FIR and IIR)

R/W = 0: Write

R/W = 1: Read

This command writes and reads both the FIR and IIR filter sections simultaneously.

	D ₇	D ₆	D ₅	D ₄	D ₃	D ₂	D ₁	D ₀
Command	1	0	0	0	0	1	0	R/W
I/O Data Byte 1	C40	m40			C30	m30		
I/O Data Byte 2	C20	m20			C10	m10		
I/O Data Byte 3	C41	m41			C31	m31		
I/O Data Byte 4	C21	m21			C11	m11		
I/O Data Byte 5	C42	m42			C32	m32		
I/O Data Byte 6	C22	m22			C12	m12		
I/O Data Byte 7	C43	m43			C33	m33		
I/O Data Byte 8	C23	m23			C13	m13		
I/O Data Byte 9	C44	m44			C34	m34		
I/O Data Byte 10	C24	m24			C14	m14		
I/O Data Byte 11	C45	m45			C35	m35		
I/O Data Byte 12	C25	m25			C15	m15		
I/O Data Byte 13	C26	m26			C16	m16		
I/O Data Byte 14	C47	m47			C37	m37		
I/O Data Byte 15	C27	m27			C17	m17		

C_{xy} = 0 or 1 in the command above corresponds to C_{xy} = +1 or -1, respectively, in the equation below.

The Z-transform equation for the Z filter is defined as: $H_z(z) = z_0 + z_1 \cdot z^{-1} + z_2 \cdot z^{-2} + z_3 \cdot z^{-3} + z_4 \cdot z^{-4} + \frac{z_5 \cdot z_6 \cdot z_7 \cdot z^{-1}}{1 - z_7 \cdot z^{-1}}$

Sample rate = 32 kHz

For i = 0 to 5 and 7 $z_i = C1i \cdot 2^{-m1i} \{1 + C2i \cdot 2^{-m2i} [1 + C3i \cdot 2^{-m3i} (1 + C4i \cdot 2^{-m4i})]\}$

$$z_6 = C16 \cdot 2^{-m16} \{1 + C26 \cdot 2^{-m26}\}$$

Power Up and Hardware Reset (RST) Values = 0190 0190 0190 0190 0190 0190 01 0190 (Hex)

(H_z(z) = 0)

See note under Command 80/81h on [page 47](#).

Note:

Z₆ is used for IIR filter scaling only. Its value is typically greater than zero but less than or equal to one. The input to the IIR filter section is first increased by a gain of 1/Z₆, improving dynamic range and avoiding truncation limitations through processing within this filter. The IIR filter output is then multiplied by Z₆ to normalize the overall gain. Z₅ is the actual IIR filter gain value defined by the programmed coefficients, but it also includes the initial 1/Z₆ gain. The theoretical effective IIR gain, without the Z₆ gain and normalization, is actually Z₅/Z₆.

86/87h Write/Read B1 Filter Coefficients

R/W = 0: Write

R/W = 1: Read

	D ₇	D ₆	D ₅	D ₄	D ₃	D ₂	D ₁	D ₀
Command	1	0	0	0	0	1	1	R/W
I/O Input Data Byte 1	C32	m32			C22	m22		
I/O Input Data Byte 2	C12	m12			C33	m33		
I/O Input Data Byte 3	C23	m23			C13	m13		
I/O Input Data Byte 4	C34	m34			C24	m24		
I/O Input Data Byte 5	C14	m14			C35	m35		
I/O Input Data Byte 6	C25	m25			C15	m15		
I/O Input Data Byte 7	C36	m36			C26	m26		
I/O Input Data Byte 8	C16	m16			C37	m37		
I/O Input Data Byte 9	C27	m27			C17	m17		
I/O Input Data Byte 10	C38	m38			C28	m28		
I/O Input Data Byte 11	C18	m18			C39	m39		
I/O Input Data Byte 12	C29	m29			C19	m19		
I/O Input Data Byte 13	C310	m310			C210	m210		
I/O Input Data Byte 14	C110	m110			RSVD	RSVD		

C_{xy} = 0 or 1 in the command above corresponds to C_{xy} = +1 or -1, respectively, in the equation below.

The Z-transform equation for the B filter is defined as:

$$H_B(z) = B_2 \cdot z^{-2} + \dots + B_9 \cdot z^{-9} + \frac{B_{10} \cdot z^{-10}}{1 - B_{11} \cdot z^{-1}}$$

Sample rate = 16 kHz

The coefficients for the FIR B section and the gain of the IIR B section are defined as:

For i = 2 to 10,

$$B_i = C1i \cdot 2^{-m1i} [1 + C2i \cdot 2^{-m2i} (1 + C3i \cdot 2^{-m3i})]$$

The feedback coefficient of the IIR B section is defined as

$$B_{11} = C111 \cdot 2^{-m111} \{1 + C211 \cdot 2^{-m211} [1 + C311 \cdot 2^{-m311} (1 + C411 \cdot 2^{-m411})]\}$$

Refer to Command 96/97h for programming of the B₁₁ coefficients.

Power Up and Hardware Reset (\overline{RST}) Values = 09 00 90 09 00 90 09 00 90 09 00 90 09 00 (Hex)

$$H_B(z) = 0$$

See note under Command 80/81h on [page 47](#).

RSVD Reserved for future use. Always write as 0, but 0 is not guaranteed when read.

88/89h Write/Read X Filter Coefficients

R/W = 0: Write

R/W = 1: Read

	D ₇	D ₆	D ₅	D ₄	D ₃	D ₂	D ₁	D ₀
Command	1	0	0	0	1	0	0	R/W
I/O Input Data Byte 1	C40	m40			C30	m30		
I/O Input Data Byte 2	C20	m20			C10	m10		
I/O Input Data Byte 3	C41	m41			C31	m31		
I/O Input Data Byte 4	C21	m21			C11	m11		
I/O Input Data Byte 5	C42	m42			C32	m32		
I/O Input Data Byte 6	C22	m22			C12	m12		
I/O Input Data Byte 7	C43	m43			C33	m33		
I/O Input Data Byte 8	C23	m23			C13	m13		
I/O Input Data Byte 9	C44	m44			C34	m34		
I/O Input Data Byte 10	C24	m24			C14	m14		
I/O Input Data Byte 11	C45	m45			C35	m35		
I/O Input Data Byte 12	C25	m25			C15	m15		

C_{xy} = 0 or 1 in the command above corresponds to C_{xy} = +1 or -1, respectively, in the equation below.
The Z-transform equation for the X filter is defined as:

$$H_x(z) = x_0 + x_1z^{-1} + x_2z^{-2} + x_3z^{-3} + x_4z^{-4} + x_5z^{-5}$$

Sample rate = 16 kHz

For i = 0 to 5, the coefficients for the X filter are defined as:

$$X_i = C_{1i} \cdot 2^{-m_{1i}} \{ 1 + C_{2i} \cdot 2^{-m_{2i}} [1 + C_{3i} \cdot 2^{-m_{3i}} (1 + C_{4i} \cdot 2^{-m_{4i}})] \}$$

Power Up and Hardware Reset (\overline{RST}) Values = 0111 0190 0190 0190 0190 0190 (Hex)
($H_x(z) = 1$)

See note under Command 80/81h on [page 47](#).

8A/8Bh Write/Read R Filter Coefficients

R/W = 0: Write

R/W = 1: Read

	D ₇	D ₆	D ₅	D ₄	D ₃	D ₂	D ₁	D ₀
Command	1	0	0	0	1	0	1	R/W
I/O Input Data Byte 1	C46	m46			C36	m36		
I/O Input Data Byte 2	C26	m26			C16	m16		
I/O Input Data Byte 3	C40	m40			C30	m30		
I/O Input Data Byte 4	C20	m20			C10	m10		
I/O Input Data Byte 5	C41	m41			C31	m31		
I/O Input Data Byte 6	C21	m21			C11	m11		
I/O Input Data Byte 7	C42	m42			C32	m32		
I/O Input Data Byte 8	C22	m22			C12	m12		
I/O Input Data Byte 9	C43	m43			C33	m33		
I/O Input Data Byte 10	C23	m23			C13	m13		
I/O Input Data Byte 11	C44	m44			C34	m34		
I/O Input Data Byte 12	C24	m24			C14	m14		
I/O Input Data Byte 13	C45	m45			C35	m35		
I/O Input Data Byte 14	C25	m25			C15	m15		

C_{xy} = 0 or 1 in the command above corresponds to C_{xy} = +1 or -1, respectively, in the equation below.

$$HR = H_{IIR} \cdot H_{FIR}$$

The Z-transform equation for the IIR filter is defined as:

$$H_{IIR} = \frac{1 - z^{-1}}{1 - (R_6 \cdot z^{-1})}$$

Sample rate = 8 kHz

The coefficient for the IIR filter is defined as:

$$R_6 = C16 \cdot 2^{-m16} \{1 + C26 \cdot 2^{-m26} [1 + C36 \cdot 2^{-m36} (1 + C46 \cdot 2^{-m46})]\}$$

The Z-transform equation for the FIR filter is defined as:

$$H_{FIR}(z) = R_0 + R_1 z^{-1} + R_2 z^{-2} + R_3 z^{-3} + R_4 z^{-4} + R_5 z^{-5}$$

Sample rate = 16 kHz

For i = 0 to 5, the coefficients for the R2 filter are defined as:

$$R_i = C1i \cdot 2^{-m1i} \{1 + C2i \cdot 2^{-m2i} [1 + C3i \cdot 2^{-m3i} (1 + C4i \cdot 2^{-m4i})]\}$$

Power Up and Hardware Reset (\overline{RST}) Values = 2E01 0111 0190 0190 0190 0190 0190 (Hex)

$$(H_{FIR}(z) = 1, R_6 = 0.9902)$$

See note under Command 80/81h on [page 47](#).

96/97h Write/Read B2 Filter Coefficients (IIR)

R/W = 0: Write

R/W = 1: Read

	D ₇	D ₆	D ₅	D ₄	D ₃	D ₂	D ₁	D ₀
Command	1	0	0	1	0	1	1	R/W
I/O Data Byte 1	C411	m411			C311	m311		
I/O Data Byte 2	C211	m211			C111	m111		

This function is described in *Write/Read B1 Filter Coefficients (FIR)* on [page 49](#).

Power Up and Hardware Reset ($\overline{\text{RST}}$) Values = 0190 (Hex) (B₁₁ = 0)

See note under Command 80/81h on [page 47](#).

98/99h Write/Read FIR Z Filter Coefficients (FIR only)

R/W = 0: Write

R/W = 1: Read

This command writes and reads only the FIR filter section without affecting the IIR.

	D ₇	D ₆	D ₅	D ₄	D ₃	D ₂	D ₁	D ₀
Command	1	0	0	1	1	0	0	R/W
I/O Data Byte 1	C40	m40			C30	m30		
I/O Data Byte 2	C20	m20			C10	m10		
I/O Data Byte 3	C41	m41			C31	m31		
I/O Data Byte 4	C21	m21			C11	m11		
I/O Data Byte 5	C42	m42			C32	m32		
I/O Data Byte 6	C22	m22			C12	m12		
I/O Data Byte 7	C43	m43			C33	m33		
I/O Data Byte 8	C23	m23			C13	m13		
I/O Data Byte 9	C44	m44			C34	m34		
I/O Data Byte 10	C24	m24			C14	m14		

C_{xy} = 0 or 1 in the command above corresponds to C_{xy} = +1 or -1, respectively, in the equation below.

The Z-transform equation for the Z filter is defined as:

$$H_z(z) = z_0 + z_1 \cdot z^{-1} + z_2 \cdot z^{-2} + z_3 \cdot z^{-3} + z_4 \cdot z^{-4} + \frac{z_5 \cdot z_6 \cdot z_7 \cdot z^{-1}}{1 - z_7 \cdot z^{-1}}$$

Sample rate = 32 kHz

For i = 0 to 5 and 7

$$z_i = C1i \cdot 2^{-m1i} \{1 + C2i \cdot 2^{-m2i} [1 + C3i \cdot 2^{-m3i} (1 + C4i \cdot 2^{-m4i})]\}$$

$$z_6 = C16 \cdot 2^{-m16} \{1 + C26 \cdot 2^{-m26}\}$$

Power Up and Hardware Reset ($\overline{\text{RST}}$) Values = 0190 0190 0190 0190 0190 0190 01 0190 (Hex)

(H_z(z) = 0)

See note under Command 80/81h on [page 47](#).

Note:

Z₆ is used for IIR filter scaling only. Its value is typically greater than zero but less than or equal to one. The input to the IIR filter section is first increased by a gain of 1/Z₆, improving dynamic range and avoiding truncation limitations through processing within this filter. The IIR filter output

is then multiplied by Z_6 to normalize the overall gain. Z_5 is the actual IIR filter gain value defined by the programmed coefficients, but it also includes the initial $1/Z_6$ gain. The theoretical effective IIR gain, without the Z_6 gain and normalization, is actually Z_5/Z_6 .

9A/9Bh Write/Read IIR Z Filter Coefficients (IIR only)

R/W = 0: Write

R/W = 1: Read

This command writes/reads the IIR filter section only, without affecting the FIR.

	D ₇	D ₆	D ₅	D ₄	D ₃	D ₂	D ₁	D ₀
Command	1	0	0	1	1	0	1	R/W
I/O Data Byte 1	C45	m45			C35	m35		
I/O Data Byte 2	C25	m25			C15	m15		
I/O Data Byte 3	C26	m26			C16	m16		
I/O Data Byte 4	C47	m47			C37	m37		
I/O Data Byte 5	C27	m27			C17	m17		

$C_{xy} = 0$ or 1 in the command above corresponds to $C_{xy} = +1$ or -1 , respectively, in the equation below.

The Z-transform equation for the Z filter is defined as:

$$H_z(z) = z_0 + z_1 \cdot z^{-1} + z_2 \cdot z^{-2} + z_3 \cdot z^{-3} + z_4 \cdot z^{-4} + \frac{z_5 \cdot z_6 \cdot z_7 \cdot z^{-1}}{1 - z_7 \cdot z^{-1}}$$

Sample rate = 32 kHz

For $i = 0$ to 5 and 7

$$z_i = C1i \cdot 2^{-m1i} \{1 + C2i \cdot 2^{-m2i} [1 + C3i \cdot 2^{-m3i} (1 + C4i \cdot 2^{-m4i})]\}$$

$$z_6 = C16 \cdot 2^{-m16} \{1 + C26 \cdot 2^{-m26}\}$$

Power Up and Hardware Reset ($\overline{\text{RST}}$) Values = 0190 0190 0190 0190 0190 0190 01 0190 (Hex)

($H_z(z) = 0$)

See note under Command 80/81h on [page 47](#).

Note:

Z_6 is used for IIR filter scaling only. Its value is typically greater than zero but less than or equal to one. The input to the IIR filter section is first increased by a gain of $1/Z_6$, improving dynamic range and avoiding truncation limitations through processing within this filter. The IIR filter output is then multiplied by Z_6 to normalize the overall gain. Z_5 is the actual IIR filter gain value defined by the programmed coefficients, but it also includes the initial $1/Z_6$ gain. The theoretical effective IIR gain, without the Z_6 gain and normalization, is actually Z_5/Z_6 .

C8/C9h Write/Read Debounce Time Register

This command applies to *all* channels and does not depend on the state of the Channel Enable Register.

R/W = 0: Write

R/W = 1: Read

	D ₇	D ₆	D ₅	D ₄	D ₃	D ₂	D ₁	D ₀
Command	1	1	0	0	1	0	0	R/W
I/O Data	EE1	E1P	DSH3	DSH2	DSH1	DSH0	RSVD	ECH

Enable E1

EE1 = 0* E1 multiplexing turned off
EE1 = 1 E1 multiplexing turned on

E1 Polarity

E1P = 0* E1 is a high-going pulse
E1P = 1 E1 is a low-going pulse

There is no E1 output unless CMODE = 1.

Debounce for hook switch

DSH = 0–15 Debounce period in ms

DSH contains the debouncing time (in ms) of the CD1 data (usually hook switch) entering the Real Time Data register described earlier. The input data must remain stable for the debouncing time in order to change the appropriate real time bit.

Default = 8 ms

RSVD

Reserved for future use. Always write as 0, but 0 is not guaranteed when read.

Enable Chopper

ECH = 0* Chopper output (CHCLK) turned off

ECH = 1 Chopper output (CHCLK) turned on

* Power Up and Hardware Reset ($\overline{\text{RST}}$) Value = 20h.

CDh Read Transmit PCM Data

	D ₇	D ₆	D ₅	D ₄	D ₃	D ₂	D ₁	D ₀
Command	1	1	0	0	1	1	0	1
Output Data Byte 1	XDAT7	XDAT6	XDAT5	XDAT4	XDAT3	XDAT2	XDAT1	XDAT0
Output Data Byte 2	RSVD	RSVD	RSVD	RSVD	RSVD	RSVD	RSVD	RSVD

RSVD

Reserved for future use. Always write as 0, but 0 is not guaranteed when read.

Upper Transmit Data

XDAT contains A-law or μ -law transmit data in Companded mode.

XDAT contains upper data byte in Linear mode with sign in XDAT7.

E8/E9h Write/Read Ground Key Filter

R/W = 0: Write

R/W = 1: Read

	D ₇	D ₆	D ₅	D ₄	D ₃	D ₂	D ₁	D ₀
Command	1	1	1	0	1	0	0	R/W
I/O Data	RSVD	RSVD	RSVD	RSVD	GK3	GK2	GK1	GK0

Filter Ground Key

GK = 0–15 Filter sampling period in 1 ms

GK contains the filter sampling time (in ms) of the CD1B data (usually Ground Key) or CD2 entering the Real Time Data register described earlier. A value of 0 disables the Ground Key filter for that particular channel.

Power Up and Hardware Reset ($\overline{\text{RST}}$) Value = x0h.

RSVD

Reserved for future use. Always write as 0, but 0 is not guaranteed when read.

PROGRAMMABLE FILTERS

General Description of CSD Coefficients

The filter functions are performed by a series of multiplications and accumulations. A multiplication occurs by repeatedly shifting the multiplicand and summing the result with the previous value at that summation node. The method used in the QLSLAC device is known as Canonic Signed Digit (CSD) multiplication and splits each coefficient into a series of CSD coefficients.

Each programmable FIR filter section has the following general transfer function:

$$HF(z) = h_0 + h_1z^{-1} + h_2z^{-2} + \dots + h_nz^{-n} \quad \text{Equation 1}$$

where the number of taps in the filter = $n + 1$.

The transfer function for the IIR part of Z and B filters:

$$HI(z) = \frac{1}{1 - h_{(n+1)}z^{-1}} \quad \text{Equation 2}$$

The transfer function of the IIR part of the R filter is:

$$HI(z) = \frac{1 - z^{-1}}{1 - h_{(n+1)}z^{-1}} \quad \text{Equation 3}$$

The values of the user-defined coefficients (h_i) are assigned via the MPI. Each of the coefficients (h_i) is defined in the following general equation:

$$h_i = B_12^{-M_1} + B_22^{-M_2} + \dots + B_N2^{-M_N} \quad \text{Equation 4}$$

where:

M_i = the number of shifts = $M_i \leq M_i + 1$

B_i = sign = ± 1

N = number of CSD coefficients.

h_i in Equation 4 represents a decimal number, broken down into a sum of successive values of:

- 1) ± 1.0 multiplied by 2^{-0} , or 2^{-1} , or 2^{-2} ... 2^{-7} ...
- 2) ± 1.0 multiplied by 1, or 1/2, or 1/4 ... 1/128 ...

The limit on the negative powers of 2 is determined by the length of the registers in the ALU.

The coefficient h_i in Equation 4 is a value made up of N binary 1s in a binary register where the left part represents whole numbers, the right part decimal fractions, and a decimal point separates them. The first binary 1 is shifted M_1 bits to the right of the decimal point; the second binary 1 is shifted M_2 bits to the right of the decimal point; the third binary 1 is shifted M_3 bits to the right of the decimal point, and so on.

When M_1 is 0, the value is a binary 1 in front of the decimal point, that is, no shift. If M_2 is also 0, the result is another binary 1 in front of the decimal point, giving a total value of binary 10 in front of the decimal point (i.e., a decimal value of 2.0). The value of N , therefore, determines the range of values the coefficient h_i can take (e.g., if $N = 3$ the maximum and minimum values are ± 3 , and if $N = 4$ the values are between ± 4).

Detailed Description of QLSLAC Device Coefficients

The CSD coding scheme in the QLSLAC device uses a value called m_i , where m_1 represents the distance shifted right of the decimal point for the first binary 1. m_2 represents the distance shifted to the right of the previous binary 1, and m_3 represents the number of shifts to the right of the second binary 1. Note that the range of values determined by N is unchanged. Equation 4 is now modified (in the case of $N = 4$) to:

$$h_i = B_12^{-m_1} + B_22^{-m_2} + B_32^{-m_3} + B_42^{-m_4} \quad \text{Equation 5}$$

$$h_i = C_1 \cdot 2^{-m_1} + C_1 \cdot C_2 \cdot 2^{-(m_1 + m_2)} + C_1 \cdot C_2 \cdot C_3 \cdot 2^{-(m_1 + m_2 + m_3)} + C_1 \cdot C_2 \cdot C_3 \cdot C_4 \cdot 2^{-(m_1 + m_2 + m_3 + m_4)}$$

Equation 6

$$h_i = C_1 \cdot 2^{-m_1} \{1 + C_2 \cdot 2^{-m_2} [1 + C_3 \cdot 2^{-m_3} (1 + C_4 \cdot 2^{-m_4})]\}$$

Equation 7

where:

$M_1 = m_1$

$B_1 = C_1$

$M_2 = m_1 + m_2$

$B_2 = C_1 \cdot C_2$

$$M_3 = m1 + m2 + m3 \quad B_3 = C1 \cdot C2 \cdot C3$$

$$M_4 = m1 + m2 + m3 + m4 \quad B_4 = C1 \cdot C2 \cdot C3 \cdot C4$$

In the QLSLAC device, a coefficient, h_i , consists of N CSD coefficients, each being made up of 4 bits and formatted as $C_{xy}m_{xy}$, where C_{xy} is 1 bit (MSB) and m_{xy} is 3 bits. Each CSD coefficient is broken down as follows:

C_{xy} is the sign bit (0 = positive, 1 = negative).

m_{xy} is the 3-bit shift code. It is encoded as a binary number as follows:

000: 0 shifts

001: 1 shifts

010: 2 shifts

011: 3 shifts

100: 4 shifts

101: 5 shifts

110: 6 shifts

111: 7 shifts

y is the coefficient number (the i in h_i).

x is the position of this CSD coefficient within the h_i coefficient. The most significant binary 1 is represented by $x = 1$. The next most significant binary 1 is represented by $x = 2$, and so on.

Thus, C13 m13 represents the sign and the relative shift position for the first (most significant) binary 1 in the 4th (h_3) coefficient.

The number of CSD coefficients, N, is limited to 4 in the GR, GX, R, X, and Z filters; 4 in the IIR part of the B filter; 3 in the FIR part of the B filter; and 2 in the post-gain factor of the Z-IIR filter. The GX filter coefficient equation is slightly different from the other filters.

$$h_{iGX} = 1 + h_i \quad \text{Equation 8}$$

Please refer to the *Summary of MPI Commands* on [page 39](#) for complete details on programming the coefficients.

User Test States and Operating Conditions

The QLSLAC device supports testing by providing test states and special operating conditions as shown in Figure 21 (see Operating Conditions register).

Cutoff Transmit Path (CTP): When CTP = 1, DX and \overline{TSC} are High impedance and the transmit time slot does not exist. This state takes precedence over the TSA Loopback (TLB) and Full Digital Loopback (FDL) states.

Cutoff Receive Path (CRP): When CRP = 1, the receive signal is forced to 0 just ahead of the low pass filter (LPF) block. This state also blocks Full Digital Loopback (FDL), the 1 kHz receive tone, and the B-filter path.

High Pass Filter Disable (HPF): When HPF = 1, all of the High pass and notch filters in the transmit path are disabled.

Lower Receive Gain (LRG): When LRG = 1, an extra 6.02 dB of loss is inserted into the receive path.

Arm Transmit Interrupt (ATI) and Read Transmit PCM Data: The read transmit PCM data command, Command CDh, can be used to read transmit PCM data through the microprocessor interface. If the ATI bit is set, an interrupt will be generated whenever new transmit data appears in the channel and will be cleared when the data is read. When combined with Tone Generation and Loopback states, this allows the microprocessor to test channel integrity.

TSA Loopback (TLB): When TLB = 1, data from the TSA receive path is looped back to the TSA transmit path. Any other data in the transmit path is overwritten.

Full Digital Loopback (FDL): When FDL = 1, the VOUT output is turned off and the analog output voltage is routed to the input of the transmit path, replacing the voltage from VIN. The AISN path is temporarily turned off. This test mode can also be entered by writing the code 10000 into the AISN register.

1 kHz Receive Tone (TON): When TON = 1, a 1 kHz digital mW is injected into the receive path, replacing any receive signal from the TSA.

A-Law and μ -Law Companding

Table [Table 7](#) and Table [Table 8](#) show the companding definitions used for A-law and μ -law PCM encoding.

Table 7. A-Law: Positive Input Values

1	2	3	4	5	6	7	8
Segment Number	# Intervals x Interval Size	Value at Segment End Points	Decision Value Number n	Decision Value x_n (See Note 1)	Character Signal pre Inversion of Even Bits	Quantized Value (at Decoder Output) y_n	Decoder Output Value No.
					Bit No. 1 2 3 4 5 6 7 8		
7	16 x 128	4096	(128)	(4096)	-----	4032	128
			127	3968	1 1 1 1 1 1 1 1		
6	16 x 64	2048	113	2176	See Note 2	2112	113
			112	2048	1 1 1 1 0 0 0 0		
5	16 x 32	1024	97	1088	See Note 2	1056	97
			96	1024	1 1 1 0 0 0 0 0		
4	16 x 16	256	65	272	See Note 2	264	65
			64	256	1 1 0 0 0 0 0 0		
3	16 x 8	128	49	136	See Note 2	132	49
			48	128	1 0 1 1 0 0 0 0		
2	16 x 4	64	33	68	See Note 2	66	33
			32	64	1 0 1 0 0 0 0 0		
1	32 x 2	0	1	2	See Note 2	1	1
			0	0	1 0 0 0 0 0 0 0		

Notes:

- 4096 normalized value units correspond to $TMAX = 3.14 \text{ dBm0}$.
- The character signals are obtained by inverting the even bits of the signals of column 6. Before this inversion, the character signal corresponding to positive input values between two successive decision values numbered n and $n+1$ (see column 4) is $128+n$, expressed as a binary number.
- The value at the decoder output is $y_n = \frac{x_{n-1} + x_n}{2}$, for $n = 1, \dots, 127, 128$.
- x_{128} is a virtual decision value.
- Bit 1 is a 0 for negative input values.

Table 8. μ -Law: Positive Input Values

1 Segment Number	2 # Intervals x Interval Size	3 Value at Segment End Points	4 Decision Value Number n	5 Decision Value x_n (See Note 1)	6 Character Signal pre Inversion of Even Bits	7 Quantized Value (at Decoder Output) y_n	8 Decoder Output Value No.
					Bit No. 1 2 3 4 5 6 7 8		
8	16 x 256	8159	(128)	(8159)	-----	8031	127
			127	7903	1 0 0 0 0 0 0 0		
7	16 x 128	4063	113	4319	See Note 2	4191	112
			112	4063	1 0 0 0 1 1 1 1		
6	16 x 64	2015	97	2143	See Note 2	2079	96
			96	2015	1 0 0 1 1 1 1 1		
5	16 x 32	991	81	1055	See Note 2	1023	80
			80	991	1 0 1 0 1 1 1 1		
4	16 x 16	479	65	511	See Note 2	495	64
			64	479	1 0 1 1 1 1 1 1		
3	16 x 8	223	49	239	See Note 2	231	48
			48	223	1 1 0 0 1 1 1 1		
2	16 x 4	95	33	103	See Note 2	99	32
			32	95	1 1 0 1 1 1 1 1		
1	15 x 2	31	17	35	See Note 2	33	16
			16	31	1 1 1 0 1 1 1 1		
↓	1 x 1	31	2	3	See Note 2	2	1
			1	1	1 1 1 1 1 1 1 0		
			0	0	1 1 1 1 1 1 1 1	0	0

Notes:

- 8159 normalized value units correspond to $TMAX = 3.17$ dBm0.
- The character signal corresponding to positive input values between two successive decision values numbered n and $n+1$ (see column 4) is $255-n$, expressed as a binary number.
- The value at the decoder is $y_0 = x_0 = 0$ for $n = 0$, and $y_n = \frac{x_{n+1} + x_n}{2}$, for $n = 1, 2, \dots, 127$.
- x_{128} is a virtual decision value.
- Bit 1 is a 0 for negative input values.

APPLICATIONS

The QLSLAC device performs a programmable codec/filter function for four telephone lines. It interfaces to the telephone lines through a Legerity SLIC device or a transformer with external buffering. The QLSLAC device provides latched digital I/O to control and monitor four SLIC devices and provides access to time-critical information, such as off/on-hook and ring trip, for all four channels via a single read operation. When various country or transmission requirements must be met, the QLSLAC device enables a single SLIC device design for multiple applications. The line characteristics (such as apparent impedance, attenuation, and hybrid balance) can be modified by programming each QLSLAC device channel's coefficients to meet desired performance. The QLSLAC device may require an external buffer to drive transformer SLIC devices.

Connection to a PCM back plane is implemented by means of a simple buffer chip. Several QLSLAC devices can be tied together in one bus interfacing the back plane through a single buffer. An intelligent bus interface chip is not required because each QLSLAC device provides its own buffer control (TSXA/B). The QLSLAC device is controlled through the microprocessor interface, either by a microprocessor on the line card or by a central processor.

Controlling the SLIC Device

The Le58QL021 QLSLAC device has five TTL-compatible I/O pins (CD1, CD2, C3 to C5) for each channel. The Le58QL031 QLSLAC device has only CD1 and CD2 available. The outputs are programmed using Command 52h, and the status is read back using Command 53h. CD1 and CD2 for all four channels can be read back using Command 4D/4Fh. The direction of the I/O pins (input or output) is specified by programming the SLIC device I/O direction register (Command 54/55h).

Calculating Coefficients with WinSLAC Software

The WinSLAC software is a program that models the QLSLAC device, the line conditions, the SLIC device, and the line card components to obtain the coefficients of the programmable filters of the QLSLAC device and some of the transmission performance plots.

The following parameters relating to the desired line conditions and the components/circuits used in the line card are to be provided as input to the program:

1. Line impedance or the balance impedance of the line is specified by the local telephone system.
2. Desired two-wire impedance that is to appear at the line card terminals of the exchange.
3. Tabular data for templates describing the frequency response and attenuation distortion of the design.
4. Relative analog signal levels for both the transmit and receive two-wire signals.
5. Component values and SLIC device selection for the analog portion of the line circuits.
6. Two-wire return loss template is usually specified by the local telephone system.
7. Four-wire return loss template is usually specified by the local telephone system.

The output from the WinSLAC program includes the coefficients of the GR, GX, Z, R, X, and B filters as well as transmission performance plots of two-wire return loss, receive and transmit path frequency responses, and four-wire return loss.

The software supports the use of the Legerity SLIC devices or allows entry of a SPICE netlist describing the behavior of any type of SLIC device circuit.

APPLICATION CIRCUIT

Figure 26. Le7920 SLIC/QLSLAC Device Application Circuit

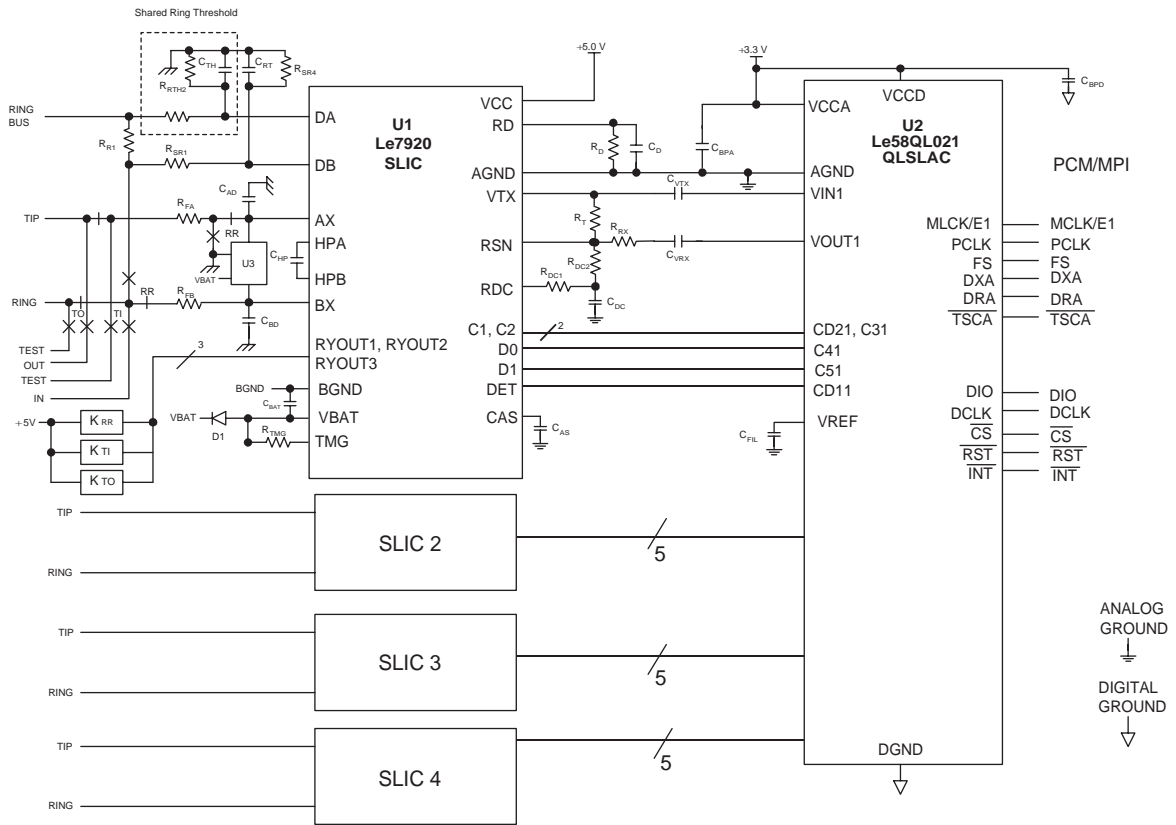

LINE CARD PARTS LIST

The following list defines the parts and part values required to meet target specification limits for one channel.

Item	Quantity	Type	Value	Tol.	Rating	Comments
C _{BP1A}	1	Capacitor	0.1 μF	20%	10 V	Bypass capacitor
C _{BPD}	1	Capacitor	0.1 μF	20%	10 V	Bypass capacitor
C _{FIL}	1	Capacitor	0.1 μF	20%	10 V	Bypass capacitor
C _{VTX}	1	Capacitor	0.1 μF	20%	10 V	Coupling capacitor
R _{RX}	1	Resistor	57.6 kΩ	1%	0.01 W	
C _{VRX}	1	Capacitor	0.15 μF	20%	10 V	
R _T	1	Resistor	178 kΩ	1%	0.01 W	
R _{FA}	1	Fuse resistor	50 Ω	See Note		
R _{FB}	1	Fuse resistor	50 Ω			

Note:

For all other components, please refer to the Le7920 Data Sheet, document ID #080146.

PHYSICAL DIMENSIONS

32-Pin PLCC

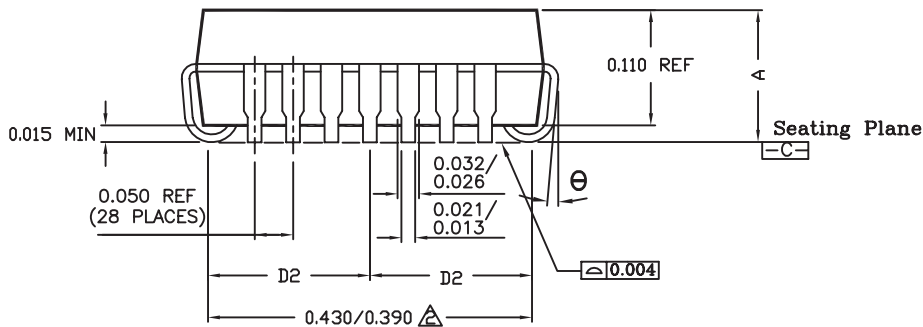
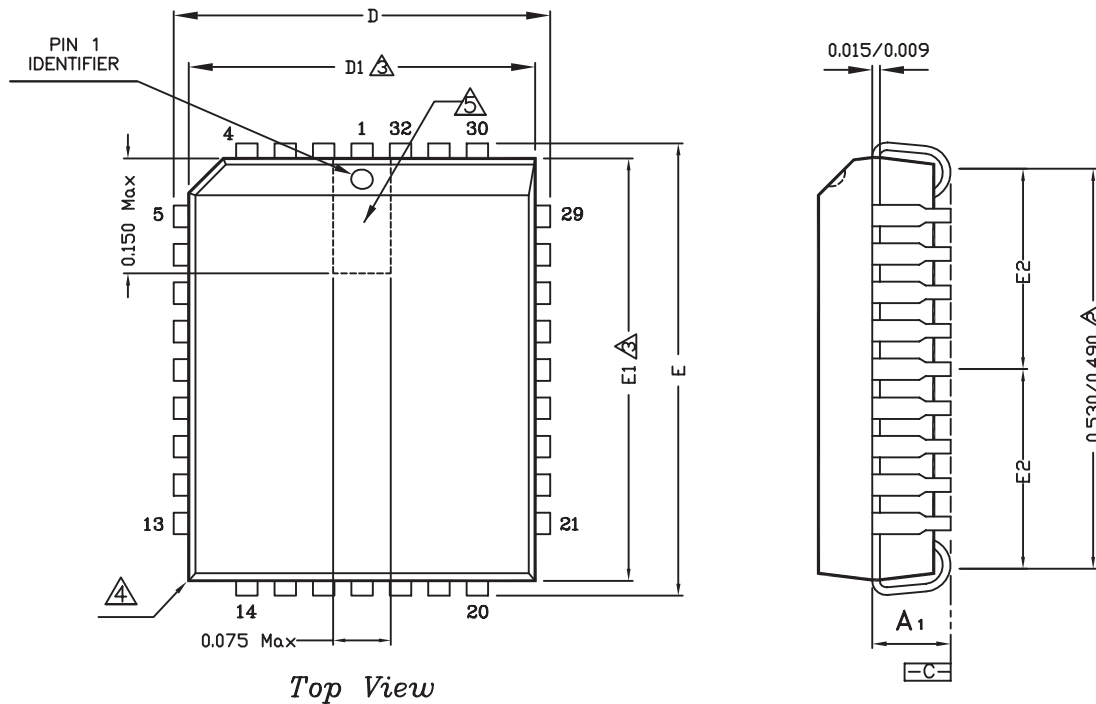

NOTE :

1. DIMENSIONING AND TOLERANCING CONFORM TO ASME Y14,5M-1994.
- △ TO BE MEASURED AT SEATING PLANE [C] CONTACT POINT.
- △ DIMENSIONS D1 AND E1 DO NOT INCLUDE MOLD PROTRUSION. ALLOWABLE MOLD PROTRUSION IS 0.010 IN PER SIDE. DIMENSIONS D, AND E, INCLUDE MOLD MISMATCH AND DETERMINED AT THE PARTING LINE; THAT IS D1 AND E1 ARE MEASURED AT THE EXTREME MATERIAL CONDITION AT THE UPPER OR LOWER PARTING LINE.
- △ EXACT SHAPE OF THIS FEATURE IS OPTIONAL.
- △ DETAILS OF PIN 1 IDENTIFIER ARE OPTIONAL BUT MUST BE LOCATED WITHIN THE ZONE INDICATED.
6. SUM OF DAM BAR PROTRUSIONS TO BE 0.007 MAX PER LEAD.
7. CONTROLLING DIMENSION : INCH.
8. REFERENCE DOCUMENT : JEDEC MS-016

Symbol	Dimension in inch		
	Min	Nom	Max
A	0.125	—	0.140
A1	0.075	0.090	0.095
D	0.485	0.490	0.495
D1	0.447	0.450	0.453
D2	0.205 REF		
E	0.585	0.590	0.595
E1	0.547	0.550	0.553
E2	0.255 REF		
θ	0°	—	10°

44-Pin PLCC

PLCC 044

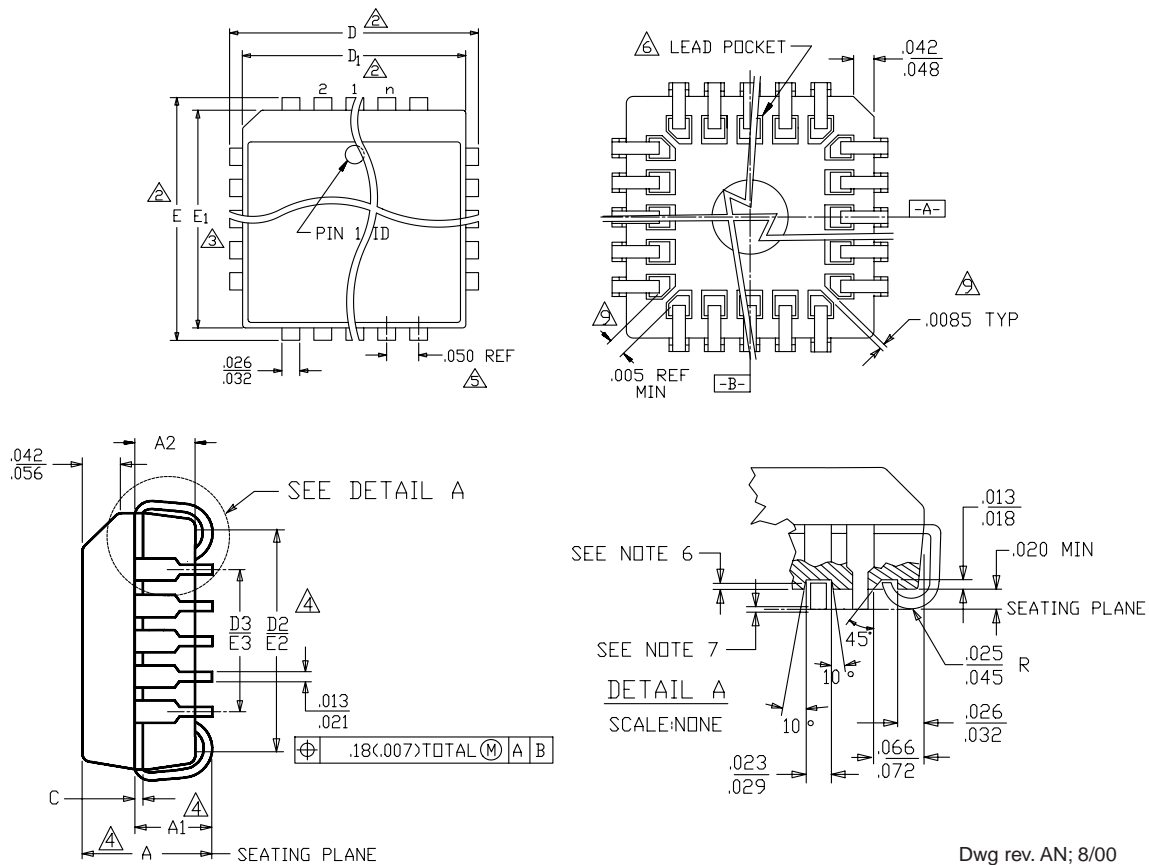

Dwg rev. AN; 8/00

PACKAGE	PLCC 044	
JEDEC	MS-018(A)AC	
SYMBOL	MIN	MAX
A	.165	.180
A1	.090	.120
A2	.062	.083
D	.685	.695
D1	.650	.656
D2	.590	.630
D3	.500	REF
E	.685	.695
E1	.650	.656
E2	.590	.630
E3	.500	REF
C	.009	.015

NOTES: (UNLESS OTHERWISE SPECIFIED)

- ALL DIMENSIONS ARE IN INCHES.
- DIMENSIONS "D" AND "E" ARE MEASURED FROM OUTERMOST POINT.
- DIMENSIONS D1 AND E1 DO NOT INCLUDE CORNER MOLD FLASH. ALLOWABLE CORNER MOLD FLASH IS .010 INCH.
- DIMENSIONS "A", "A1", "D2" AND "E2" ARE MEASURED AT THE POINTS OF CONTACT TO BASE PLANE.
- LEAD SPACING AS MEASURED FROM CENTERLINE TO CENTERLINE SHALL BE WITHIN $\pm .005$ INCH.
- J-LEAD TIPS SHOULD BE LOCATED INSIDE THE "POCKET".
- LEAD COPLANARITY SHALL BE WITHIN .004 INCH AS MEASURED FROM SEATING PLANE. COPLANARITY IS MEASURED PER AMD 06-500.
- LEAD TWEETZ SHALL BE WITHIN .0045 INCH ON EACH SIDE AS MEASURED FROM A VERTICAL FLAT PLANE. TWEETZ IS MEASURED PER AMD 06-500.
- LEAD POCKET MAY BE RECTANGULAR (AS SHOWN) OR OVAL. IF CORNER LEAD POCKETS ARE CONNECTED THEN 5 MILS MINIMUM CORNER LEAD SPACING IS REQUIRED.

44-Pin TQFP

TQFP 044

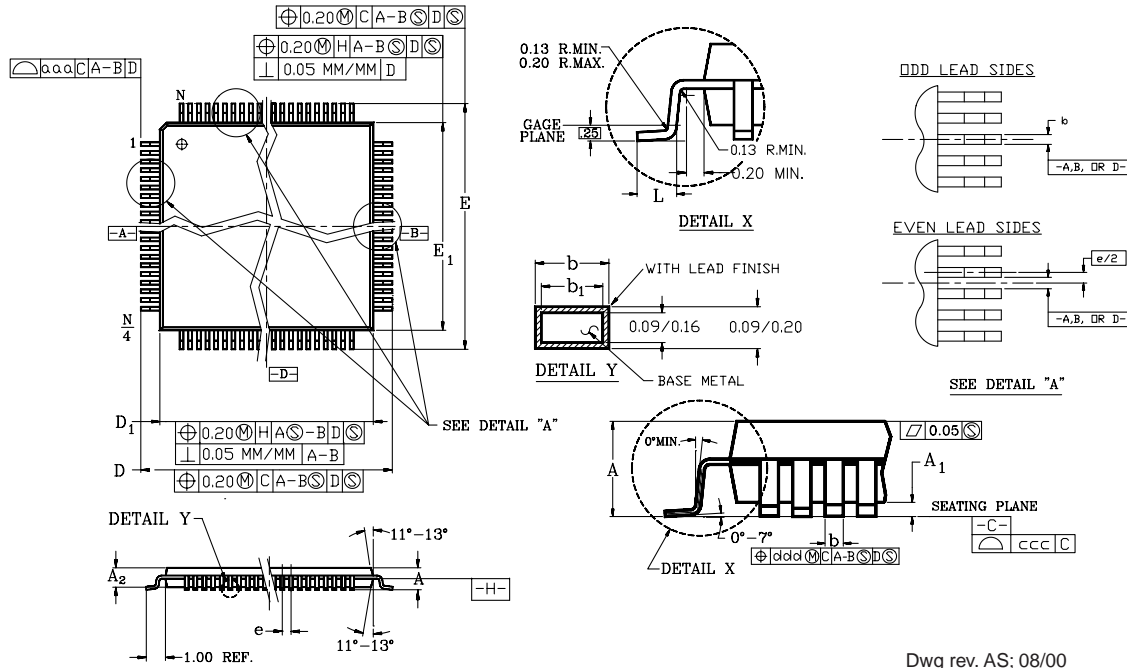

Dwg rev. AS; 08/00

PACKAGE	TQFP 044		
JEDEC	MS-026 (C) ACB		
SYMBOL	MIN	NOM	MAX
A	—	—	1.20
A1	0.05	--	0.15
A2	0.95	1.00	1.05
D	12.00 BSC		
D1	10.00 BSC		
E	12.00 BSC		
E1	10.00 BSC		
L	0.45	0.60	0.75
N	44		
e	0.80 BASIC		
b	0.30	0.37	0.45
b1	0.30	0.35	0.40
TOLERANCES OF FORM AND POSITION			
ccc	0.10		
ddd	0.20		
aaa	0.20		

NOTES:

- ALL DIMENSIONS AND TOLERANCES CONFORM TO ANSI Y14.5M-1982.
- DATUM PLANE ---H--- IS LOCATED AT THE MOLD PARTING LINE AND IS COINCIDENT WITH THE BOTTOM OF THE LEAD WHERE THE LEAD EXITS THE PLASTIC BODY.
- DIMENSIONS "D1" AND "E1" DO NOT INCLUDE MOLD PROTRUSION. ALLOWABLE PROTRUSION IS 0.254mm PER SIDE. DIMENSIONS "D1" AND "E1" INCLUDE MOLD MISMATCH AND ARE DETERMINED AT DATUM PLANE ---H--- .
- DIMENSION "B" DOES NOT INCLUDE DAMBAR PROTRUSION. ALLOWABLE DAMBAR PROTRUSION SHALL BE 0.08mm TOTAL IN EXCESS OF THE b DIMENSION AT MAXIMUM MATERIAL CONDITION. DAMBAR CAN NOT BE LOCATED ON THE LOWER RADIUS OR THE FOOT.
- CONTROLLING DIMENSIONS: MILLIMETER.
- DIMENSIONS "D" AND "E" ARE MEASURED FROM BOTH INNERMOST AND OUTERMOST POINTS.
- DEVIATION FROM LEAD-TIP TRUE POSITION SHALL BE WITHIN $\pm 0.076 \text{ MM}$. FOR PITCH $> 0.5 \text{ mm}$. AND WITHIN ± 0.04 FOR PITCH $\leq 0.5 \text{ mm}$.
- LEAD COPLANARITY SHALL BE WITHIN: (REFER TO 06-500)
1- 0.10 mm FOR DEVICES WITH LEAD PITCH OF 0.65-0.80 mm.
2- 0.076 mm FOR DEVICES WITH LEAD PITCH OF 0.50 mm.
COPLANARITY IS MEASURED PER SPECIFICATION 06-500.
- HALF SPAN (CENTER OF PACKAGE TO LEAD TIP) SHALL BE $15.30 \pm 0.165 \{ .602 \pm .0065 \}$
- "N" IS THE TOTAL NUMBER OF TERMINALS.
- THE TOP OF PACKAGE IS SMALLER THAN THE BOTTOM OF THE PACKAGE BY 0.15 MILLIMETERS.
- THIS OUTLINE CONFORMS TO JEDEC PUBLICATION 95 REGISTRATION MS-026.
- THE 160 LEAD IS A COMPLIANT DEPOPULATION OF THE 176 LEAD MS-026 VARIATION BGA.

REVISION HISTORY

Revision A1 to A2

- Changed titles for physical dimensions graphics to more industry-standard names

Revision A2 to B1

- Added information regarding the input attenuator gain (GIN) throughout document
- Made minor edits to the "Product Description" section
- Removed references to resistors R_{OUT1} and R_{OUT2} from "Application Circuit" and "Line card Parts List"

Revision B1 to C1

- Added a maximum VCC current limit of 0.5 A to the Absolute Maximum Ratings if the rise rate of VCC is greater than 0.4 V/ μ s
- Decreased the digital leakage allowed from 15 to 7 μ A
- Increased the standby power to 13 mW typical and 18 mW maximum
- In Transmission Characteristics, Second Harmonic Distortion, added GR=0 dB; added D-A in Description field
- Added a nominal spec on the chopper clock duty cycle
- Added a note warning the user of 81 ns phase jumps on CHCLK and E1 when the master clock is a multiple of 1.544 MHz
- Modified the power-up sequence
- At E1 Multiplex Operation, added "If EE1 is reset, MCLK/E1 is programmed as an input and should be connected to ground if it is not connected to a clock source"
- Clarified Interrupt section wording by adding a phrase
- At Reset States, when E1 Multiplex state is turned off, added "(E1 is Hi-Z)"

Revision C1 to D1

- Added green package OPNs to [Description, on page 1](#)
- Added [Package Assembly, on page 11](#)

Revision D1 to E1

- Added "Packing" column and Note 2 to [Ordering Information, on page 1](#)

Revision E1 to F1

- Modified GAISN specification in [Electrical Characteristics, on page 12](#).

The contents of this document are provided in connection with Legerity, Inc. products. Legerity makes no representations or warranties with respect to the accuracy or completeness of the contents of this publication and reserves the right to make changes to specifications and product descriptions at any time without notice. No license, whether express, implied, arising by estoppel or otherwise, to any intellectual property rights is granted by this publication. Except as set forth in Legerity's Standard Terms and Conditions of Sale, Legerity assumes no liability whatsoever, and disclaims any express or implied warranty, relating to its products including, but not limited to, the implied warranty of merchantability, fitness for a particular purpose, or infringement of any intellectual property right.

Legerity's products are not designed, intended, authorized or warranted for use as components in systems intended for surgical implant into the body, or in other applications intended to support or sustain life, or in any other application in which the failure of Legerity's product could create a situation where personal injury, death, or severe property or environmental damage may occur. Legerity reserves the right to discontinue or make changes to its products at any time without notice.

© 2006 Legerity, Inc.
All rights reserved.

Trademarks

Legerity, the Legerity logo and combinations thereof are registered trademarks, and BatteryDirect, ISLIC, ISLAC, PhonePort, QSLAC, QLSLAC, VoiceEdge, VoicePath, VoicePort, The "V" in VoIP and WinSLAC are trademarks of Legerity, Inc.

Other product names and marks used within this document are for identification purposes only and may be registered trademarks or trademarks of their respective companies.



4509 Freidrich Lane
Austin, Texas 78744-1812

Telephone: (512) 228-5400
Fax: (512) 228-5508
North America Toll Free: (800) 432-4009

To find the Legerity Sales Office nearest you, visit our website at:

<http://www.legerity.com/sales>

or email:

sales@legerity.com

To download or order data sheets, application notes, or evaluation tools, go to:

www.legerity.com/support

For all other technical inquiries, please contact Legerity Tech Support at:

techsupport@legerity.com

or call +1 512.228.5400.