

General Description

The AO7401 uses advanced trench technology to provide excellent $R_{DS(ON)}$, low gate charge, and operation with gate voltages as low as 2.5V, in the small SOT323 footprint. It can be used for a wide variety of applications, including load switching, low current inverters and low current DC-DC converters.

Features

$$V_{DS} (V) = -30V$$

$$I_D = -1.2A$$

$$R_{DS(ON)} < 150m\Omega (V_{GS} = -10V)$$

$$R_{DS(ON)} < 200m\Omega (V_{GS} = -4.5V)$$

$$R_{DS(ON)} < 280m\Omega (V_{GS} = -2.5V)$$

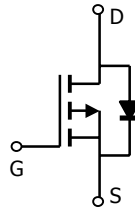
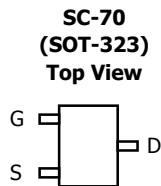

Absolute Maximum Ratings $T_A=25^\circ C$ unless otherwise noted

Parameter	Symbol	Maximum	Units
Drain-Source Voltage	V_{DS}	-30	V
Gate-Source Voltage	V_{GS}	± 12	V
Continuous Drain Current ^A	$T_A=25^\circ C$	-1.2	A
	$T_A=70^\circ C$	-1.0	
Pulsed Drain Current ^B	I_{DM}	-10	
Power Dissipation ^A	$T_A=25^\circ C$	0.35	W
	$T_A=70^\circ C$	0.22	
Junction and Storage Temperature Range	T_J, T_{STG}	-55 to 150	$^\circ C$

Thermal Characteristics

Parameter	Symbol	Typ	Max	Units
Maximum Junction-to-Ambient ^A	$R_{\theta JA}$	300	360	$^\circ C/W$
Maximum Junction-to-Ambient ^A		Steady-State	350	
Maximum Junction-to-Lead ^C	$R_{\theta JL}$	280	320	$^\circ C/W$

Electrical Characteristics ($T_J=25^\circ\text{C}$ unless otherwise noted)

Symbol	Parameter	Conditions	Min	Typ	Max	Units
STATIC PARAMETERS						
BV_{DSS}	Drain-Source Breakdown Voltage	$I_D=-250\mu\text{A}$, $V_{GS}=0\text{V}$	-30			V
I_{DSS}	Zero Gate Voltage Drain Current	$V_{DS}=-24\text{V}$, $V_{GS}=0\text{V}$ $T_J=55^\circ\text{C}$			-1 -5	μA
I_{GSS}	Gate-Body leakage current	$V_{DS}=0\text{V}$, $V_{GS}=\pm 12\text{V}$			± 100	nA
$V_{GS(th)}$	Gate Threshold Voltage	$V_{DS}=V_{GS}$, $I_D=-250\mu\text{A}$	-0.6	-1	-1.4	V
$I_{D(ON)}$	On state drain current	$V_{GS}=-4.5\text{V}$, $V_{DS}=-5\text{V}$	-10			A
$R_{DS(ON)}$	Static Drain-Source On-Resistance	$V_{GS}=-10\text{V}$, $I_D=-1.2\text{A}$ $T_J=125^\circ\text{C}$		122 173	150 220	$\text{m}\Omega$
		$V_{GS}=-4.5\text{V}$, $I_D=-1.2\text{A}$		147	200	$\text{m}\Omega$
		$V_{GS}=-2.5\text{V}$, $I_D=-1\text{A}$		207	280	$\text{m}\Omega$
g_{FS}	Forward Transconductance	$V_{DS}=-5\text{V}$, $I_D=-1.2\text{A}$	3	4.5		S
V_{SD}	Diode Forward Voltage	$I_S=-1\text{A}$, $V_{GS}=0\text{V}$		-0.85	-1	V
I_S	Maximum Body-Diode Continuous Current				-0.5	A
DYNAMIC PARAMETERS						
C_{iss}	Input Capacitance	$V_{GS}=0\text{V}$, $V_{DS}=-15\text{V}$, $f=1\text{MHz}$		409		pF
C_{oss}	Output Capacitance			55		pF
C_{rSS}	Reverse Transfer Capacitance			42		pF
R_g	Gate resistance	$V_{GS}=0\text{V}$, $V_{DS}=0\text{V}$, $f=1\text{MHz}$		12		Ω
SWITCHING PARAMETERS						
Q_g	Total Gate Charge	$V_{GS}=-4.5\text{V}$, $V_{DS}=-15\text{V}$, $I_D=-1\text{A}$		5.06		nC
Q_{gs}	Gate Source Charge			0.72		nC
Q_{gd}	Gate Drain Charge			1.58		nC
$t_{D(on)}$	Turn-On DelayTime	$V_{GS}=-10\text{V}$, $V_{DS}=-15\text{V}$, $R_L=15\Omega$, $R_{GEN}=3\Omega$		6.2		ns
t_r	Turn-On Rise Time			3.2		ns
$t_{D(off)}$	Turn-Off DelayTime			41.2		ns
t_f	Turn-Off Fall Time			14.5		ns
t_{rr}	Body Diode Reverse Recovery Time	$I_F=-1\text{A}$, $dI/dt=100\text{A}/\mu\text{s}$		13.2		ns
Q_{rr}	Body Diode Reverse Recovery Charge	$I_F=-1\text{A}$, $dI/dt=100\text{A}/\mu\text{s}$		5.4		nC

A: The value of $R_{\theta JA}$ is measured with the device mounted on 1in² FR-4 board with 2oz. Copper, in a still air environment with $T_A=25^\circ\text{C}$. The value in any a given application depends on the user's specific board design. The current rating is based on the $t \leq 10\text{s}$ thermal resistance rating.

B: Repetitive rating, pulse width limited by junction temperature.

C: The $R_{\theta JA}$ is the sum of the thermal impedance from junction to lead $R_{\theta JL}$ and lead to ambient.

D: The static characteristics in Figures 1 to 6, 12, 14 are obtained using 80 μs pulses, duty cycle 0.5% max.

E: These tests are performed with the device mounted on 1 in² FR-4 board with 2oz. Copper, in a still air environment with $T_A=25^\circ\text{C}$. The SOA curve provides a single pulse rating.

TYPICAL ELECTRICAL AND THERMAL CHARACTERISTICS

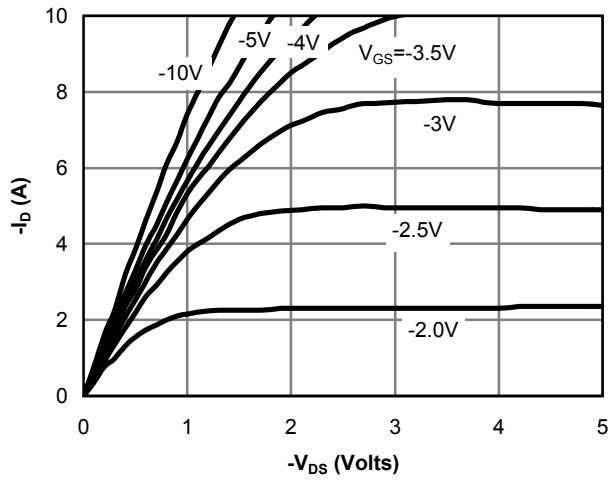

Fig 1: On-Region Characteristics

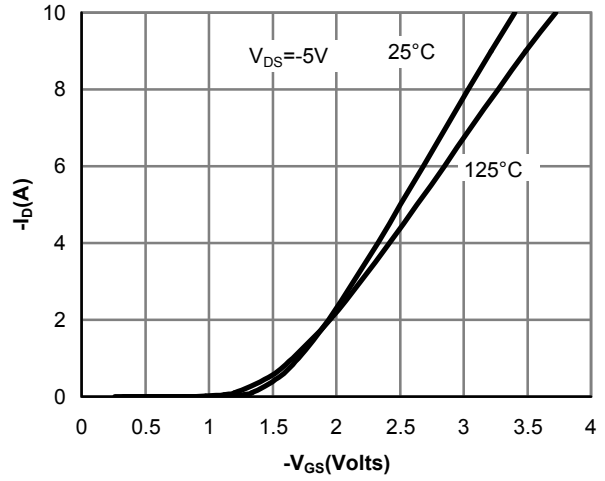

Figure 2: Transfer Characteristics

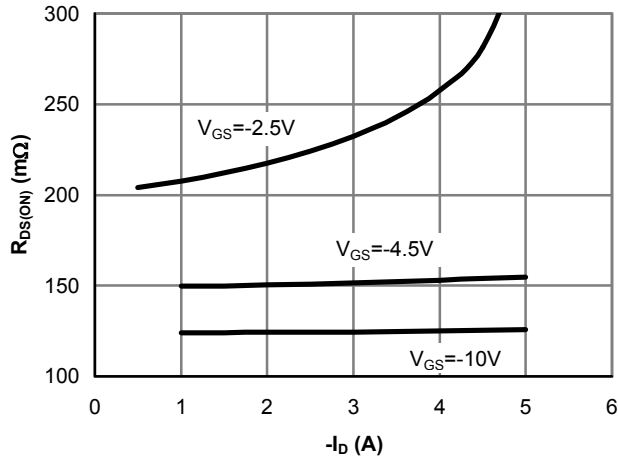

Figure 3: On-Resistance vs. Drain Current and Gate Voltage

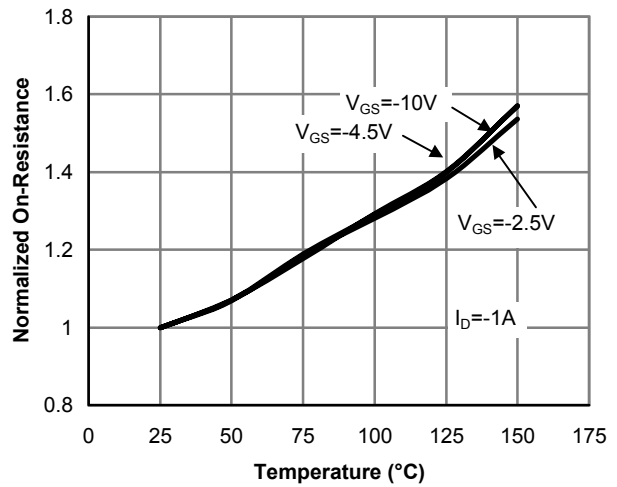

Figure 4: On-Resistance vs. Junction Temperature

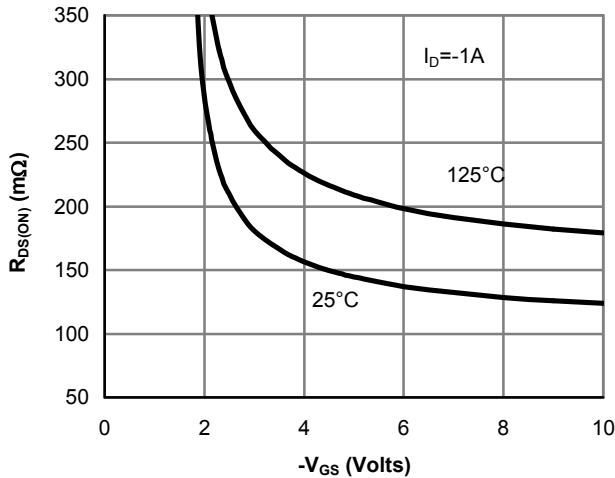

Figure 5: On-Resistance vs. Gate-Source Voltage

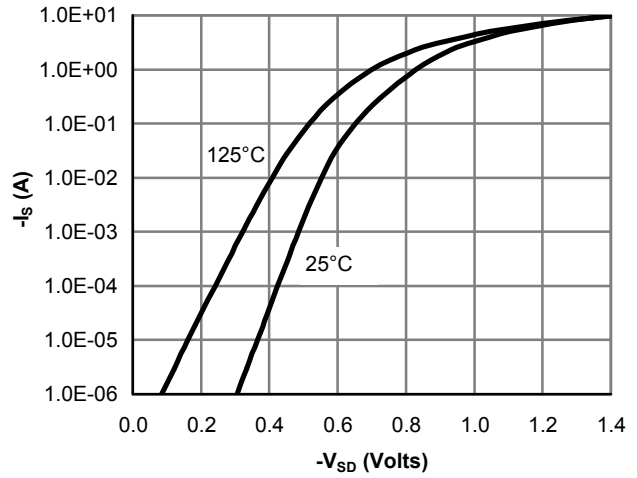

Figure 6: Body-Diode Characteristics

TYPICAL ELECTRICAL AND THERMAL CHARACTERISTICS

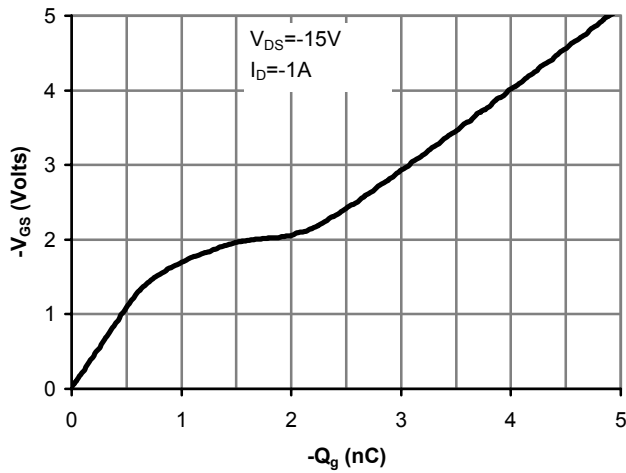

Figure 7: Gate-Charge Characteristics

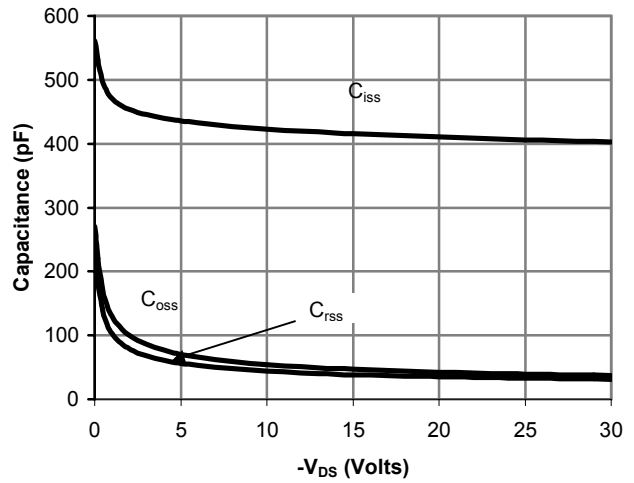

Figure 8: Capacitance Characteristics

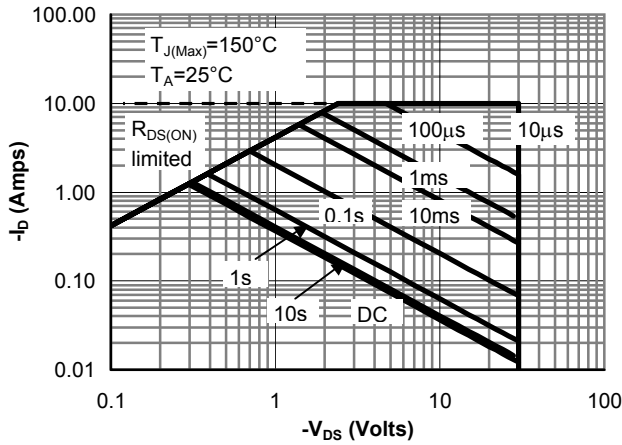

Figure 9: Maximum Forward Biased Safe Operating Area (Note E)

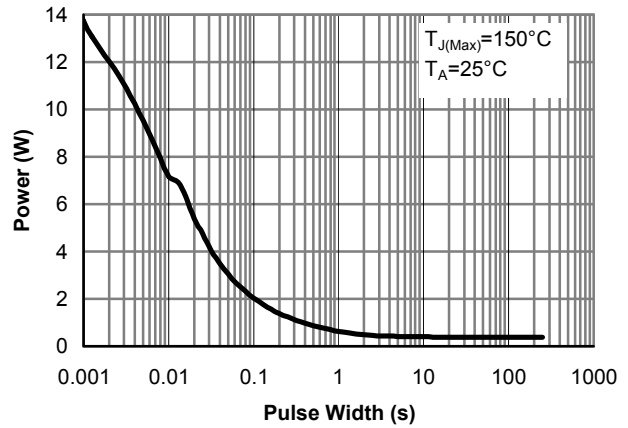

Figure 10: Single Pulse Power Rating Junction-to-Ambient (Note E)

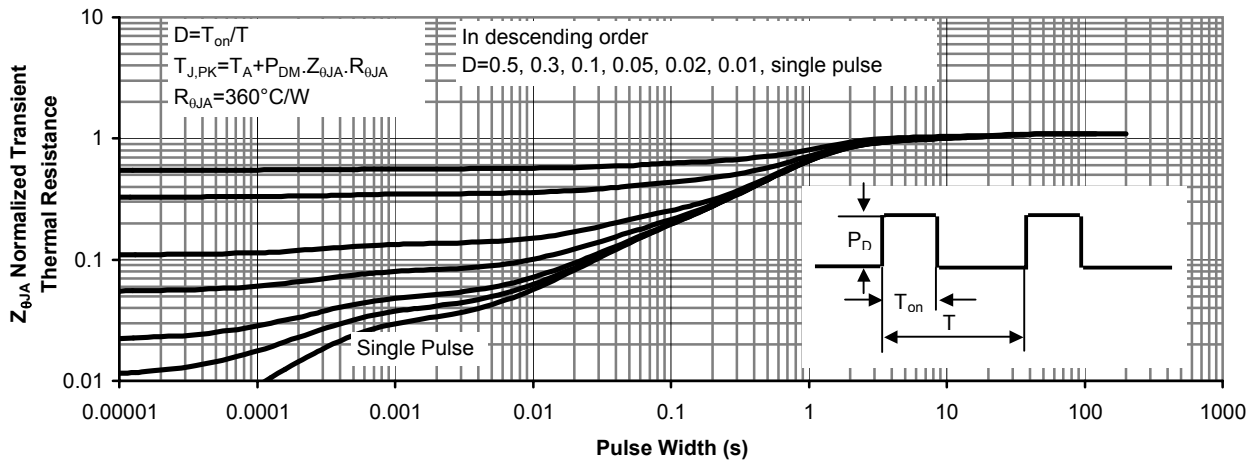
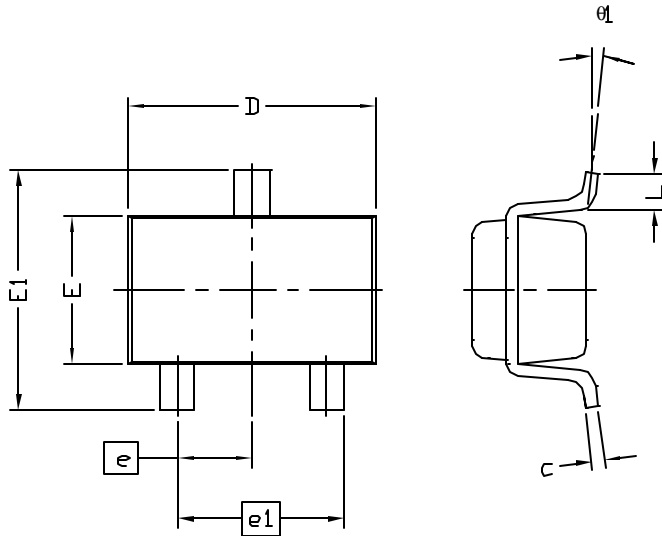

Figure 11: Normalized Maximum Transient Thermal Impedance

SC-70 3L Package Data



SYMBOLS	DIMENSIONS IN MILLIMETERS	
	MIN	MAX
A	0.90	1.10
A1	0.00	0.10
A2	0.90	1.00
b	0.25	0.40
C	0.10	0.20
D	1.80	2.20
E	1.15	1.35
E1	2.00	2.20
F	0.30	0.40
e	0.65 BSC	
e1	1.30 BSC	
L	0.10	0.30
θL	1°	8°

- NOTE:
 1. LEAD FINISH: 150 MICRONS (3.8 um) MIN.
 THICKNESS OF Tin/Lead (SOLDER) PLATED ON LEAD
 2. TOLERANCE ± 0.10 mm (4 mil) UNLESS OTHERWISE SPECIFIED
 3. COPLANARITY : 0.10 mm
 4. OTHER NAME OF THIS PACKAGE IS CALLED SOT-323

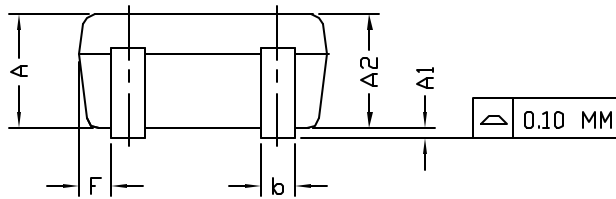

PACKAGE MARKING DESCRIPTION

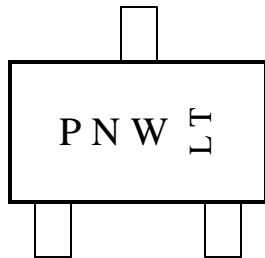

SC-70 3L PART NO. CODE

PART NO.	CODE
AO7401	1

- NOTE:
 P - PART NUMBER CODE.
 N - FOUNDRY AND ASSEMBLY LOCATION CODE
 W - YAER AND WEEK CODE.
 L T - ASSEMBLY LOT CODE.

RECOMMENDATION OF LAND PATTERN

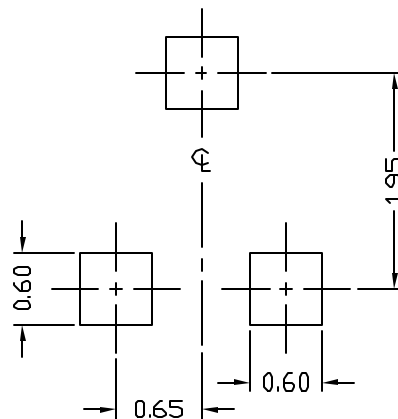

Rev. A

SC-70 3L Carrier Tape

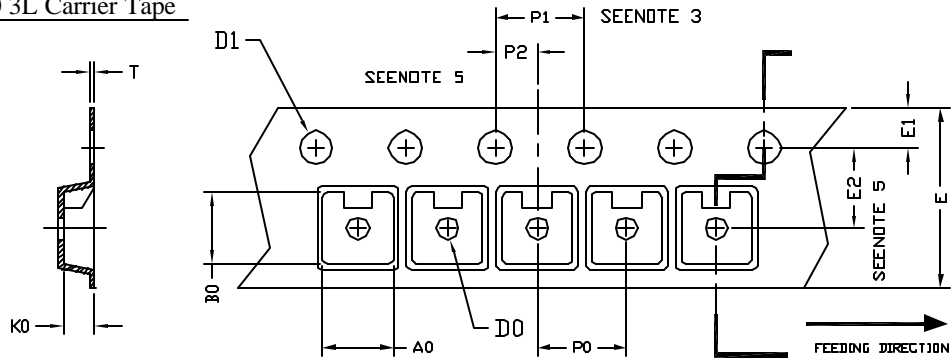

UNIT: MM

PACKAGE	A0	B0	K0	D0	D1	E	E1	E2	P0	P1	P2	T
SC-70, 3L (B mm)	2.40 ±0.10	2.40 ±0.10	1.19 ±0.10	1.00 MIN	1.55 ±0.05	8.00 ±0.30	1.75 ±0.10	3.50 ±0.05	4.00 ±0.10	4.00 ±0.10	2.00 ±0.05	0.25 ±0.05

SC-70 3L Reel

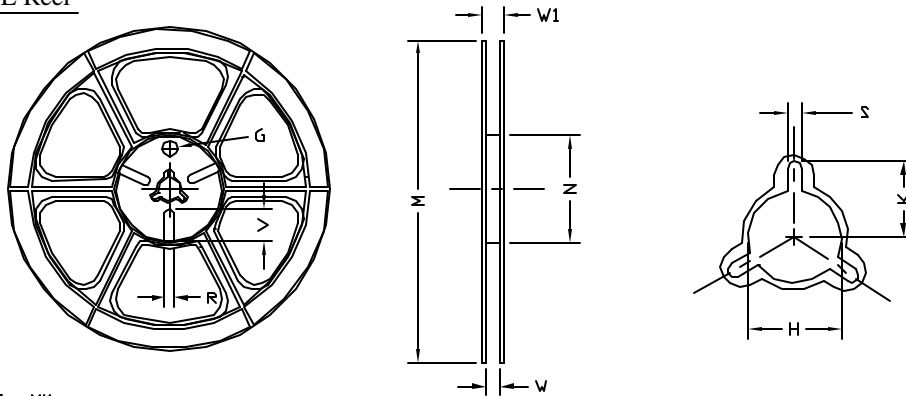

UNIT: MM

TAPE SIZE	REEL SIZE	M	N	W	W1	H	K	S	G	R	V
8 mm	φ180	φ180.00 ±0.50	φ60.50	9.00 ±0.30	11.40 ±1.00	φ13.00 +0.50 -0.20	10.60	2.00 ±0.50	φ9.00	5.00	18.00

SC-70 3L Tape

Leader / Trailer
& Orientation

