

Features

- Formerly J. W. Miller® model
- Shielded
- High Q value
- Inductance range: 0.1 μ H to 8200 μ H
- RoHS compliant*

Applications

- Filters
- Output chokes

9250A Series Molded Axial Inductor

Electrical Specifications

Bourns Part No.	Inductance		Q Min.	Test Frequency (MHz)	SRF (MHz) Min.	DCR (Ω) Max.	Idc (mA)	Isat (mA)
	(μ H)	Tol. (%)						
9250A-101-RC	0.10	± 10	50	25	250	0.025	1790	1790
9250A-121-RC	0.12	± 10	51	25	250	0.034	1530	1530
9250A-151-RC	0.15	± 10	51	25	250	0.037	1470	1470
9250A-181-RC	0.18	± 10	50	25	250	0.047	1300	1300
9250A-221-RC	0.22	± 10	49	25	250	0.067	1100	1100
9250A-271-RC	0.27	± 10	47	25	250	0.11	855	855
9250A-331-RC	0.33	± 10	46	25	250	0.13	780	780
9250A-391-RC	0.39	± 10	44	25	250	0.18	670	670
9250A-471-RC	0.47	± 10	44	25	235	0.25	565	565
9250A-561-RC	0.56	± 10	43	25	210	0.33	490	490
9250A-681-RC	0.68	± 10	42	25	190	0.45	420	420
9250A-821-RC	0.82	± 10	50	25	180	0.59	370	370
9250A-102-RC	1.0	± 10	40	25	140	0.07	1070	1070
9250A-122-RC	1.2	± 10	44	7.9	130	0.10	895	895
9250A-152-RC	1.5	± 10	44	7.9	115	0.12	815	815
9250A-182-RC	1.8	± 10	44	7.9	105	0.14	775	775
9250A-222-RC	2.2	± 10	44	7.9	100	0.19	650	650
9250A-272-RC	2.7	± 10	44	7.9	92	0.28	535	535
9250A-332-RC	3.3	± 10	44	7.9	85	0.35	480	480
9250A-392-RC	3.9	± 10	44	7.9	75	0.40	450	450
9250A-472-RC	4.7	± 10	44	7.9	70	0.55	380	380
9250A-562-RC	5.6	± 10	44	7.9	65	0.72	335	335
9250A-682-RC	6.8	± 10	50	7.9	55	1.02	280	280
9250A-822-RC	8.2	± 10	50	7.9	50	1.32	250	250
9250A-103-RC	10	± 10	50	7.9	46	1.62	220	220
9250A-123-RC	12	± 10	55	2.5	44	2.00	200	200
9250A-153-RC	15	± 10	45	2.5	49	0.80	315	250
9250A-183-RC	18	± 10	45	2.5	45	0.89	300	235
9250A-223-RC	22	± 10	45	2.5	41	0.96	290	220
9250A-273-RC	27	± 10	45	2.5	38	1.19	260	200
9250A-333-RC	33	± 10	45	2.5	34	1.37	240	190
9250A-393-RC	39	± 10	50	2.5	29	1.93	205	180
9250A-473-RC	47	± 10	50	2.5	27	2.11	195	175
9250A-563-RC	56	± 10	50	2.5	25	2.23	190	160
9250A-683-RC	68	± 10	50	2.5	21	2.70	170	150
9250A-823-RC	82	± 10	50	2.5	10.5	2.44	180	140
9250A-104-RC	100	± 10	50	2.5	10	3.12	160	120
9250A-124-RC	120	± 10	55	0.79	9.7	3.6	150	95
9250A-154-RC	150	± 10	55	0.79	8.5	4.1	140	90
9250A-184-RC	180	± 10	55	0.79	8.0	4.4	135	85
9250A-224-RC	220	± 10	55	0.79	7.5	5.0	125	80
9250A-274-RC	270	± 10	55	0.79	7.0	5.8	115	70
9250A-334-RC	330	± 10	55	0.79	6.5	6.4	110	65
9250A-394-RC	390	± 10	60	0.79	6.2	7.4	105	60
9250A-474-RC	470	± 10	60	0.79	5.7	9.5	92	58
9250A-564-RC	560	± 10	60	0.79	4.7	10.5	90	55
9250A-684-RC	680	± 10	60	0.79	4.5	11.8	80	50
9250A-824-RC	820	± 10	60	0.79	4.2	13.0	80	45

General Specifications

Temperature Rise 35 °C at Idc Rated Current
 Inductance drop 5 % typical at Isat
 Operating Temperature -55 °C to +125 °C
 Storage Temperature -55 °C to +125 °C
 Dielectric Strength 1000 Vrms

Materials

Core Ferrite
 Wire Enameled copper
 Terminal Coating Sn
 Packaging
 Standard 1000 pcs. per bag
 Optional 2500 pcs. per 12-inch reel

How to Order

9250A - 102 - - RC

Model _____
 Value Code _____
 (See table)
 Packaging Code _____
 Blank = 1000 pcs./bag
 TR = 2500 pcs./12-inch reel
 Compliance Code _____
 RC = RoHS compliant*

Examples:
 • 9250A-151-RC = 0.15 μ H packaged 1000 pcs./bag.
 • 9250A-681-TR-RC = 0.68 μ H packaged 2500 pcs./12-inch reel.

Electrical Schematic

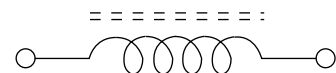

Electrical specifications continued on page 2.

*RoHS Directive 2002/95/EC Jan. 27, 2003 including annex and RoHS Recast 2011/65/EU June 8, 2011. Specifications are subject to change without notice.

The device characteristics and parameters in this data sheet can and do vary in different applications and actual device performance may vary over time. Users should verify actual device performance in their specific applications.

9250A Series Molded Axial Inductor

BOURNS®

Electrical Specifications (Continued)

Bourns Part No.	Inductance		Q Min.	Test Frequency (MHz)	SRF (MHz) Min.	DCR (Ω) Max.	Idc (mA)	Isat (mA)
	(μH)	Tol. (%)						
9250A-105-RC	1000	±10	60	0.79	3.8	17.5	70	40
9250A-125-RC	1200	±10	45	0.25	1.5	22.1	60	35
9250A-155-RC	1500	±10	45	0.25	1.2	26.5	55	33
9250A-185-RC	1800	±10	45	0.25	1.0	29.9	50	30
9250A-225-RC	2200	±10	45	0.25	0.97	33.8	50	27
9250A-275-RC	2700	±10	45	0.25	0.92	47.3	40	25
9250A-335-RC	3300	±10	45	0.25	0.84	53.0	40	22
9250A-395-RC	3900	±10	45	0.25	0.8	73.8	35	20
9250A-475-RC	4700	±10	45	0.25	0.74	81.6	31	19
9250A-565-RC	5600	±10	44	0.25	0.73	98.9	28	17
9250A-685-RC	6800	±10	40	0.25	0.66	111	27	16
9250A-825-RC	8200	±10	40	0.25	0.54	119	26	15

Product Dimensions

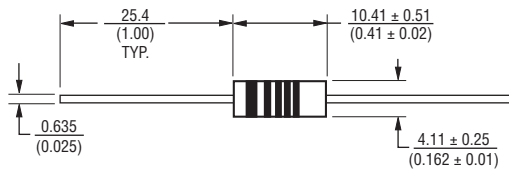

DIMENSIONS: $\frac{\text{MM}}{\text{(INCHES)}}$

Typ. Part Marking - MIL-STD Color Code

Color	1st & 2nd Significant Figure or Decimal Point	Multiplier	Tolerance
Black	0	1	
Brown	1	10	
Red	2	100	
Orange	3	1000	
Yellow	4		
Green	5		
Blue	6		
Violet	7		
Gray	8		
White	9		
Silver			± 10 %
Gold	Decimal Point		± 5 %

Example for L value less than 10 μH
6.8 μH, ±10 %

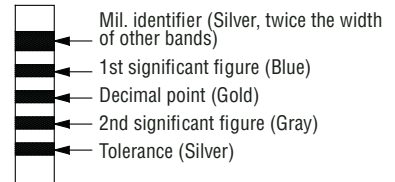

Example for L value 10 μH and higher
270 μH, ±5 %

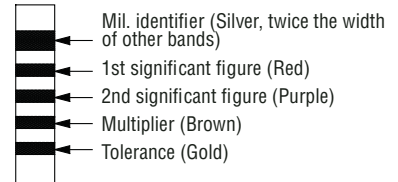

9250A Series Molded Axial Inductor

BOURNS®

Tape and Reel Packaging Specifications

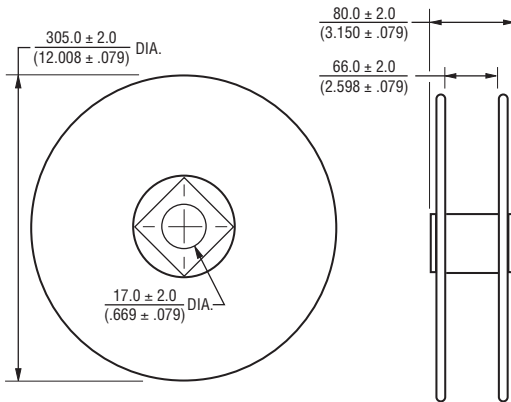

DIMENSIONS: $\frac{\text{MM}}{\text{(INCHES)}}$

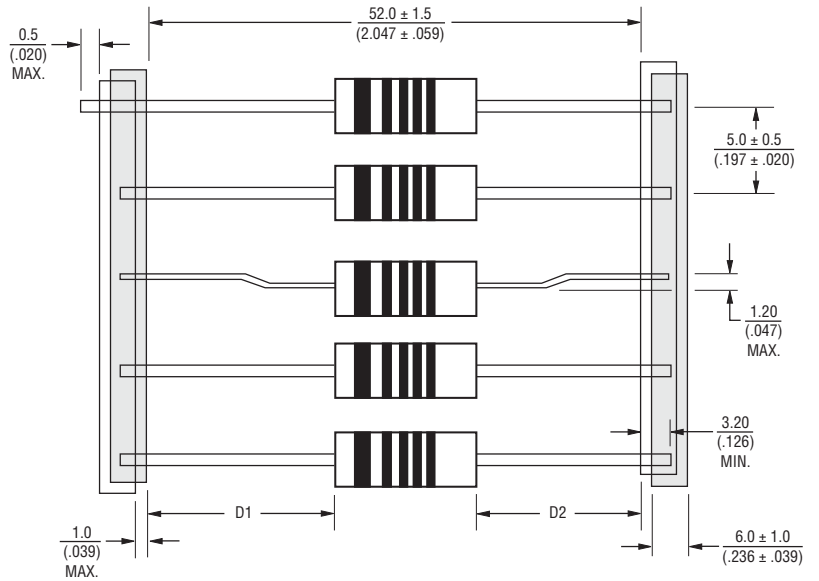

NOTE: THE DIFFERENCE BETWEEN D1 AND D2 SHOULD NOT EXCEED 1.0 (.039).

REV. 05/13

Specifications are subject to change without notice.
 The device characteristics and parameters in this data sheet can and do vary in different applications and actual device performance may vary over time.
 Users should verify actual device performance in their specific applications.