

2.4 GHz 1W MMIC

FEATURES

- P₋₁ dB: 31 dBm
- Small Signal Gain: 24 dB
- Power Added Efficiency: 30 %
- IP3: 39 dBm
- Bias Condition: 600 mA @ 5 V

PHOTO ENLARGEMENT



DESCRIPTION

The TC3133 is a 2 stage PHEMT MMIC power amplifier. It is designed for use in low cost and high volume 2.4-2.5 GHz ISM band applications. The MMIC provides a typical gain of 24 dB and saturation power of more than 31 dBm. Typical bias condition is 5V at 600 mA. The MMIC is packaged in a standard SO-8 power package. The copper based carrier of the package allows direct soldering of the device to the PCB for proper heat sinking. The input and output matching of the MMIC require external components.

ELECTRICAL SPECIFICATIONS (Ta = 25 °C)

SYMBOL	DESCRIPTION	MIN	TYP	MAX	UNITS
FREQ	Frequency Range	2.4		2.5	GHz
SSG	Small Signal Gain	22	24		dB
P₋₁ dB	Output Power at 1 dB Gain Compression	30	31		dBm
P₋₃ dB	Output Power at 3 dB Gain Compression	31	32		dBm
IP3	Third Order Intercept Point	37	39		dBm
VSWR, IN	Input VSWR		2:1		-
VDD	Supply Voltage		5		Volt
Vg	Gate Voltage	-0.6	-1.2	-2	Volt
IDD	Current Supply Without RF		600		mA
IDP₋₁	Current Supply @ Pout = P ₋₁ dB		800		mA
η_a	Power Added Efficiency		30		%

TEST CIRCUITS

Evaluation Board Schematic

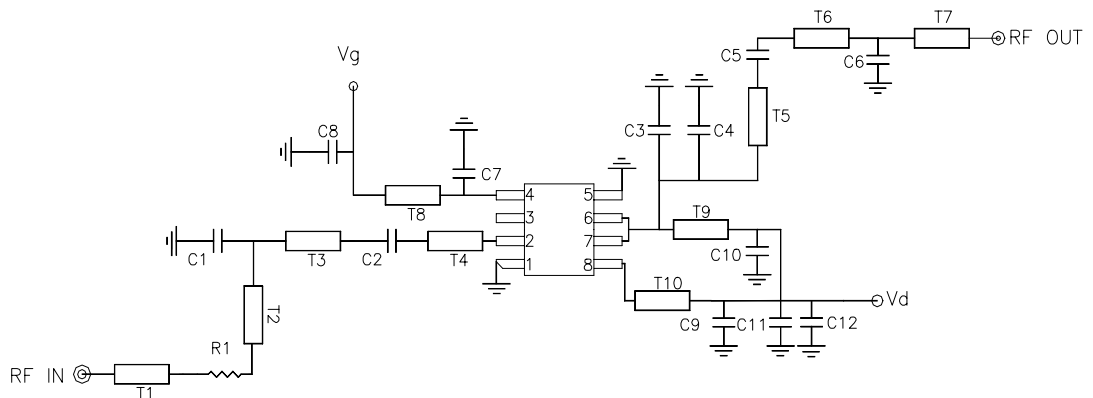
EVALUATION BOARD

PCB Material: FR4
 ER = 4.6
 Thickness = 31 mil
 Unit: mil

* DXF file of the PCB can be downloaded from our web-site at www.transcominc.com.tw

* Application Notes:
 For better heat sinking and grounding, it's recommended to have the via holes beneath TC3133 filled with solder and have two screws installed on required heat sink plate besides TC3133 on the PCB area.

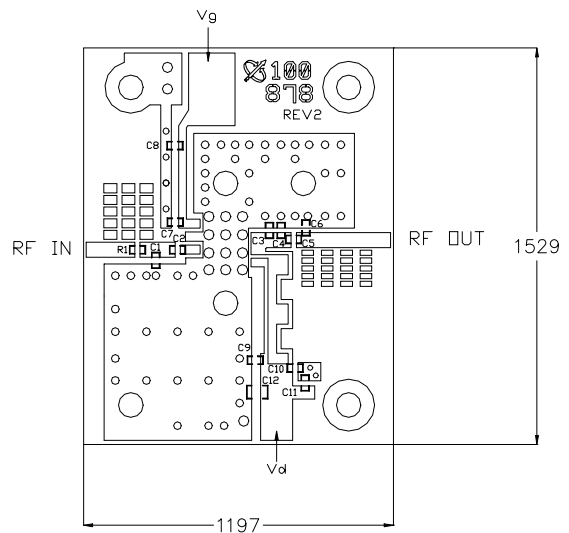

Evaluation Board Parts List

Part Type	Reference Designator	Description	Manufacturer	Part Number
Capacitor	C1, C4, C6	0.75 pF 0603	Murata	GRM39C0GR75C50V
Capacitor	C2, C5	2 pF 0603	Murata	GRM39C0G020C50V
Capacitor	C3	1.2 pF 0603	Murata	GRM39C0G1R2C50V
Capacitor	C7, C9, C10	1000pF 0603	Murata	GRM39C0G102J50V
Capacitor	C8, C11	0.1 uF 0603	Murata	GRM39Y5V104Z25V
Capacitor	C12	4.7uF Tantalum Cap.		
Resistor	R1	2R4 0603		

CONNECTION DIAGRAM AND PIN DESCRIPTIONS

Pin #	Name	Description
1, 5	GND	Ground
2	RF IN	RF input (internally DC blocked)
3	N/A	
4	Vg	FET gate bias
6, 7	RF OUT	RF output and V_{d2} external matching circuit required
8	Vd	Input stage drain bias

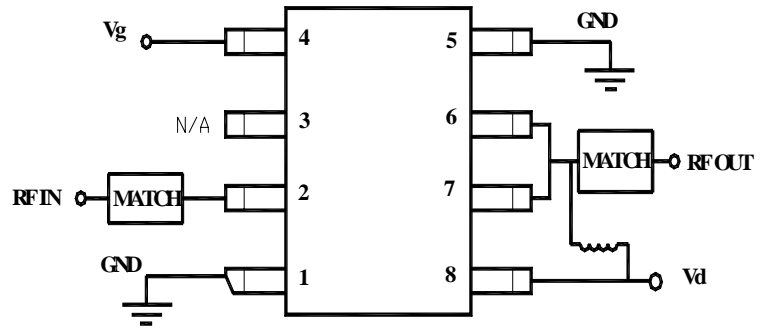
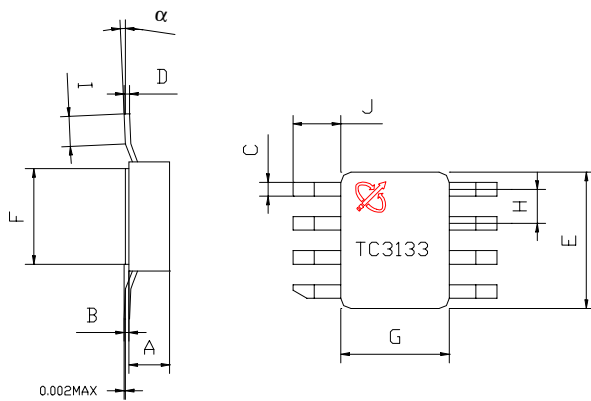
PHYSICAL DIMENSIONS (Unit: inch)

DIMENSION	MINIMUM	NOMINAL	MAXIMUM
A	0.083	0.086	0.089
B	0.007	0.008	0.009
C	0.017	0.020	0.023
D	0.007	0.008	0.009
E	0.195	0.200	0.205
F	0.135	0.140	0.145
G	0.155	0.160	0.165
H		0.050	
I	0.020		0.040
J	0.055	0.065	0.075
α	0°		7°