



QESM405

HC49 SMD 4 pins Crystal SERIES – Microprocessor Application
Specification (Rev-D)

▣ Electrical Characteristics	P01
▣ Mechanical Characteristics	P01
▣ Internal Connection	P02
▣ ESR vs Frequency range	P02
▣ Ordering Information	P02
▣ Tape Drawing.....	P03
▣ Reel Drawing	P03

QESM405

HC49 SMD 4 Pins Crystal SERIES – Microprocessor Application Specification (rev-D)

January 27th, 2006

Electrical Characteristics

Electrical Parameters	Unit	Minimum	Typical	Maximum	Test conditions
Frequency range	MHz	3.579		60	
Frequency tolerance at 25°C	±ppm	10	30	50	Refer to Ordering Information
Frequency stability	±ppm	10	30	50	Refer to Ordering Information
Operating temperature range (see table 1)	°C		-10 to +70	-40 to +85	Refer to Ordering Information
Storage temperature range	°C	-40		+85	
Shunt capacitance C0	pF			7.0	
Load capacitance	pF	10pF ~ 30pF or series			Refer to Ordering Information
Drive Level	µW		100	500	
Aging (First Year)	± ppm			5	Ref at 25°C
Insulation Resistance	MΩ	500			Ref at 100Vdc

Mechanical Characteristics

BOTTOM VIEW

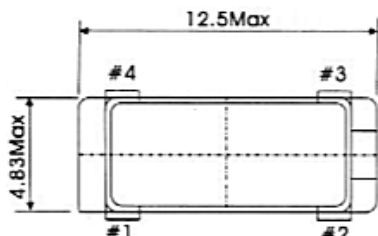

Hmax = 4.2 mm

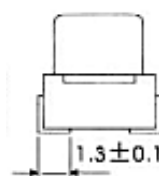
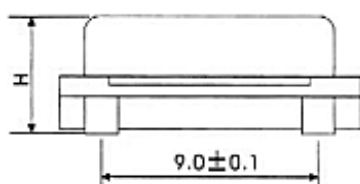

SUGGESTED PAD

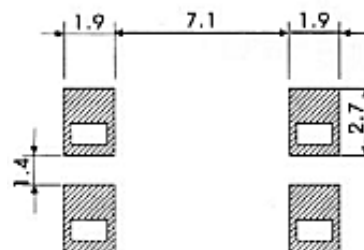

Marking

QESM405	A + Frequency in MHz (6 digits on the top)
QESM406	B + Frequency in MHz (6 digits on the top)
QESM407	C + Frequency in MHz (6 digits on the top)

QESM405

HC49 SMD 4 Pins Crystal SERIES – Microprocessor Application

Specification (rev-D)

January 27th, 2006

Internal Connection

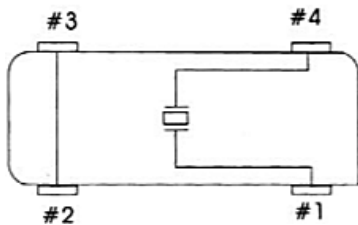

QESM405

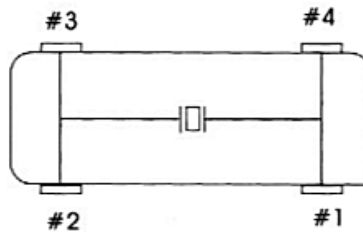

QESM406

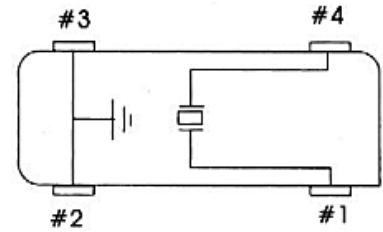

QESM407

ESR vs Frequency range

Table 1 : ESR vs frequency range

Frequency range (MHz)	Mode of vibration	Max. ESR (Ω)	Frequency range (MHz)	Mode of vibration	Max. ESR (Ω)
3.579 ~ 5.000	Fund. / AT	150	9.001 ~ 10.000	Fund. / AT	60
5.001 ~ 6.000	Fund. / AT	120	10.001 ~ 13.000	Fund. / AT	50
6.001 ~ 7.000	Fund. / AT	100	13.001 ~ 30.000	Fund. / AT	40
7.001 ~ 8.000	Fund. / AT	90	30.000 ~ 60.000	3 rd / AT	80
8.001 ~ 9.000	Fund. / AT	80			

Ordering Information

Part numbering system						
QESM405	1	30	HQ	50	30	3.57954MHZ
Package type	Vibration mode	Frequency tolerance	Operating temperature range	Frequency stability	Load capacitance	Nominal Frequency (MHz)
HC49 SMD 4 Pins Package QESM405 QESM406 QESM407	1 : Fundamental 3 : 3rd Overtone	10 : ± 10ppm 30 : ± 30ppm 50 : ± 50ppm	D : -40°C F : -30°C J : -10°C L : 0°C M : +50°C N : +55°C O : +60°C Q : +70°C T : +85°C	10 : ± 10ppm 30 : ± 30ppm 50 : ± 50ppm	00 : series 10 : 10pF 30 : 30pF Please, enter the value of load capacitance	Please enter the nominal frequency

QESM405

HC49 SMD 4 Pins Crystal SERIES – Microprocessor Application
 Specification (rev-D)

January 27th, 2006

▣ Tape Drawing

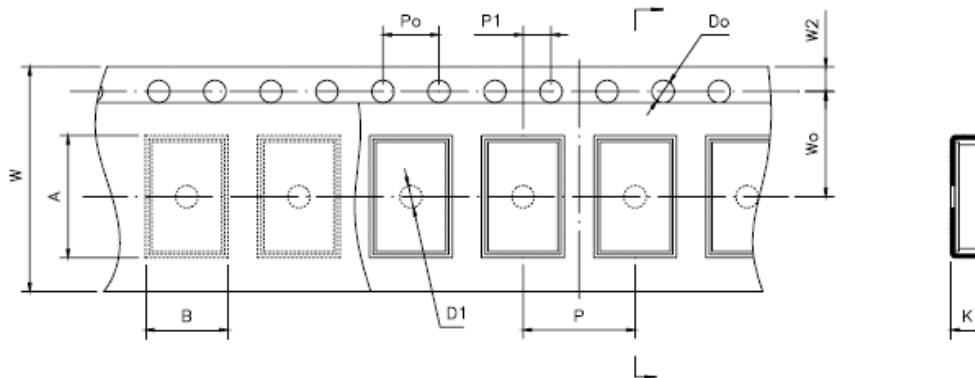

Item	Code	Dimension	Tolerance
Pitch of components	P	12.0	± 0.1
Pitch of sprocket hole	Po	4.0	± 0.1
Length from hole center to component center	P1	2.0	± 0.1
Width of carrier tape	W	24.0	± 0.3
Width of adhesive tape	W0	11.5	± 0.1
Height of component hole	A	13.4	± 0.1
Width of component hole	B	5.20	± 0.1
Gap of hold down tape and carrier tape	W2	1.75	± 0.1
Diameter of sprocket hole	Do	∅ 1.55	± 0.05
Diameter of feed hole	D1	∅ 2.0	± 0.2
Total of tape thickness	K	5.2 or 4.3	± 0.1

▣ Reel Drawing

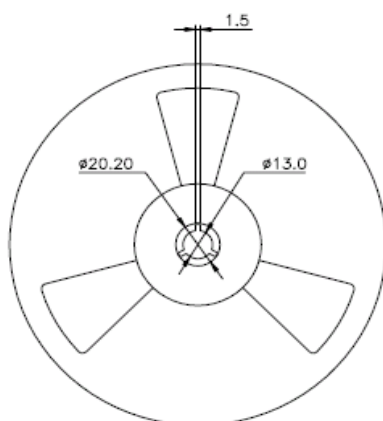

Multiple : 1Kpcs per Reel

Unit : mm

