

Quad Single Supply Comparator

IL2901

The IL2901 consists of four independent precision voltage comparators with an offset voltage specification as low as 2.0 mV max for four comparators which were designed specifically to operate from a single power supply over a wide range of voltages.

Application areas include limit comparators, simple analog to digital converters; pulse, square wave and time delay generators; wide range VCO; MOS clock timers; multivibrators and high voltage digital logic gates.

- Single or Split Supply Operation
- Low Input Bias Current
- Low Input Offset Current
- Input Common Mode Voltage Range to Gnd
- Low Output Saturation Voltage
- TTL and CMOS Compatible

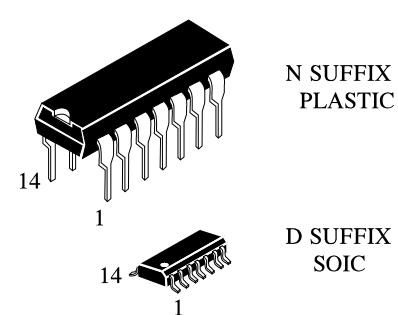

N SUFFIX
PLASTIC

D SUFFIX
SOIC

ORDERING INFORMATION
 IL2901N Plastic
 IL2901D SOIC
 $T_A = -40^\circ$ to 85° C for all packages.

LOGIC DIAGRAM

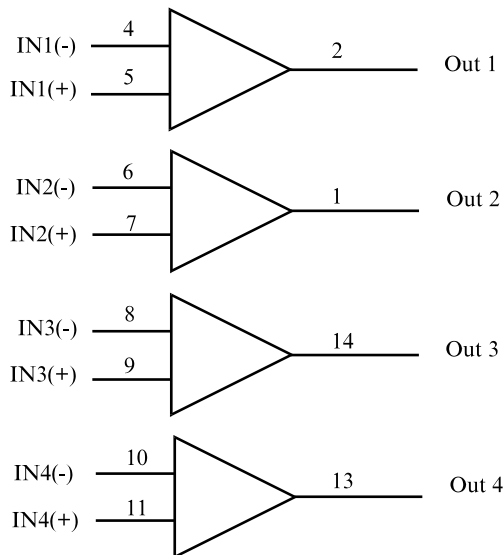

PIN 3 = V_{CC}
 PIN 12 = GND

PIN ASSIGNMENT

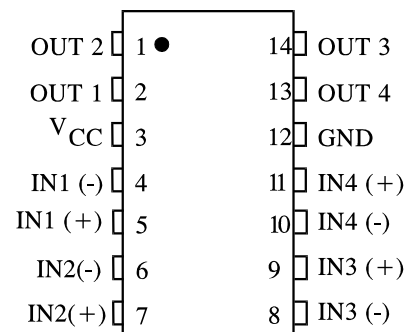

MAXIMUM RATINGS*

Symbol	Parameter	Value	Unit
V _{CC}	Power Supply Voltages		
	Single Supply Split Supplies	36 ±18	V
V _{IDR}	Input Differential Voltage Range	36	V
V _{ICR}	Input Common Mode Voltage Range (1)	-0.3 to V _{CC}	V
I _{SC}	Output Short Circuit to Ground	Continuous	
I _{IN}	Input Current, per pin (2)	50	mA
T _J	Junction Temperature		
	Plastic Packages	150	°C
T _{stg}	Storage Temperature	-65 to +150	°C
T _L	Lead Temperature, 1mm from Case for 10 Seconds	260	°C
P _D	Power Dissipation @T _A =25°C		
	Plastic Package	1.0	W
	Derate above 25°C	8.0	mW/°C

* Stresses beyond those listed under “absolute maximum ratings” may cause permanent damage to the device. These are stress ratings only and functional operation of the device at these or any other conditions beyond those indicated under “recommended operating conditions” is not implied.

Exposure to absolute-maximum-rated conditions for extended periods may affect device reliability.

Functional operation should be restricted to the Recommended Operating Conditions.

Notes:

1. Split Power Supplies.
2. V_{IN}<-0.3V. This input current will only exist when voltage at any of the input leads is driven negative.

RECOMMENDED OPERATING CONDITIONS

Symbol	Parameter	Min	Max	Unit
V _{CC}	DC Supply Voltage	±2.5 or 5.0	±15 or 30	V
T _A	Operating Temperature, All Package Types	-40	+85	°C

This device contains protection circuitry to guard against damage due to high static voltages or electric fields. However, precautions must be taken to avoid applications of any voltage higher than maximum rated voltages to this high-impedance circuit. For proper operation, V_{IN} and V_{OUT} should be constrained to the range GND ≤ (V_{IN} or V_{OUT}) ≤ V_{CC}.

Unused inputs must always be tied to an appropriate logic voltage level (e.g., either GND or V_{CC}). Unused outputs must be left open.

DC ELECTRICAL CHARACTERISTICS ($T_A=-40$ to $+85^\circ\text{C}$)

Symbol	Parameter	Test Conditions	Guaranteed Limit			Unit
			Min	Typ	Max	
V_{IO}	Input Offset Voltage	$V_0=1.4\text{V}$ $V_{CC}=5.0\text{-}30\text{V}; R_S \leq 100\Omega$ $V_{ICR}=0\text{V} - (V_{CC}-1.5)\text{V}$	-		9.0 5.0*	mV
I_{IB}	Input Bias Current	$V_0=1.4\text{V}$ $V_{CC}=5.0\text{-}30\text{V}$ $V_{ICR}=0\text{V} - (V_{CC}-1.5)\text{V}$	-		400	nA
I_{IO}	Input Offset Current	$V_0=1.4\text{V}$ $V_{CC}=5.0\text{-}30\text{V}$ $V_{ICR}=0\text{V} - (V_{CC}-1.5)\text{V}$	-		± 150	nA
V_{ICR}	Input Common Mode Voltage Range	$V_{CC}=5.0\text{-}30\text{V}$	0		$V_{CC}-2.0\text{V}$	V
I_{CC}	Supply Current	$R_L=\infty, V_{CC}=5.0$ $R_L=\infty, V_{CC}=30\text{V}$	- -		2.0* 2.5*	mA
A_{VOL}	Voltage Gain	$V_{CC}=15\text{V}, R_L=15\text{K}\Omega$	-	200*	-	V/mV
t_1	Large Signal Response Time	$V_{IN}=\text{TTL Logic Swing}$, $V_{ref}=1.4\text{V}, V_{CC}=5.0\text{V}$, $R_L=5.1\text{K}\Omega, V_{RL}=5.0\text{V}$	-	300*	-	ns
t_2	Response Time	$V_{CC}=5.0\text{V}, R_L=5.1\text{K}\Omega$, $V_{RL}=5.0\text{V}$	-	1.3*	-	μs
I_{sink}	Output Sink Current	$V_{I(-)}=1.0\text{V}, V_{I(+)}=0\text{V}$, $V_0 \leq 1.5\text{V}, V_{CC}=5.0\text{V}$	6.0*	-	-	mA
V_{sat}	Saturation Voltage	$V_{I(-)}=1.0\text{V}, V_{I(+)}=0\text{V}$, $I_{sink} \leq 4.0\text{mA}, V_{CC}=5.0\text{V}$	-	-	700	mV
I_{OL}	Output Leakage Current	$V_{I(+)}=1.0\text{V}, V_{I(-)}=0\text{V}$, $V_0=5.0\text{V}$ $V_0=30\text{V}$		0.1*	1000	nA
V_{IDR}	Differential Input Voltage Range	All $V_{IN} \geq \text{GND}$ or $V\text{-Supply}$ (if used)			V_{CC}^*	V

*=@25°C

TYPICAL PERFORMANCE CHARACTERISTICS

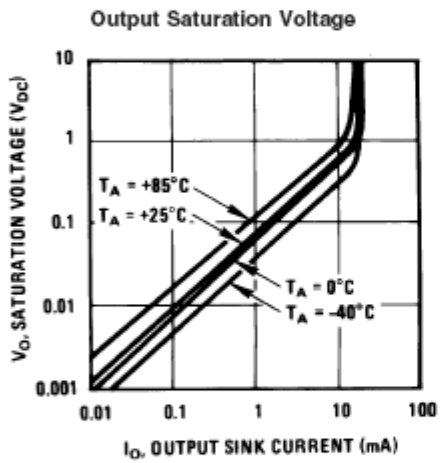
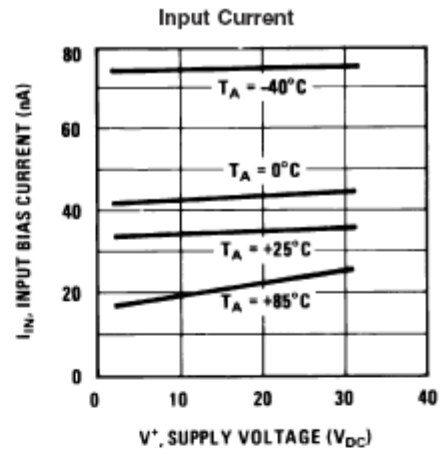
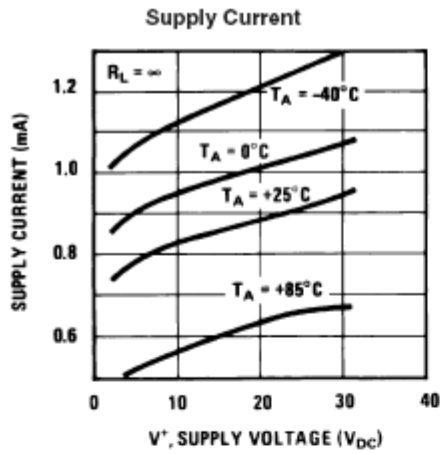

Response Time for Various Input Overdrives — Negative Transition

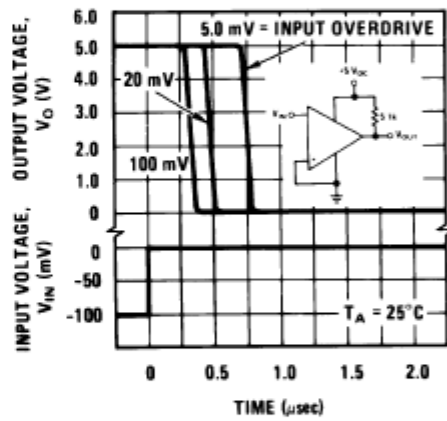

Response Time for Various Input Overdrives — Positive Transition

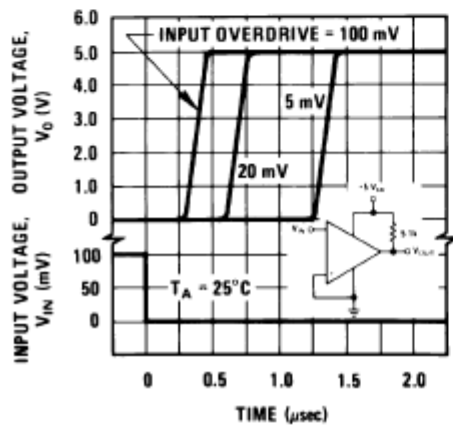

APPLICATION NOTE

The IL2901 is high gain, wide bandwidth devices which, like most comparators, can easily oscillate if the output lead is inadvertently allowed to capacitively couple to the inputs via stray capacitance. This shows up only during the output voltage transition intervals as the comparator changes states. Power supply bypassing is not required to solve this problem. Standard PC board layout is helpful as it reduces stray input-output coupling. Reducing these input resistors to < 10 kΩ reduces the feedback signal levels and finally, adding even a small amount (1 to 10 mV) of positive feedback (hysteresis) causes such a rapid transition that oscillations due to stray feedback are not possible. Simply socketing the IC and attaching resistors to the pins will cause input-output oscillations during the small transition intervals unless hysteresis is used. If the input signal is a pulse waveform, with relatively fast rise and fall times, hysteresis is not required.

All pins of any unused comparators should be tied to the negative supply.

The bias network of the IL2901 establishes a drain current which is independent of the magnitude of the power supply voltage over the range of from 2 VDC to 30 VDC.

It is usually unnecessary to use a bypass capacitor across the power supply line.

The differential input voltage may be larger than V+ without damaging the device.

Protection should be provided to prevent the input voltages from going negative more than -0.3 VDC (at 25°C). An input clamp diode can be used as shown in the applications section.

TYPICAL APPLICATIONS (V+ = 5.0V_{DC})

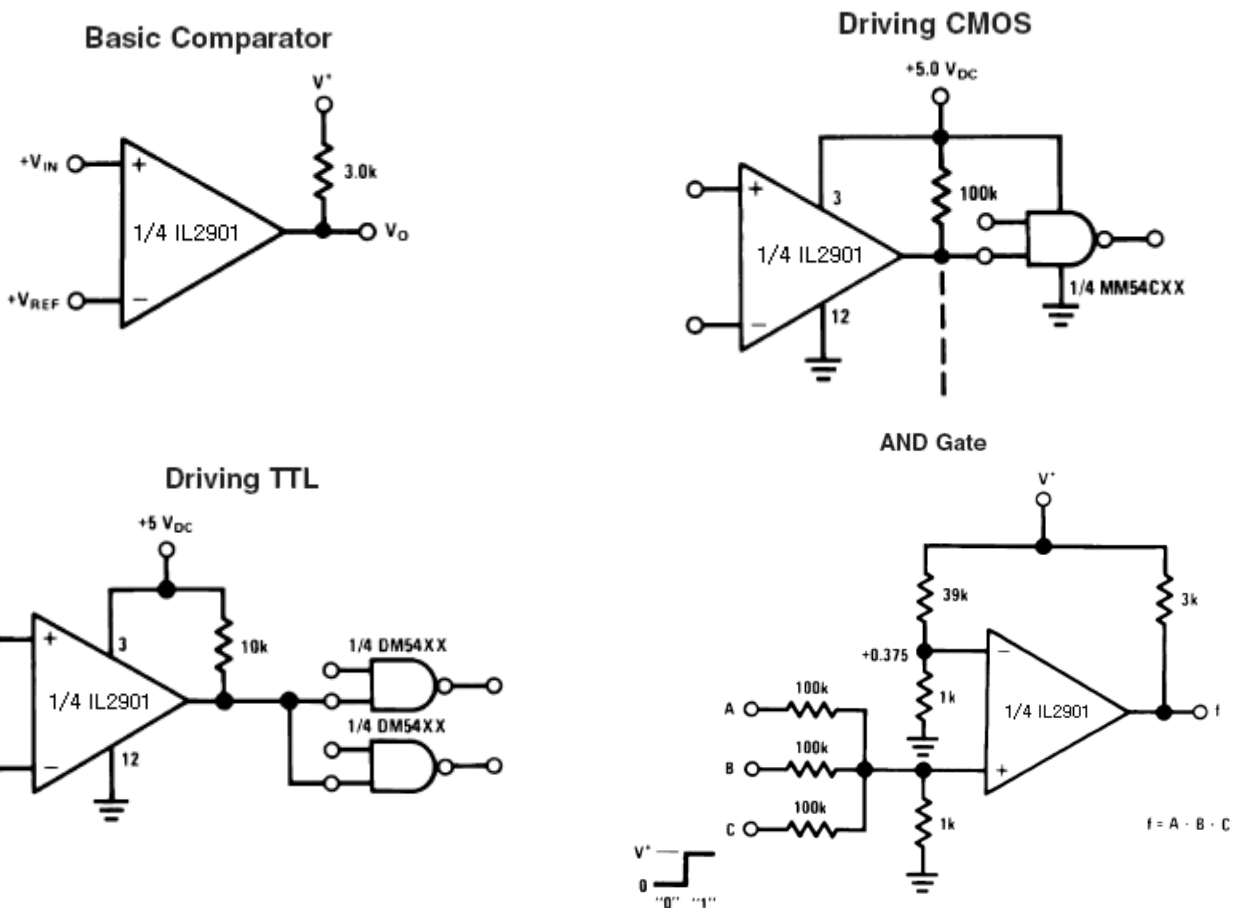

TYPICAL APPLICATIONS ($V^+ = 5.0V_{DC}$)

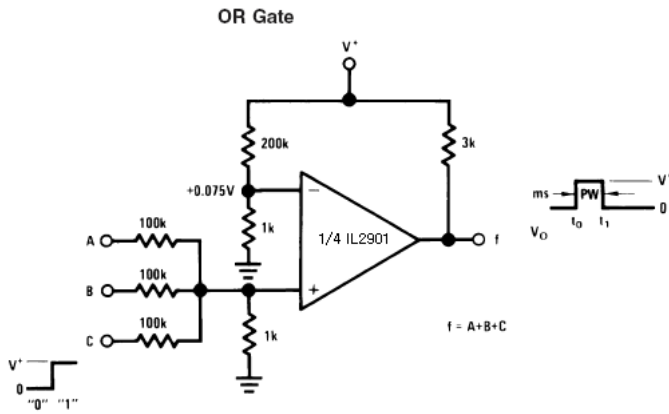

TYPICAL APPLICATIONS ($V^+ = 15.0V_{DC}$)

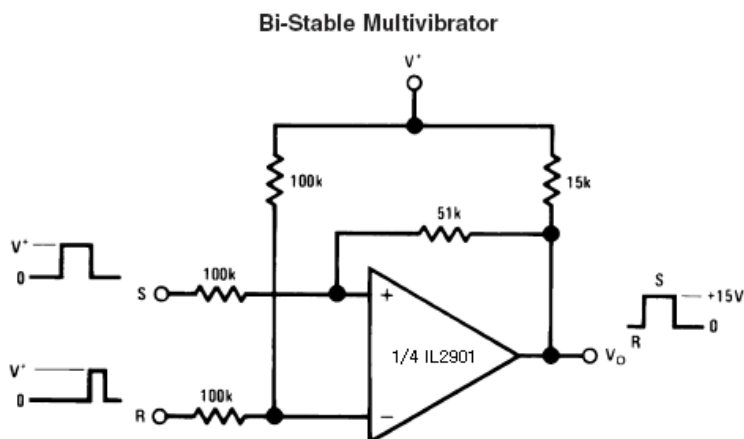
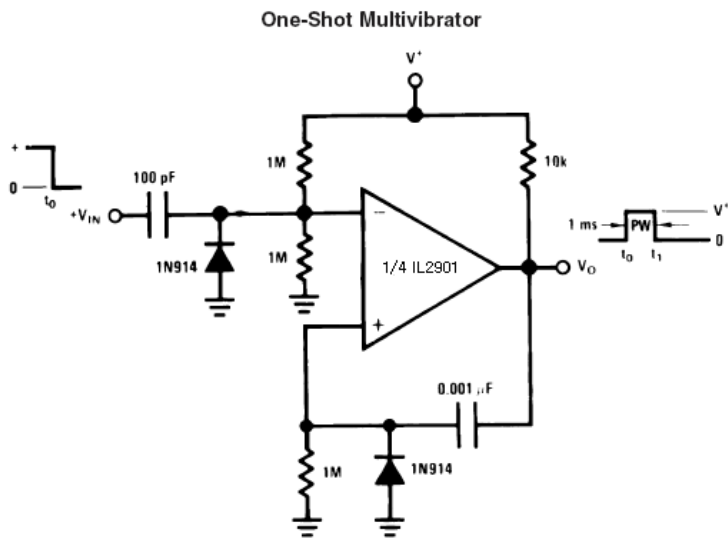

TYPICAL APPLICATIONS ($V^+ = 15.0V_{DC}$)

One-Shot Multivibrator with Input Lock Out

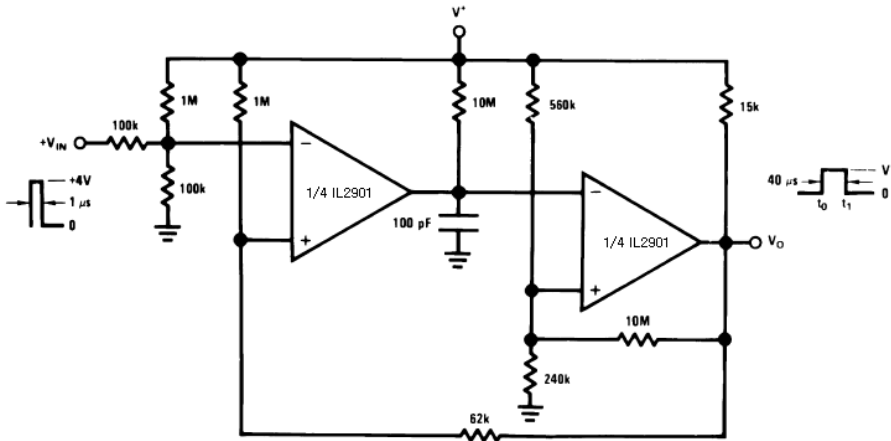

Large Fan-In AND Gate

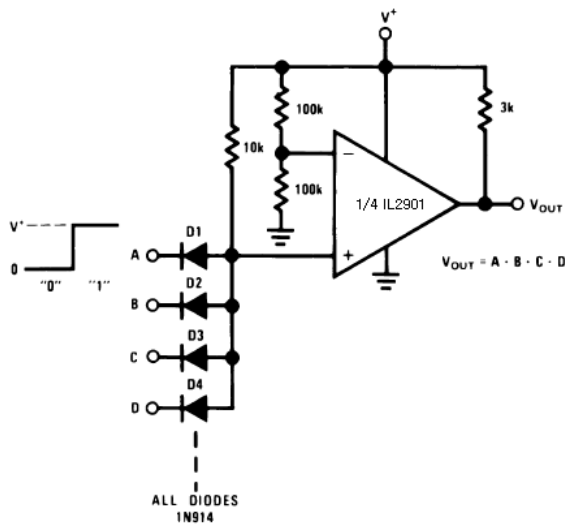

Pulse Generator

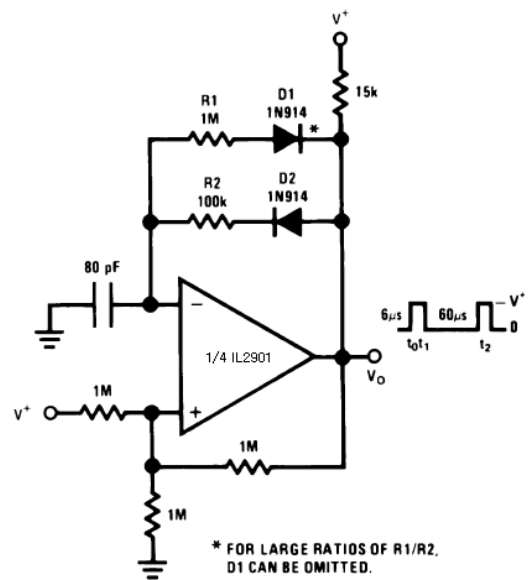

Two-Decade High-Frequency VCO

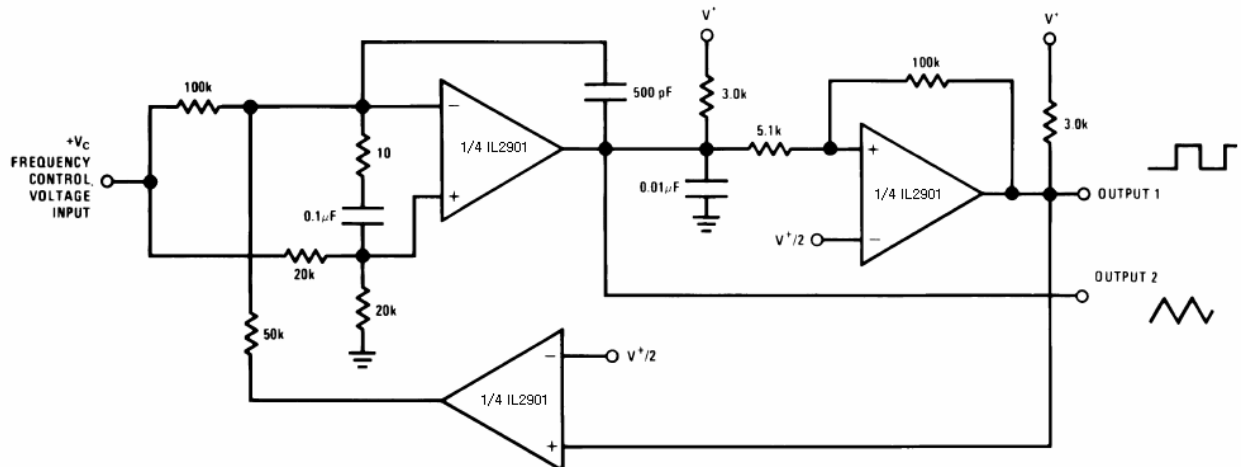

$V^+ = +30 V_{DC}$
 $250 mV_{DC} \leq V_C \leq +50 V_{DC}$
 $700 Hz \leq f_0 \leq 100 kHz$

TYPICAL APPLICATIONS ($V^+ = 15.0V_{DC}$)

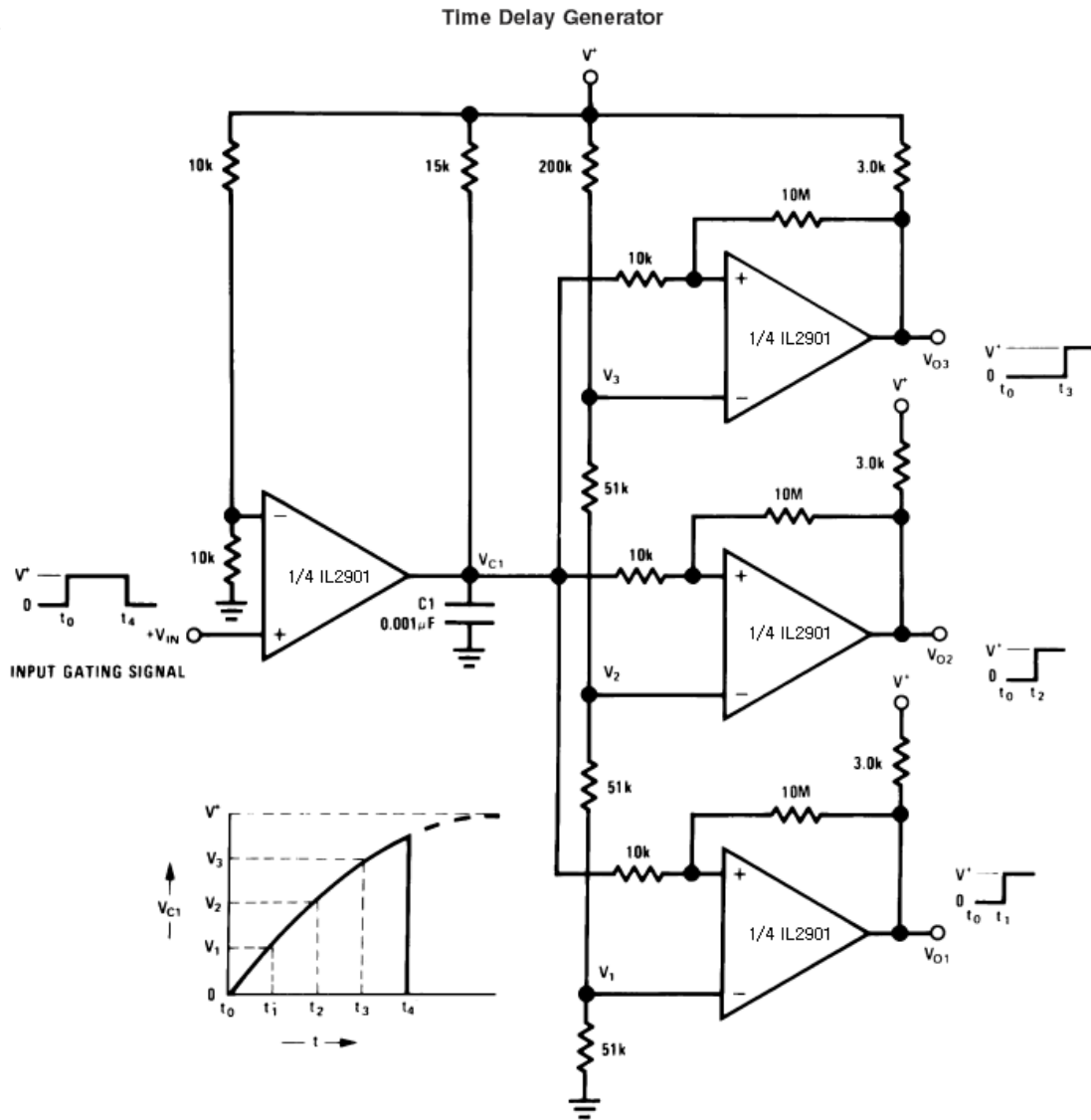

Non-Inverting Comparator with Hysteresis

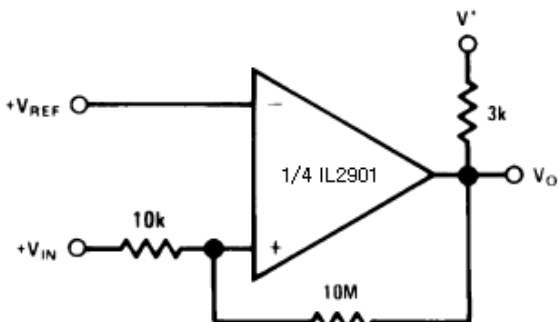

Inverting Comparator with Hysteresis

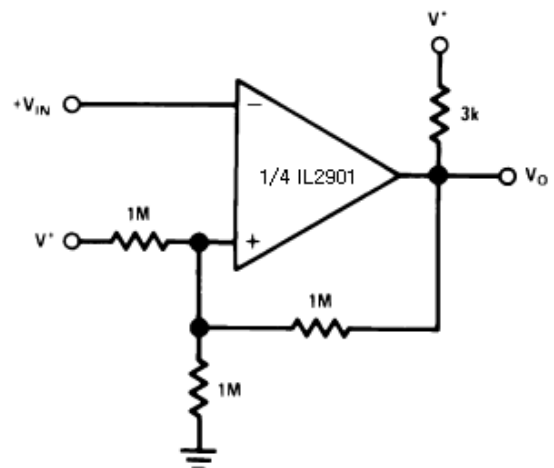

TYPICAL APPLICATIONS ($V^+ = 15.0V_{DC}$)

Squarewave Oscillator

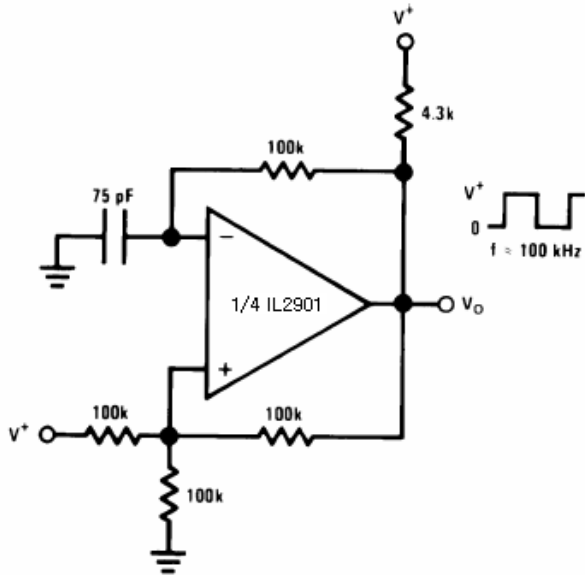

Comparing Input Voltages of Opposite Polarity

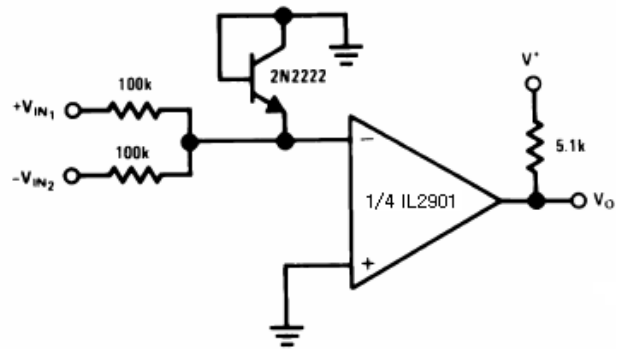

Output Strobing

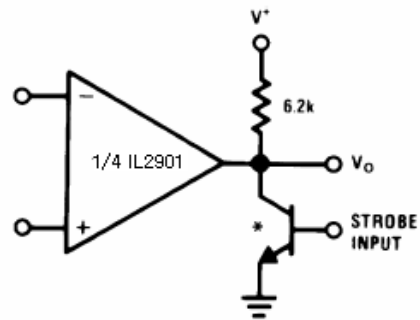

* Or open-collector logic gate without pull-up resistor

Basic Comparator

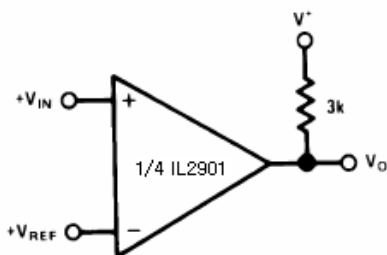

Crystal Controlled Oscillator

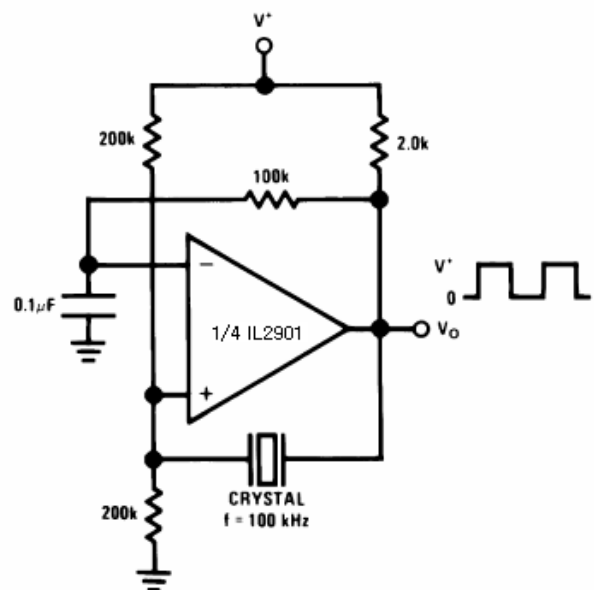

Limit Comparator

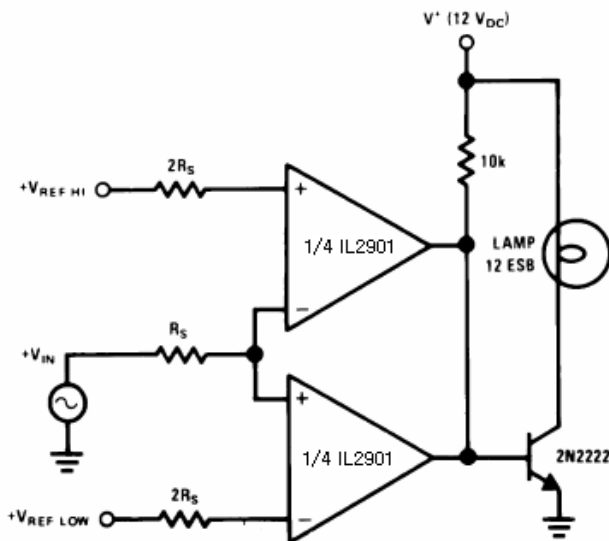

TYPICAL APPLICATIONS ($V^+ = 15.0V_{DC}$)

Transducer Amplifier

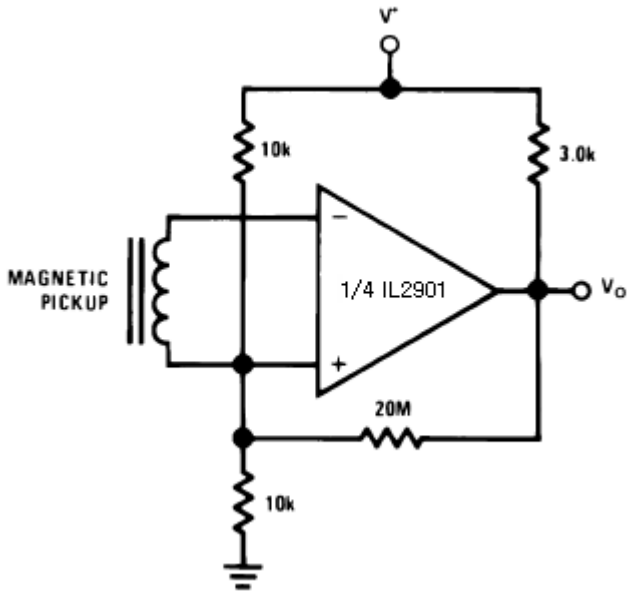

ORing the Outputs

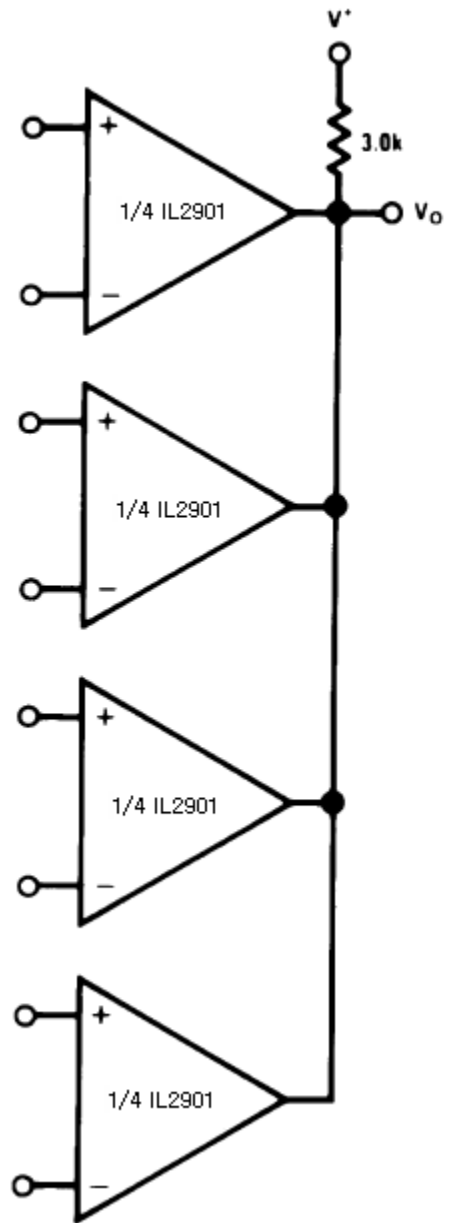

Zero Crossing Detector (Single Power Supply)

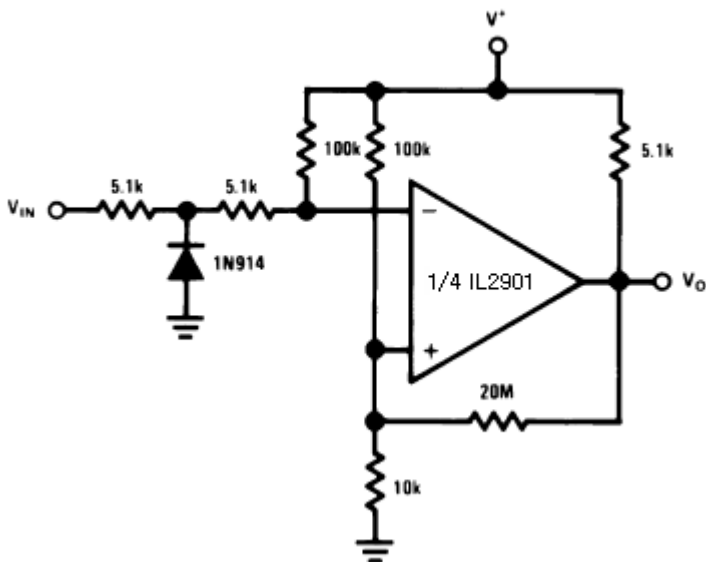

SPLIT SUPPLY APPLICATIONS ($V^+ = 15.0V_{DC}$ and $V^- = -15.0V_{DC}$)

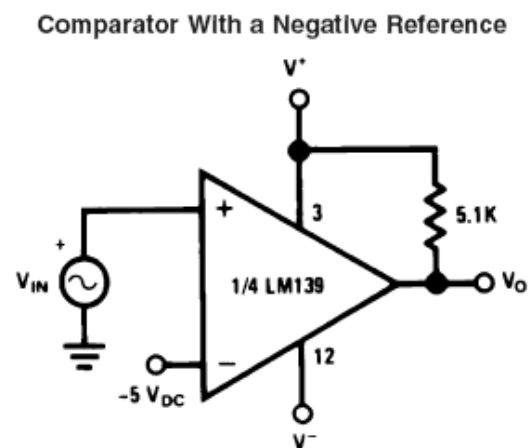
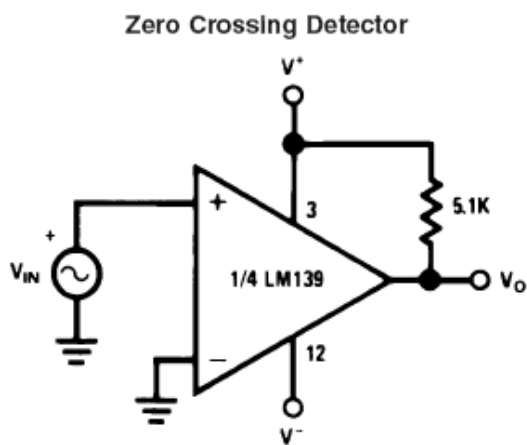
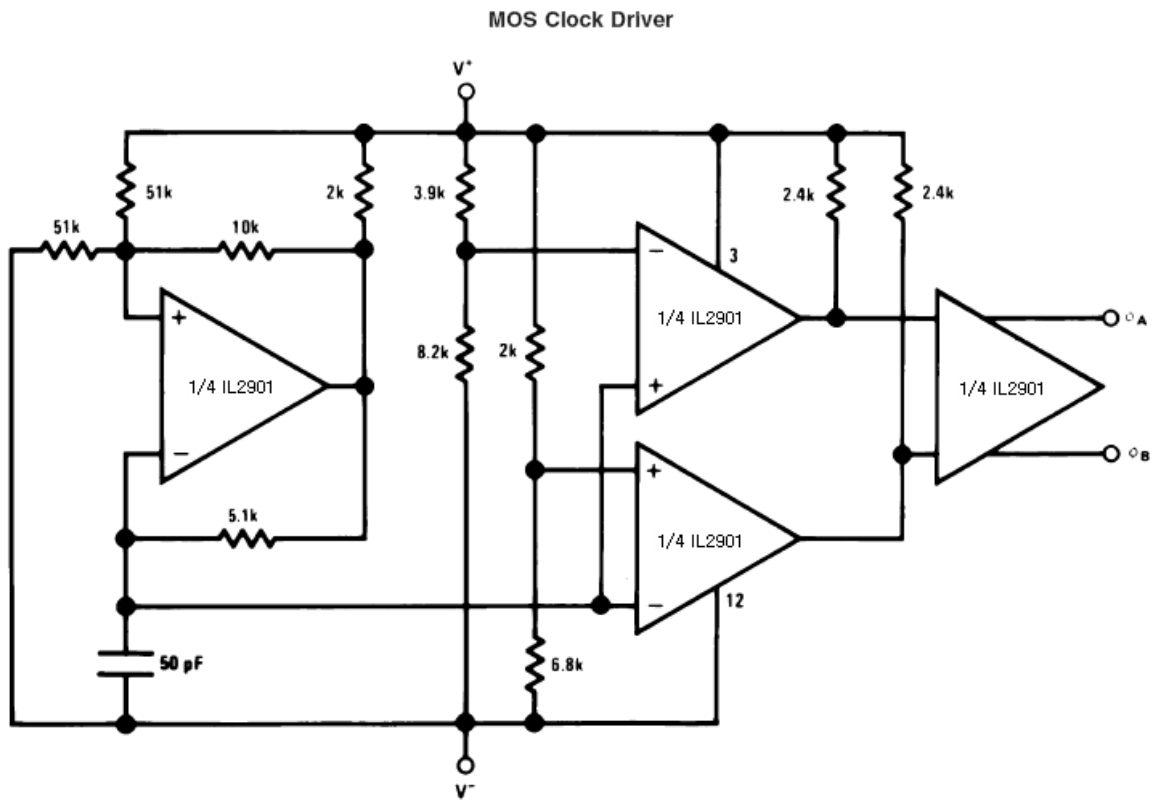

**N SUFFIX PLASTIC DIP
(MS - 001AA)**

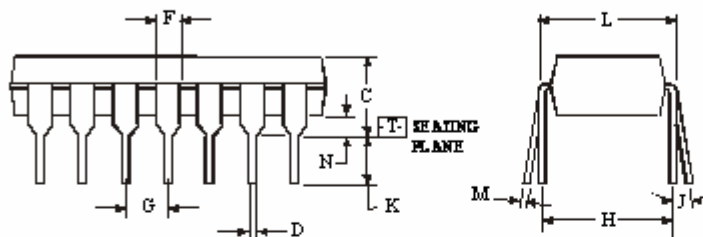
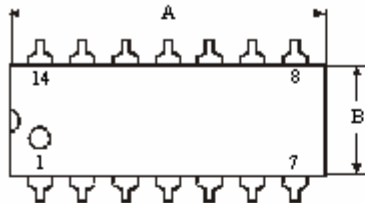
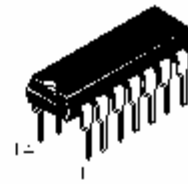

$\oplus 0.25 (0.010) \text{ T}$

NOTES:

- Dimensions "A", "B" do not include mold flash or protrusions.
Maximum mold flash or protrusions 0.25 mm (0.010) per side.

Symbol	Dimension, mm	
	MIN	MAX
A	18.67	19.69
B	6.1	7.11
C		5.33
D	0.36	0.56
F	1.14	1.78
G	2.54	
H	7.62	
J	0°	10°
K	2.92	3.81
L	7.62	8.26
M	0.2	0.36
N	0.38	

**D SUFFIX SOIC
(MS - 012AB)**

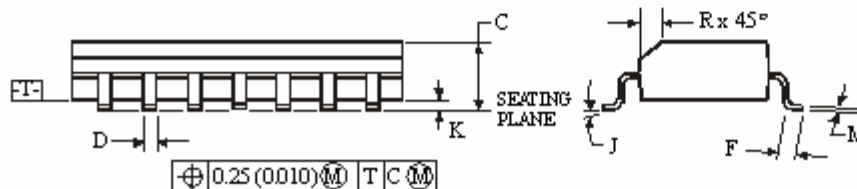
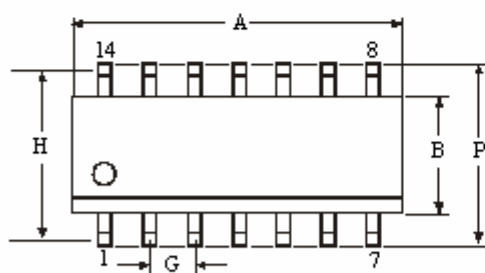

$\oplus 0.25 (0.010) \text{ T C}$

NOTES:

- Dimensions A and B do not include mold flash or protrusion.
- Maximum mold flash or protrusion 0.15 mm (0.006) per side
for A; for B - 0.25 mm (0.010) per side.

Symbol	Dimension, mm	
	MIN	MAX
A	8.55	8.75
B	3.8	4
C	1.35	1.75
D	0.33	0.51
F	0.4	1.27
G	1.27	
H	5.27	
J	0°	8°
K	0.1	0.25
M	0.19	0.25
P	5.8	6.2
R	0.25	0.5