

# FAN2110 — TinyBuck™, 3-24 V Input, 10 A, High-Efficiency, Integrated Synchronous Buck Regulator

## Features

- Wide Input Voltage Range: 3 V-24 V
- Wide Output Voltage Range: 0.8 V to 80%  $V_{IN}$
- 10 A Output Current
- 1% Reference Accuracy Over Temperature
- Over 93% Peak Efficiency
- Programmable Frequency Operation: 200 KHz to 600 KHz
- Fully Synchronous Operation with Integrated Schottky Diode on Low-Side MOSFET Boosts Efficiency
- Internal Bootstrap Diode
- Power-Good Signal
- Starts up on Pre-Bias Outputs
- Accepts Ceramic Capacitors on Output
- External Compensation for Flexible Design
- Programmable Current Limit
- Under-Voltage, Over-Voltage, and Thermal Shutdown Protections
- Internal Soft-Start
- 5x6 mm, 25-Pin, 3-Pad MLP Package

## Applications

- Servers & Telecom
- Graphics Cards & Displays
- Computing Systems
- Point-of-Load Regulation
- Set-Top Boxes & Game Consoles

## Description

The FAN2110 TinyBuck™ is a highly efficient, small footprint, constant frequency, 10 A integrated synchronous Buck regulator.

The FAN2110 contains both synchronous MOSFETs and a controller/driver with optimized interconnects in one package, which enables designers to solve high-current requirements in a small area with minimal external components. Integration helps to minimize critical inductances making component layout simpler and more efficient compared to discrete solutions.

The FAN2110 provides for external loop compensation, programmable switching frequency, and current limit. These features allow design flexibility and optimization. High frequency operation allows for all ceramic solutions.

The summing current mode modulator uses lossless current sensing for current feedback and over-current protection. Voltage feedforward helps operation over a wide input voltage range.

Fairchild's advanced BiCMOS power process, combined with low- $R_{DS(ON)}$  internal MOSFETs and a thermally efficient MLP package, provide the ability to dissipate high power in a small package.

Output over-voltage, under-voltage, and thermal shutdown protections help protect the device from damage during fault conditions. FAN2110 also prevents pre-biased output discharge during startup in point-of-load applications.

## Related Application Notes

[TinyCalc™ Calculator Design Tool](#)

[AN-8022 — TinyCalc™ Calculator User Guide](#)

## Ordering Information

Part Number	Operating Temperature Range	Package	Packing Method
FAN2110MPX	-10°C to 85°C	Molded Leadless Package (MLP) 5x6 mm	Tape and Reel
FAN2110EMPX	-40°C to 85°C	Molded Leadless Package (MLP) 5x6 mm	Tape and Reel

### Typical Application

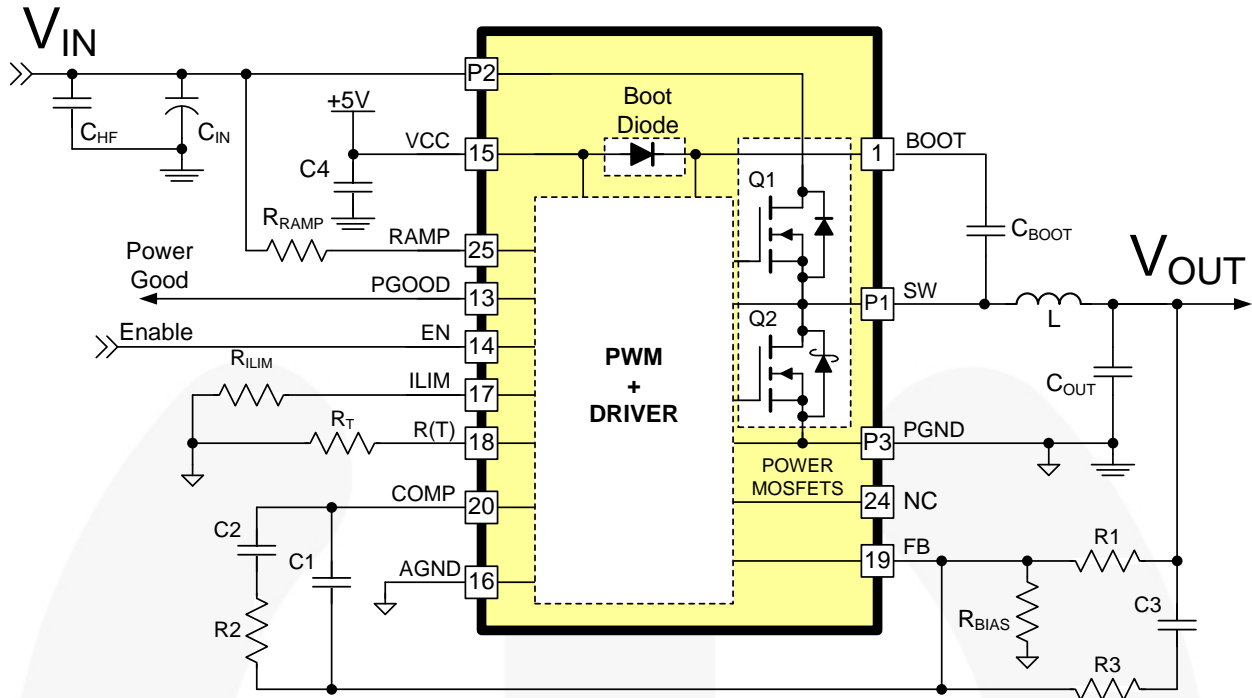

Figure 1. Typical Application Diagram

### Block Diagram

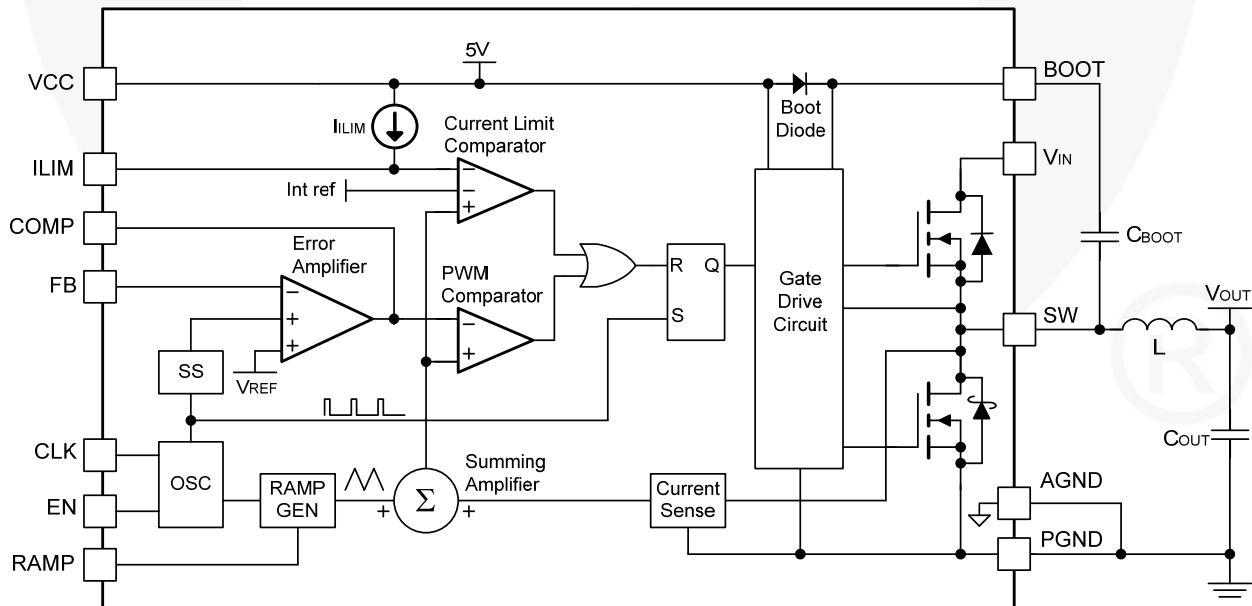

Figure 2. Block Diagram

## Pin Configuration

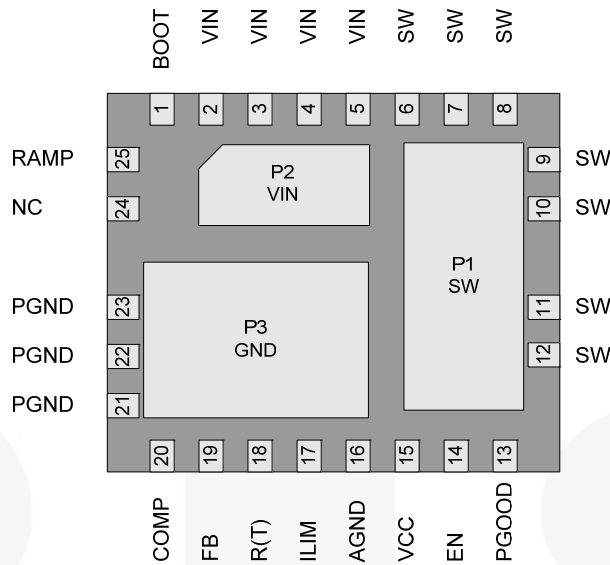

Figure 3. MLP 5x6 mm Pin Configuration (Bottom View)

## Pin Definitions

Pin #	Name	Description
P1, 6-12	SW	<b>Switching Node.</b> Junction of high-side and low-side MOSFETs.
P2, 2-5	VIN	<b>Power Conversion Input Voltage.</b> Connect to the main input power source.
P3, 21-23	PGND	<b>Power Ground.</b> Power return and Q2 source.
1	BOOT	<b>High-Side Drive BOOT Voltage.</b> Connect through capacitor ( $C_{BOOT}$ ) to SW. The IC includes an internal synchronous bootstrap diode to recharge the capacitor on this pin to $V_{CC}$ when SW is LOW.
13	PGOOD	<b>Power-Good Flag.</b> An open-drain output that pulls LOW when FB is outside the limits specified in electrical specs. PGOOD does not assert HIGH until the fault latch is enabled.
14	EN	<b>ENABLE.</b> Enables operation when pulled to logic HIGH or left open. Toggling EN resets the regulator after a latched fault condition. This input has an internal pull-up when the IC is functioning normally. When a latched fault occurs, EN is discharged by a current sink.
15	VCC	<b>Input Bias Supply for IC.</b> The IC's logic and analog circuitry are powered from this pin. This pin should be decoupled to AGND through a $> 2.2 \mu\text{F}$ X5R / X7R capacitor.
16	AGND	<b>Analog Ground.</b> The signal ground for the IC. All internal control voltages are referred to this pin. Tie this pin to the ground island/plane through the lowest impedance connection.
17	ILIM	<b>Current Limit.</b> A resistor ( $R_{ILIM}$ ) from this pin to AGND can be used to program the current-limit trip threshold lower than the internal default setting.
18	R(T)	<b>Oscillator Frequency.</b> A resistor ( $R_T$ ) from this pin to AGND sets the PWM switching frequency.
19	FB	<b>Output Voltage Feedback.</b> Connect through a resistor divider to the output voltage.
20	COMP	<b>Compensation.</b> Error amplifier output. Connect the external compensation network between this pin and FB.
24	NC	<b>No Connect.</b> This pin is not used.
25	RAMP	<b>Ramp Amplitude.</b> A resistor ( $R_{RAMP}$ ) connected from this pin to $V_{IN}$ sets the ramp amplitude and provides voltage feedforward functionality.

## Absolute Maximum Ratings

Stresses exceeding the absolute maximum ratings may damage the device. The device may not function or be operable above the recommended operating conditions and stressing the parts to these levels is not recommended. In addition, extended exposure to stresses above the recommended operating conditions may affect device reliability. The absolute maximum ratings are stress ratings only.

Parameter	Conditions	Min.	Max.	Unit
V <sub>IN</sub> to PGND			28	V
V <sub>CC</sub> to AGND	AGND=PGND		6	V
BOOT to PGND			35	V
BOOT to SW		-0.5	6.0	V
SW to PGND	Continuous	-0.5	24.0	V
	Transient (t < 20 ns, f ≤ 600 KHz)	-5	30	V
All other pins		-0.3	V <sub>CC</sub> +0.3	V
ESD	Human Body Model, JEDEC JESD22-A114	2.0		KV
	Charged Device Model, JEDEC JESD22-C101	2.5		

## Recommended Operating Conditions

The Recommended Operating Conditions table defines the conditions for actual device operation. Recommended operating conditions are specified to ensure optimal performance to the datasheet specifications. Fairchild does not recommend exceeding them or designing to absolute maximum ratings.

Symbol	Parameter	Conditions	Min.	Typ.	Max.	Unit
V <sub>CC</sub>	Bias Voltage	V <sub>CC</sub> to AGND	4.5	5.0	5.5	V
V <sub>IN</sub>	Supply Voltage	V <sub>IN</sub> to PGND	3		24	V
T <sub>A</sub>	Ambient Temperature	FAN2110MPX	-10		+85	°C
		FAN2110EMPX	-40		+85	°C
T <sub>J</sub>	Junction Temperature				+125	°C
f <sub>SW</sub>	Switching Frequency		200		600	kHz

## Thermal Information

Symbol	Parameter	Min.	Typ.	Max.	Unit
T <sub>STG</sub>	Storage Temperature	-65		+150	°C
T <sub>L</sub>	Lead Soldering Temperature, 10 Seconds			+300	°C
θ <sub>JC</sub>	Thermal Resistance: Junction-to-Case	P1 (Q2)		4	°C/W
		P2 (Q1)		7	°C/W
		P3		4	°C/W
θ <sub>J-PCB</sub>	Thermal Resistance: Junction-to-Mounting Surface <sup>(1)</sup>		35		°C/W
P <sub>D</sub>	Power Dissipation, T <sub>A</sub> =25°C <sup>(1)</sup>			2.8	W

### Note:

1. Typical thermal resistance when mounted on a four-layer, two-ounce PCB, as shown in Figure 35. Actual results are dependent on mounting method and surface related to the design.

## Electrical Specifications

Electrical specifications are the result of using the circuit shown in Figure 1 with  $V_{IN}=12$  V, unless otherwise noted.

Symbol	Parameter	Conditions	Min.	Typ.	Max.	Unit
<b>Power Supplies</b>						
$I_{CC}$	$V_{CC}$ Current	SW=Open, $V_{FB}=0.7$ V, $V_{CC}=5$ V, $f_{SW}=600$ KHz		8	12	mA
		Shutdown: EN=0, $V_{CC}=5$ V		7	10	$\mu$ A
$V_{UVLO}$	$V_{CC}$ UVLO Threshold	Rising $V_{CC}$	4.1	4.3	4.5	V
		Hysteresis		300		mV
<b>Oscillator</b>						
$f_{SW}$	Frequency	$R_T=50$ K $\Omega$ to GND	255	300	345	KHz
		$R_T=24$ K $\Omega$ to GND	540	600	660	KHz
$t_{ONmin}$	Minimum On-Time <sup>(2)</sup>			50	65	ns
$V_{RAMP}$	Ramp Amplitude, Peak-to-Peak	$16 V_{IN}$ , $1.8 V_{OUT}$ , $R_T=30$ K $\Omega$ , $R_{RAMP}=200$ K $\Omega$		0.53		V
$t_{OFFmin}$	Minimum Off-Time <sup>(2)</sup>			100	150	ns
<b>Reference</b>						
$V_{FB}$	Reference Voltage (see Figure 4 for Temperature Coefficient)	FAN2110MPX, 25°C	794	800	806	mV
		FAN2110EMPX, 25°C	795	800	805	mV
<b>Error Amplifier</b>						
G	DC Gain <sup>(2)</sup>	$V_{CC}=5$ V	80	85		dB
GBW	Gain Bandwidth Product <sup>(2)</sup>		12	15		MHz
$V_{COMP}$	Output Voltage <sup>(2)</sup>		0.4		3.2	V
$I_{SINK}$	Output Current, Sourcing	$V_{CC}=5$ V, $V_{COMP}=2.2$ V	1.5	2.2		mA
$I_{SOURCE}$	Output Current, Sinking	$V_{CC}=5$ V, $V_{COMP}=1.2$ V	0.8	1.2		mA
$I_{BIAS}$	FB Bias Current	$V_{FB}=0.8$ V, 25°C	-850	-650	-450	nA
<b>Protection and Shutdown</b>						
$I_{LIM}$	Current Limit (see Circuit Description) <sup>(2)</sup>	$R_{LIM}=182$ K $\Omega$ , 25°C, $f_{SW}=500$ KHz, $V_{OUT}=1.5$ V, $R_{RAMP}=243$ K $\Omega$ , 16 Consecutive Clock Cycles <sup>(3)</sup>	12	14	16	A
$I_{LIM}$	$I_{LIM}$ Current	$V_{CC}=5$ V, 25°C	-11	-10	-9	$\mu$ A
$T_{TSD}$	Over-Temperature Shutdown <sup>(2)</sup>	Internal IC Temperature		+155		°C
$T_{HYS}$	Over-Temperature Hysteresis <sup>(2)</sup>			+30		°C
$V_{OVP}$	Over-Voltage Threshold	2 Consecutive Clock Cycles <sup>(3)</sup>	110	115	121	% $V_{OUT}$
$V_{UVSD}$	Under-Voltage Shutdown	16 Consecutive Clock Cycles <sup>(3)</sup>	68	73	78	% $V_{OUT}$
$V_{FLT}$	Fault Discharge Threshold	Measured at FB Pin		250		mV
$V_{FLT\_HYS}$	Fault Discharge Hysteresis	Measured at FB Pin ( $V_{FB} \sim 500$ mV)		250		mV
<b>Soft-Start</b>						
$t_{SS}$	$V_{OUT}$ to Regulation (T0.8)	$f_{SW}=500$ KHz		5.3		ms
$t_{EN}$	Fault Enable/SSOK (T1.0) <sup>(2)</sup>			6.7		ms

Continued on the following page...

**Electrical Specifications** (Continued)

Electrical specifications are the result of using the circuit shown in Figure 1 with  $V_{IN}=12$  V, unless otherwise noted.

Symbol	Parameter	Conditions	Min.	Typ.	Max.	Unit
<b>Control Functions</b>						
$V_{EN}$	EN Threshold, Rising	$V_{CC}=5$ V		1.35	2.00	V
$V_{EN\_HYS}$	EN Hysteresis	$V_{CC}=5$ V		250		mV
$R_{EN}$	EN Pull-Up Resistance	$V_{CC}=5$ V		800		K $\Omega$
$I_{EN\_DISC}$	EN Discharge Current	Auto-Restart Mode, $V_{CC}=5$ V		1		$\mu$ A
$R_{FBok}$	FB OK Drive Resistance				800	$\Omega$
$V_{PGTH\_LO}$	PGOOD LOW Threshold	$FB < V_{REF}$ , 2 Consecutive Clock Cycles <sup>(3)</sup>	-14	-11	-8	% $V_{REF}$
$V_{PGTH\_UP}$		$FB > V_{REF}$ , 2 Consecutive Clock Cycles <sup>(3)</sup>	+7	+10	+13.5	
$V_{PG\_LO}$	PGOOD Output Low	$I_{OUT} \leq 2$ mA			0.4	V
$I_{PG\_LK}$	PGOOD Leakage Current	$V_{PGOOD}=5$ V		0.2	1.0	$\mu$ A

**Notes:**

- Specifications guaranteed by design and characterization; not production tested.
- Delay times are not tested in production. Guaranteed by design.

## Typical Characteristics

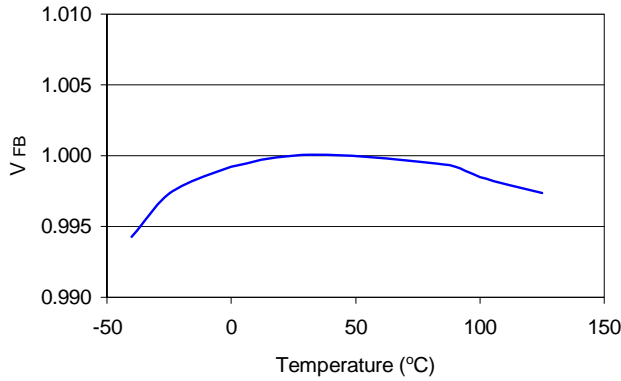

**Figure 4. Reference Voltage ( $V_{FB}$ ) vs. Temperature, Normalized**

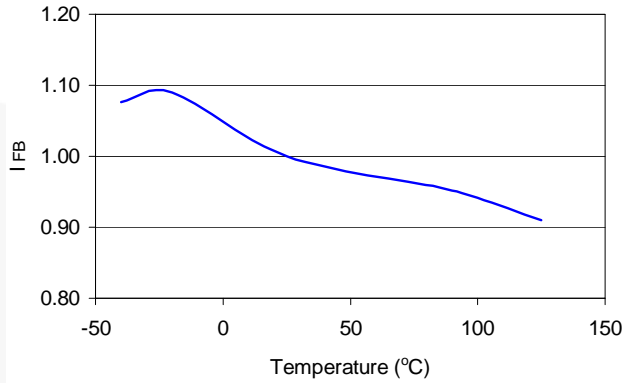

**Figure 5. Reference Bias Current ( $I_{FB}$ ) vs. Temperature, Normalized**

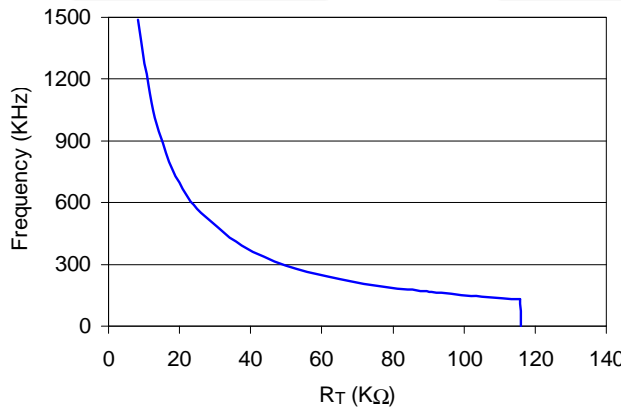

**Figure 6. Frequency vs.  $R_T$**

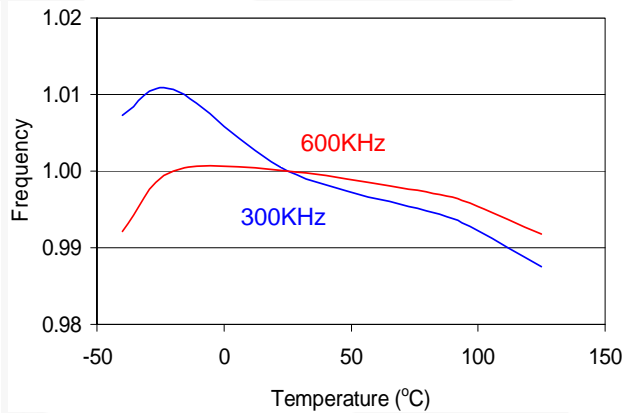

**Figure 7. Frequency vs. Temperature, Normalized**

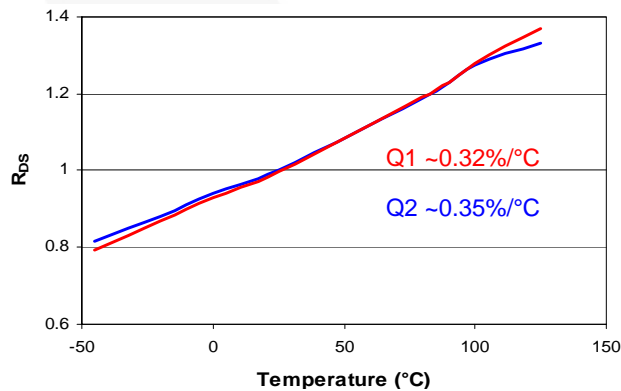

**Figure 8.  $R_{DS}$  vs. Temperature, Normalized ( $V_{CC}=V_{GS}=5$  V), Figure 1**

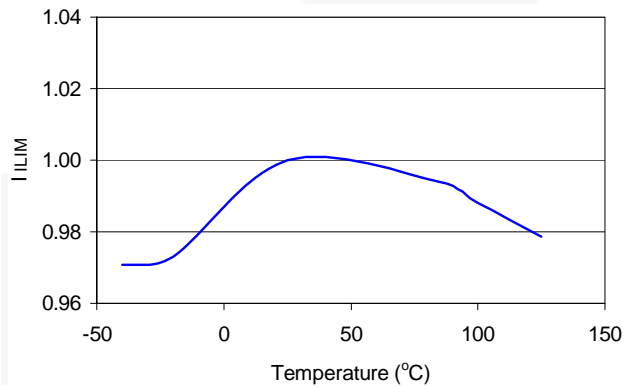

**Figure 9.  $I_{LIM}$  Current ( $I_{LIM}$ ) vs. Temperature, Normalized**





## Typical Performance Characteristics

Typical operating characteristics using the circuit in Figure 10.  $V_{IN}=12\text{ V}$ ,  $V_{CC}=5\text{ V}$ ,  $T_A=25^\circ\text{C}$ , unless otherwise specified.

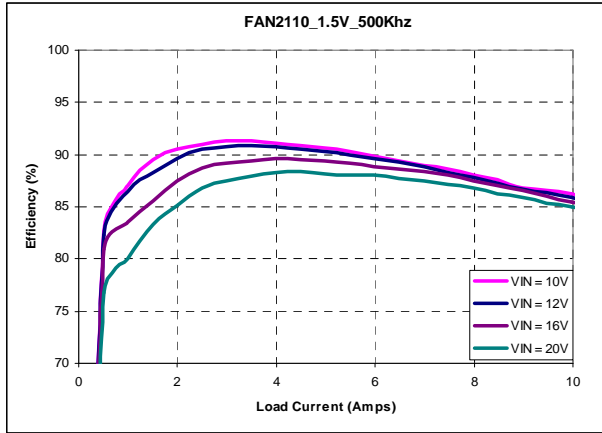

Figure 12. 1.5  $V_{OUT}$  Efficiency, 500 KHz

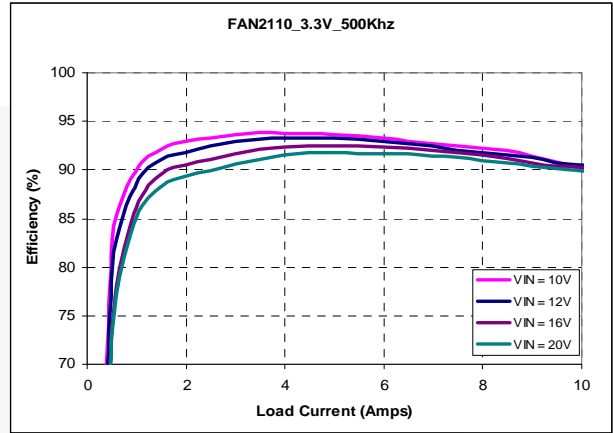

Figure 13. 3.3  $V_{OUT}$  Efficiency, 500 KHz<sup>(4)</sup>

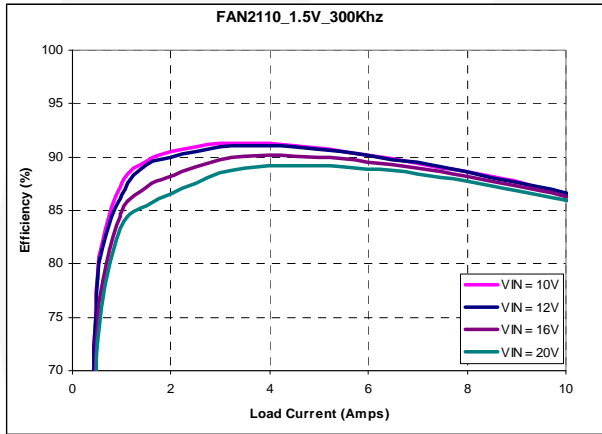

Figure 14. 1.5  $V_{OUT}$  Efficiency, 300 KHz

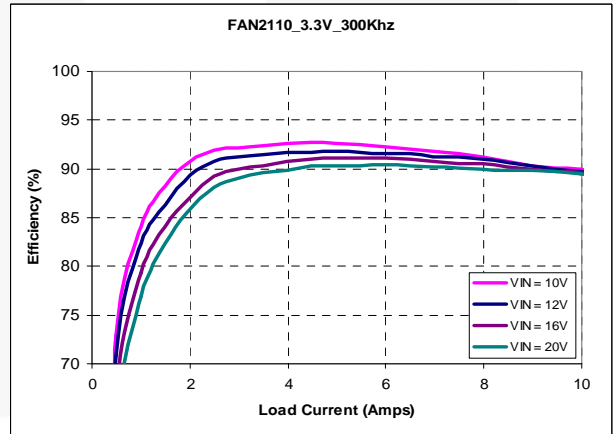

Figure 15. 3.3  $V_{OUT}$  Efficiency, 300 KHz<sup>(4)</sup>

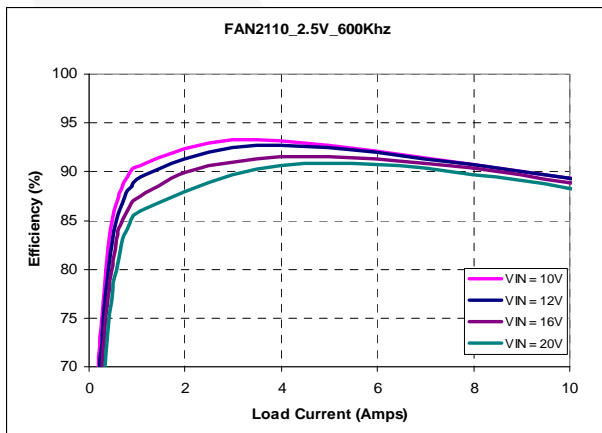

Figure 16. 2.5  $V_{OUT}$  Efficiency, 600 KHz<sup>(4)</sup>

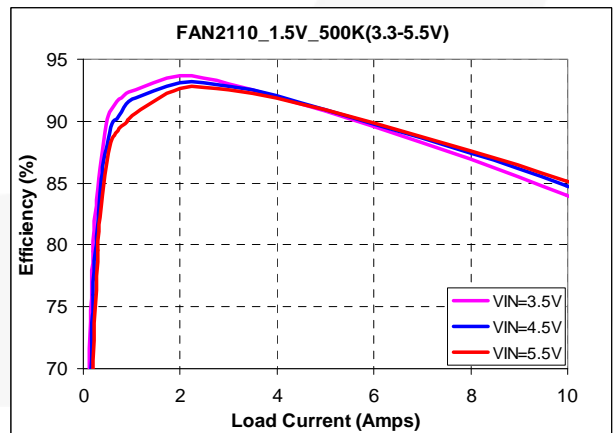

Figure 17. 1.5  $V_{OUT}$  Efficiency, 500 KHz ( $V_{IN}=3.3\text{ V to }5\text{ V}$ ), Figure 11

### Note:

- Circuit values for this configuration change in Figure 10.

## Typical Performance Characteristics (Continued)

Typical operating characteristics using the circuit in Figure 10.  $V_{IN}=12\text{ V}$ ,  $V_{CC}=5\text{ V}$ ,  $T_A=25^\circ\text{C}$  unless otherwise specified.

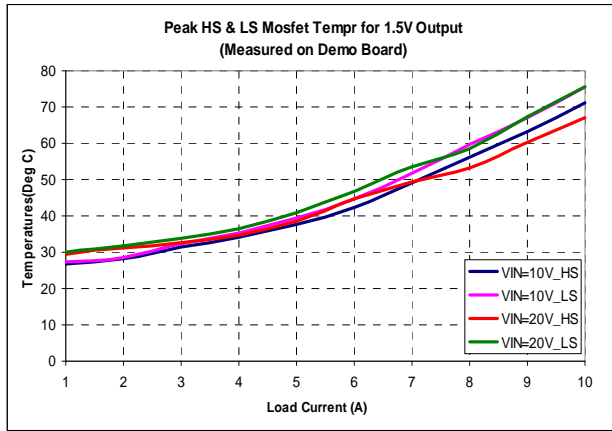

Figure 18. Peak MOSFET Temperatures, Figure 10

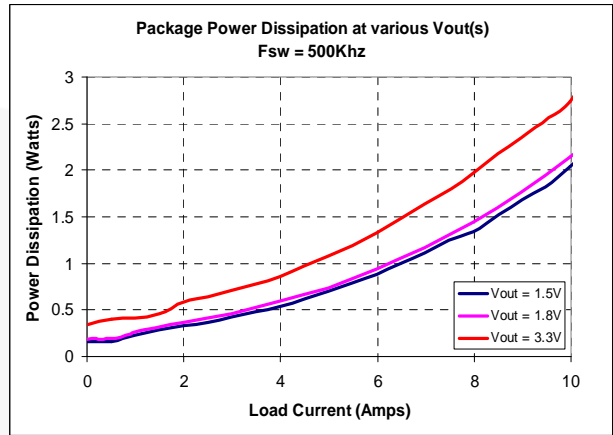

Figure 19. Device Dissipation Over  $V_{OUT}$  vs. Load

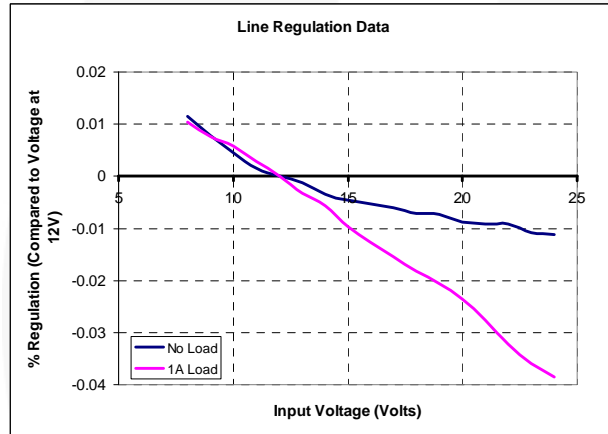

Figure 20. 1.5  $V_{OUT}$  Line Regulation

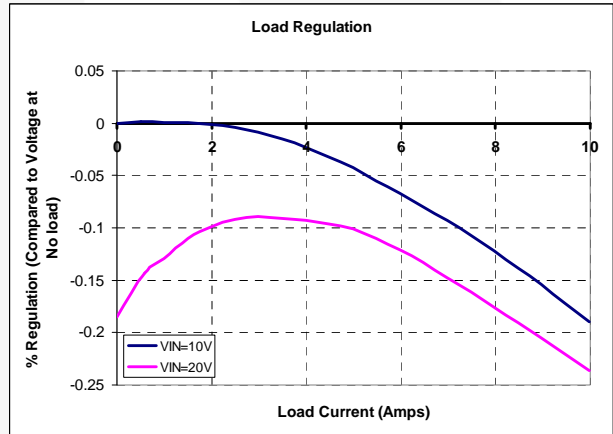

Figure 21. 1.5  $V_{OUT}$  Load Regulation

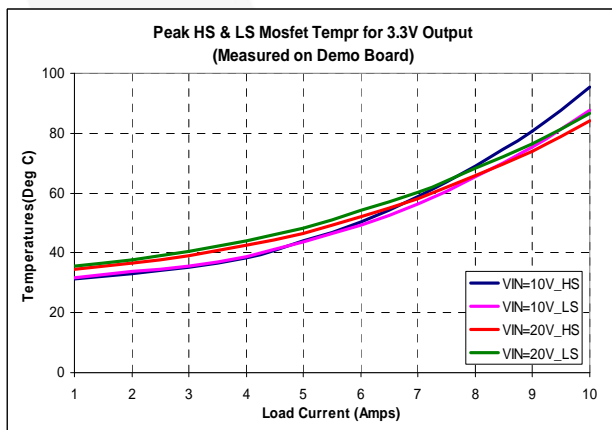

Figure 22. Peak MOSFET Temperatures, 3.3 V Output<sup>(5)</sup>

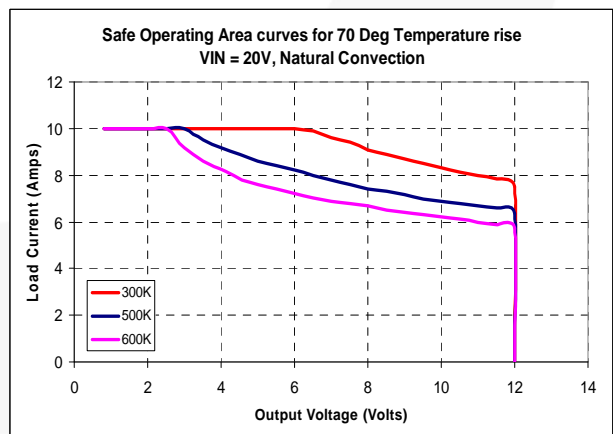

Figure 23. Typical 20  $V_{IN}$  Safe Operation Area (SOA), 70°C Ambient Temperature, Natural Convection

**Note:**

5. Circuit values for this configuration change in Figure 10.

## Typical Performance Characteristics (Continued)

Typical operating characteristics using the circuit in Figure 10.  $V_{IN}=12\text{ V}$ ,  $V_{CC}=5\text{ V}$ ,  $T_A=25^\circ\text{C}$  unless otherwise specified.

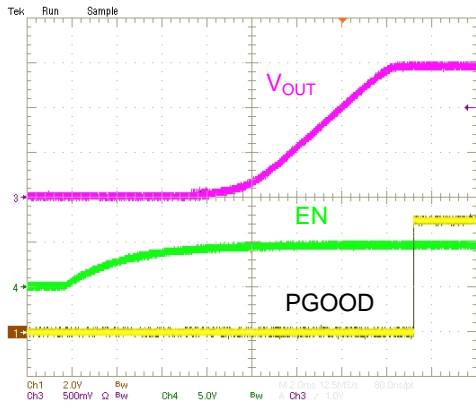

Figure 24. Startup, 10 A Load

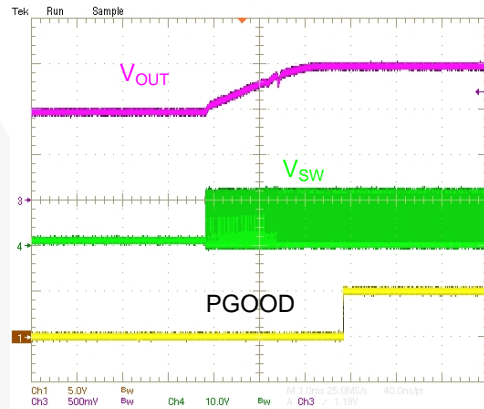

Figure 25. Startup with 1.0 V Pre-Bias on  $V_{OUT}$

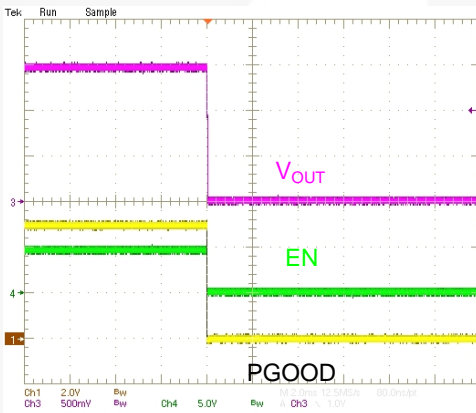

Figure 26. Shutdown, 10 A Resistive Load

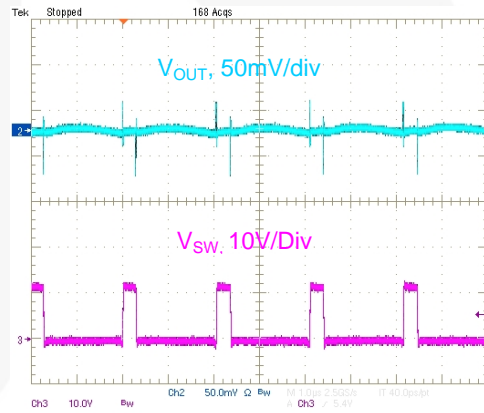

Figure 27.  $V_{OUT}$  Ripple and SW Voltage, 10 A Load

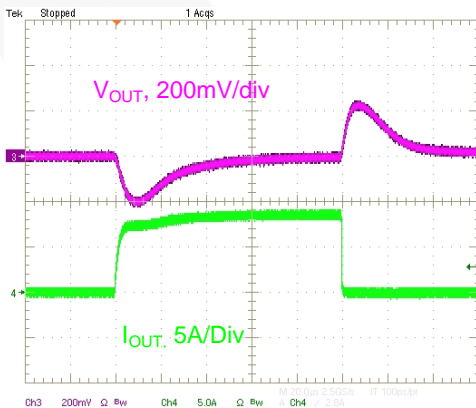

Figure 28. Transient Response, 0-8 A Load, 5 A /  $\mu\text{s}$  Slew Rate

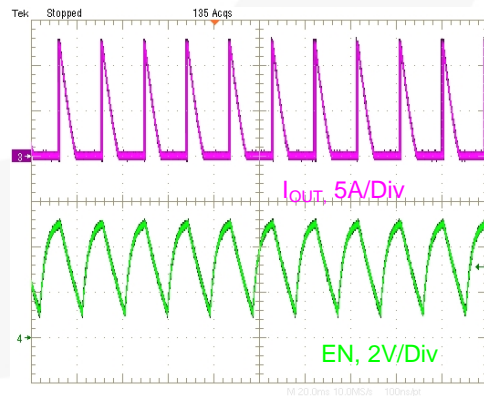

Figure 29. Restart on Short Circuit (Fault)

## Circuit Description

### PWM Generation

Refer to Figure 2 for the PWM control mechanism. FAN2110 uses the summing-mode method of control to generate the PWM pulses. An amplified current-sense signal is summed with an internally generated ramp and the combined signal is compared with the output of the error amplifier to generate the pulse width to drive the high-side MOSFET. Sensed current from the previous cycle is used to modulate the output of the summing block. The output of the summing block is also compared against a voltage threshold set by the  $R_{LIM}$  resistor to limit the inductor current on a cycle-by-cycle basis.  $R_{RAMP}$  resistor helps set the charging current for the internal ramp and provides input voltage feed-forward function. The controller facilitates external compensation for enhanced flexibility.

### Initialization

Once  $V_{CC}$  exceeds the UVLO threshold and EN is HIGH, the IC checks for a shorted FB pin before releasing the internal soft-start ramp (SS).

If the parallel combination of  $R_1$  and  $R_{BIAS}$  is  $\leq 1\text{ K}\Omega$ , the internal SS ramp is not released and the regulator does not start.

### Enable

FAN2110 has an internal pull-up to the enable (EN) pin so that the IC is enabled once  $V_{CC}$  exceeds the UVLO threshold. Connecting a small capacitor across EN and AGND delays the rate of voltage rise on the EN pin. The EN pin also serves for the restart whenever a fault occurs (refer to the *Auto-Restart* section). If the regulator is enabled externally, the external EN signal should go HIGH only after  $V_{CC}$  is established. For applications where such sequencing is required, FAN2110 can be enabled (after the  $V_{CC}$  comes up) with external control, as shown in Figure 30.

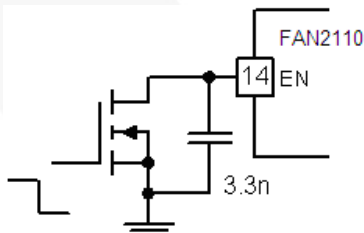

Figure 30. Enabling with External Control

### Soft-Start

Once internal SS ramp has charged to 0.8 V ( $T_{0.8}$ ), the output voltage is in regulation. Until SS ramp reaches 1.0 V ( $T_{1.0}$ ), the fault latch is inhibited.

To avoid skipping the soft-start cycle, it is necessary to apply  $V_{IN}$  before  $V_{CC}$  reaches its UVLO threshold. Normal sequence for powering up would be  $V_{IN} \rightarrow V_{CC} \rightarrow EN$ .

Soft-start time is a function of oscillator frequency.

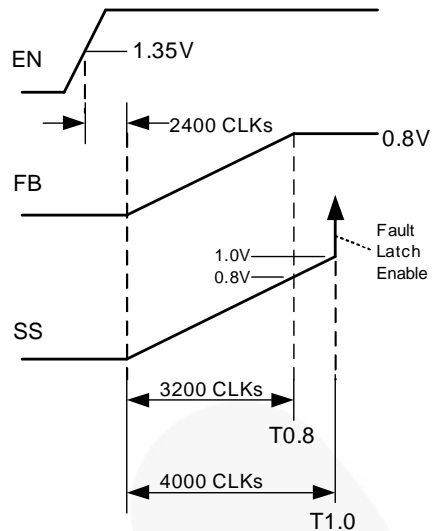

Figure 31. Soft-Start Timing Diagram

$V_{CC}$  UVLO or toggling the EN pin discharges the internal SS and resets the IC. In applications where external EN signal is used,  $V_{IN}$  and  $V_{CC}$  should be established before the EN signal comes up to prevent skipping the soft-start function.

### Startup on Pre-Bias

The regulator does not allow the low-side MOSFET to operate in full synchronous mode until SS reaches 95% of  $V_{REF}$  ( $\sim 0.76\text{ V}$ ). This enables the regulator to startup on a pre-biased output and ensures that pre-biased outputs are not discharged during the soft-start cycle.

### Protections

The converter output is monitored and protected against extreme overload, short-circuit, over-voltage, under-voltage, and over-temperature conditions.

### Under-Voltage Shutdown

If voltage on the FB pin remains below the under-voltage threshold for 16 consecutive clock cycles, the fault latch is set and the converter shuts down. This protection is not active until the internal SS ramp reaches 1.0 V during soft-start.

### Over-Voltage Protection

If voltage on the FB pin exceeds 115% of  $V_{REF}$  for two consecutive clock cycles, the fault latch is set and shutdown occurs.

A shorted high-side MOSFET condition is detected when SW voltage exceeds  $\sim 0.7$  V while the low-side MOSFET is fully enhanced. The fault latch is set immediately upon detection.

The OV/UV fault protection circuits above are active all the time, including during soft-start.

### Over-Temperature Protection (OTP)

The chip incorporates an over-temperature protection circuit that sets the fault latch when a die temperature of about  $150^{\circ}\text{C}$  is reached. The IC restarts when the die temperature falls below  $125^{\circ}\text{C}$ .

### Auto-Restart

After a fault, EN pin is discharged by a  $1\ \mu\text{A}$  current sink to a 1.1 V threshold before the internal  $800\ \text{K}\Omega$  pull-up is restored. A new soft-start cycle begins when EN charges above 1.35 V.

Depending on the external circuit, the FAN2110 can be configured to remain latched-off or to automatically restart after a fault.

**Table 1. Fault / Restart Configurations**

EN Pin	Controller / Restart State
Pull to GND	OFF (Disabled)
Pull-up to $V_{CC}$ with 100K	No Restart – Latched OFF (After $V_{CC}$ Comes Up)
Open	Immediate Restart After Fault
Cap. to GND	New Soft-Start Cycle After: $t_{DELAY}(\text{ms}) = 3.9 \cdot C(\text{nf})$

When EN is left open, restart is immediate.

If auto-restart is not desired, tie the EN pin to the VCC pin or pull it HIGH after  $V_{CC}$  comes up with a logic gate to keep the  $1\ \mu\text{A}$  current sink from discharging EN to 1.1V. Figure 32 shows one method to pull up EN to  $V_{CC}$  for a latch configuration.

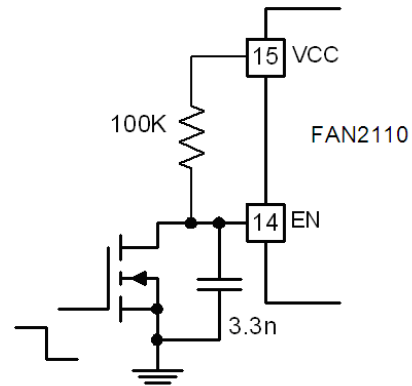

**Figure 32. Enable Control with Latch Option**

### Power-Good (PGOOD) Signal

PGOOD is an open-drain output that asserts LOW when  $V_{OUT}$  is out of regulation, as measured at the FB pin. Thresholds are specified in the Electrical Specifications section. PGOOD does not assert HIGH until the fault latch is enabled (T1.0) (see Figure 31).

## Application Information

### Bias Supply

The FAN2110 requires a 5 V supply rail to bias the IC and provide gate-drive energy. Connect a  $\geq 2.2 \mu\text{F}$  X5R or X7R decoupling capacitor between VCC and AGND.

Since  $V_{CC}$  is used to drive the internal MOSFET gates, supply current is frequency and voltage dependent. Approximate  $V_{CC}$  current ( $I_{CC}$ ) is calculated by:

$$I_{CC(mA)} = 4.58 + \left[ \left( \frac{V_{CC} - 5}{227} + 0.013 \right) \cdot (f - 128) \right] \quad (1)$$

where frequency (f) is expressed in KHz.

### Setting the Output Voltage

The output voltage of the regulator can be set from 0.8V to 80% of  $V_{IN}$  by an external resistor divider ( $R_1$  and  $R_{BIAS}$  in Figure 1). For output voltages  $>3.3\text{V}$ , output current rating may need to be de-rated depending on the ambient temperature, power dissipated in the package and the PCB layout. (Refer to Thermal Information table on page 4, Figure 22, and Figure 23.)

The external resistor divider is calculated using:

$$\frac{0.8V}{R_{BIAS}} = \frac{V_{OUT} - 0.8V}{R_1} + 650nA \quad (1)$$

Connect  $R_{BIAS}$  between FB and AGND.

If  $R_1$  is open (see Figure 1), the output voltage is not regulated and a latched fault occurs after the SS is complete (T1.0).

If the parallel combination of  $R_1$  and  $R_{BIAS}$  is  $\leq 1\text{K}\Omega$ , the internal SS ramp is not released and the regulator does not start.

### Setting the Clock Frequency

Oscillator frequency is determined by an external resistor,  $R_T$ , connected between the  $R_T$  pin and AGND. Resistance is calculated by:

$$R_T(K\Omega) = \frac{(10^6 / f) - 135}{65} \quad (2)$$

where  $R_T$  is in  $\text{K}\Omega$  and frequency (f) is in KHz.

The regulator cannot start if  $R_T$  is left open.

### Calculating the Inductor Value

Typically the inductor value is chosen based on ripple current ( $\Delta I_L$ ), which is chosen between 10 to 35% of the maximum DC load. Regulator designs that require fast transient response use a higher ripple-current setting, while regulator designs that require higher efficiency keep ripple current on the low side and

operate at a lower switching frequency. The inductor value is calculated by the following formula:

$$L = \frac{V_{OUT} \cdot \left( 1 - \frac{V_{OUT}}{V_{IN}} \right)}{\Delta I_L \cdot f} \quad (3)$$

where f is the oscillator frequency.

### Setting the Ramp Resistor Value

$R_{RAMP}$  resistor plays a critical role in the design by providing charging current to the internal ramp capacitor and also serving as a means to provide input voltage feedforward.

$R_{RAMP}$  is calculated by the following formula:

$$R_{RAMP(K\Omega)} = \frac{(V_{IN} - 1.8) \cdot V_{OUT}}{(31 - 2.05 \cdot I_{OUT}) \cdot V_{IN} \cdot f \cdot 10^{-6}} - 2 \quad (4)$$

where frequency (f) is expressed in KHz.

For wide input operation, first calculate  $R_{RAMP}$  for the minimum and maximum input voltage conditions and use larger of the two values calculated.

In all applications, current through the  $R_{RAMP}$  pin must be greater than  $10 \mu\text{A}$  from the equation below for proper operation:

$$\frac{V_{IN} - 1.8}{R_{RAMP} + 2} \geq 10 \mu\text{A} \quad (5)$$

If the calculated  $R_{RAMP}$  values in Equation (5) result in a current less than  $10 \mu\text{A}$ , use the  $R_{RAMP}$  value that satisfies Equation (6). In applications with large input ripple voltage, the  $R_{RAMP}$  resistor should be adequately decoupled from the input voltage to minimize ripple on the ramp pin. For example, see Figure 11.

### Setting the Current Limit

The current limit system involves two comparators. The MAX  $I_{LIMIT}$  comparator is used with a  $V_{LIM}$  fixed-voltage reference and represents the maximum current limit allowable. This reference voltage is temperature compensated to reflect the  $R_{DS(on)}$  variation of the low-side MOSFET. The ADJUST  $I_{LIMIT}$  comparator is used where the current limit needs to be set lower than the  $V_{LIM}$  fixed reference. The  $10 \mu\text{A}$  current source does not track the  $R_{DS(on)}$  changes over temperature, so change is added into the equations for calculating the ADJUST  $I_{LIMIT}$  comparator reference voltage, as is shown below. Figure 33 shows a simplified schematic of the over-current system.

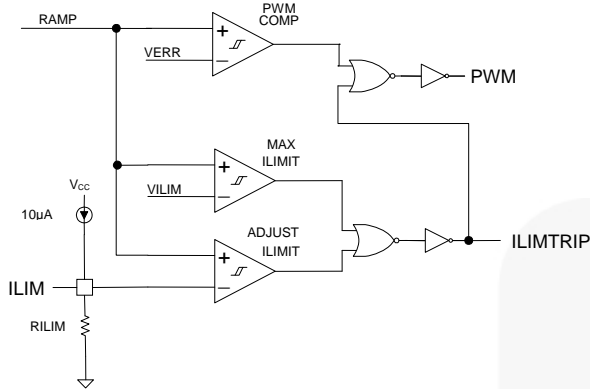

**Figure 33. Current-Limit System Schematic**

Since the  $I_{LIM}$  voltage is set by a  $10\ \mu\text{A}$  current source into the  $R_{ILIM}$  resistor, the basic equation for setting the reference voltage is:

$$V_{RILIM} = 10\ \mu\text{A} \cdot R_{ILIM} \quad (6)$$

To calculate  $R_{ILIM}$ :

$$R_{ILIM} = V_{RILIM} / 10\ \mu\text{A} \quad (7)$$

The voltage  $V_{RILIM}$  is made up of two components,  $V_{BOT}$  (which relates to the current through the low-side MOSFET) and  $V_{RMPEAK}$  (which relates to the peak current through the inductor). Combining those two voltage terms results in:

$$R_{ILIM} = (V_{BOT} + V_{RMPEAK}) / 10\ \mu\text{A} \quad (8)$$

$$R_{ILIM} = \{0.96 + (I_{LOAD} \cdot R_{DSON} \cdot K_T \cdot 8)\} + \{D \cdot (V_{IN} - 1.8) / (f_{SW} \cdot 0.03 \cdot R_{RAMP})\} / 10\ \mu\text{A} \quad (9)$$

where:

$$V_{BOT} = 0.96 + (I_{LOAD} \cdot R_{DSON} \cdot K_T \cdot 8);$$

$$V_{RMPEAK} = D \cdot (V_{IN} - 1.8) / (f_{SW} \cdot 0.03 \cdot R_{RAMP});$$

$I_{LOAD}$  = the desired maximum load current;

$R_{DSON}$  = the nominal  $R_{DSON}$  of the low-side MOSFET;

$K_T$  = the normalized temperature coefficient for the low-side MOSFET (on datasheet graph);

$D = V_{OUT} / V_{IN}$  duty cycle;

$f_{SW}$  = Clock frequency in kHz; and

$R_{RAMP}$  = chosen ramp resistor value in k $\Omega$ .

After 16 consecutive, pulse-by-pulse, current-limit cycles, the fault latch is set and the regulator shuts down. Cycling  $V_{CC}$  or EN restores operation after a normal soft-start cycle (refer to the *Auto-Restart* section).

The over-current protection fault latch is active during the soft-start cycle. Use 1% resistor for  $R_{ILIM}$ .

Always use an external resistor  $R_{ILIM}$  to set the current limit at the desired level. When  $R_{ILIM}$  is not connected,

the IC's internal default current limit is fairly high. This could lead to operation at high load currents, causing overheating of the regulator. For a given  $R_{ILIM}$  and  $R_{RAMP}$  setting, the current limit point varies slightly in an inverse relationship with respect to input voltage ( $V_{IN}$ ).

### Loop Compensation

The loop is compensated using a feedback network around the error amplifier. Figure 34 shows a complete type-3 compensation network. For type-2 compensation, eliminate  $R_3$  and  $C_3$ .

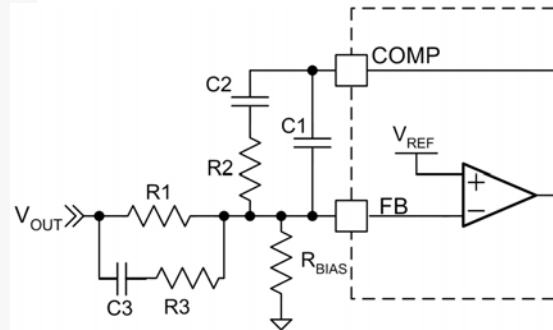

**Figure 34. Compensation Network**

Since the FAN2110 employs summing current-mode architecture, type-2 compensation can be used for many applications. For applications that require wide loop bandwidth and/or use very low-ESR output capacitors, type-3 compensation may be required.

$R_{RAMP}$  also provides feedforward compensation for changes in  $V_{IN}$ . With a fixed  $R_{RAMP}$  value, the modulator gain increases as  $V_{IN}$  is reduced, which could make it difficult to compensate the loop. For low-input-voltage-range designs (3 V to 8 V),  $R_{RAMP}$  and the compensation component values are different compared to designs with  $V_{IN}$  between 8 V and 24 V.

### Recommended PCB Layout

Good PCB layout and careful attention to temperature rise is essential for reliable operation of the regulator. Four-layer PCB with two-ounce copper on the top and bottom side and thermal vias connecting the layers is recommended. Keep power traces wide and short to minimize losses and ringing. Do not connect AGND to PGND below the IC. Connect the AGND pin to PGND at the output OR to the PGND plane.

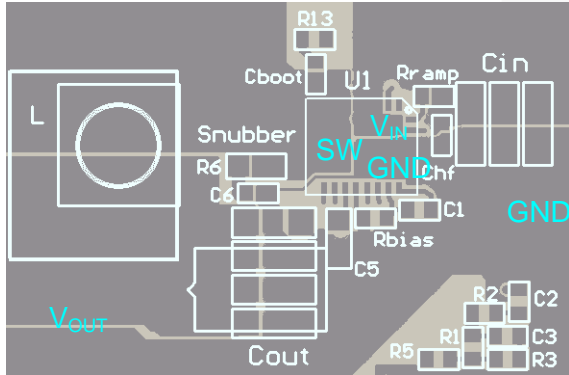
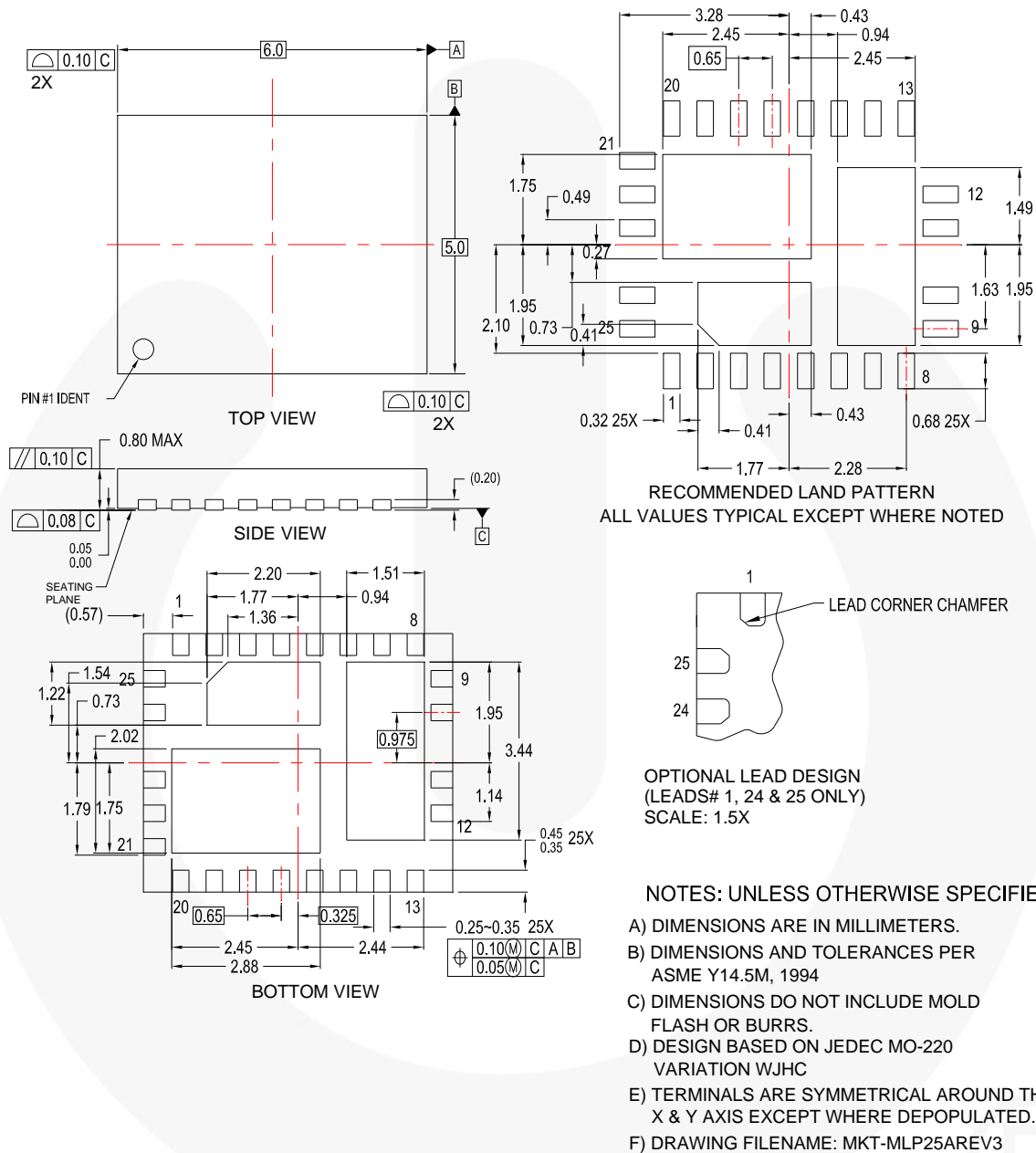

Figure 35. Recommended PCB Layout



## Physical Dimensions



**Figure 36. 5x6 mm Molded Leadless Package (MLP)**

Package drawings are provided as a service to customers considering Fairchild components. Drawings may change in any manner without notice. Please note the revision and/or date on the drawing and contact a Fairchild Semiconductor representative to verify or obtain the most recent revision. Package specifications do not expand the terms of Fairchild's worldwide terms and conditions, specifically the warranty therein, which covers Fairchild products.

Always visit Fairchild Semiconductor's online packaging area for the most recent package drawings:  
<http://www.fairchildsemi.com/packaging/>.



### TRADEMARKS

The following includes registered and unregistered trademarks and service marks, owned by Fairchild Semiconductor and/or its global subsidiaries, and is not intended to be an exhaustive list of all such trademarks.

2Cool™	F-PFS™	PowerTrench®	The Power Franchise®
AccuPower™	FRFET®	PowerXS™	<b>the power franchise</b>
AX-CAP™*	Global Power Resource™	Programmable Active Droop™	TinyBoost™
BitSiC™	GreenBridge™	QFET®	TinyBuck™
Build it Now™	Green FPS™	QS™	TinyCalc™
CorePLUS™	Green FPS™ e-Series™	Quiet Series™	TinyLogic®
CorePOWER™	Gmax™	RapidConfigure™	TINYOPTO™
CROSSVOLT™	GTO™	 ™	TinyPower™
CTL™	IntelliMAX™	Saving our world, 1mW/kW at a time™	TinyPWM™
Current Transfer Logic™	ISOPLANAR™	SignalWise™	TinyWire™
DEUXPEED®	Making Small Speakers Sound Louder and Better™	SmartMax™	TranSiC™
Dual Cool™	MegaBuck™	SMART START™	TriFault Detect™
EcoSPARK®	MICROCOUPLER™	Solutions for Your Success™	TRUECURRENT®*
EfficientMax™	MicroFET™	SPM®	µSerDes™
ESBC™	MicroPak™	STEALTH™	 SerDes™
<b>F</b> ®	MicroPak2™	SuperFET®	UHC™
Fairchild®	MillerDrive™	SuperSOT™-3	Ultra FRFET™
Fairchild Semiconductor®	MotionMax™	SuperSOT™-6	UniFET™
FACT Quiet Series™	mWSaver™	SuperSOT™-8	VCX™
FACT®	OptoHi™	SupreMOS®	VisualMax™
FAST®	OPTOLOGIC®	SyncFET™	VoltagePlus™
FastvCore™	OPTOPLANAR®	Sync-Lock™	XS™
FETBench™		 SYSTEM GENERAL®*	
FlashWriter®*			
FPS™			

\* Trademarks of System General Corporation, used under license by Fairchild Semiconductor.

### DISCLAIMER

FAIRCHILD SEMICONDUCTOR RESERVES THE RIGHT TO MAKE CHANGES WITHOUT FURTHER NOTICE TO ANY PRODUCTS HEREIN TO IMPROVE RELIABILITY, FUNCTION, OR DESIGN. FAIRCHILD DOES NOT ASSUME ANY LIABILITY ARISING OUT OF THE APPLICATION OR USE OF ANY PRODUCT OR CIRCUIT DESCRIBED HEREIN; NEITHER DOES IT CONVEY ANY LICENSE UNDER ITS PATENT RIGHTS, NOR THE RIGHTS OF OTHERS. THESE SPECIFICATIONS DO NOT EXPAND THE TERMS OF FAIRCHILD'S WORLDWIDE TERMS AND CONDITIONS, SPECIFICALLY THE WARRANTY THEREIN, WHICH COVERS THESE PRODUCTS.

### LIFE SUPPORT POLICY

FAIRCHILD'S PRODUCTS ARE NOT AUTHORIZED FOR USE AS CRITICAL COMPONENTS IN LIFE SUPPORT DEVICES OR SYSTEMS WITHOUT THE EXPRESS WRITTEN APPROVAL OF FAIRCHILD SEMICONDUCTOR CORPORATION.

As used herein:

1. Life support devices or systems are devices or systems which, (a) are intended for surgical implant into the body or (b) support or sustain life, and (c) whose failure to perform when properly used in accordance with instructions for use provided in the labeling, can be reasonably expected to result in a significant injury of the user.
2. A critical component in any component of a life support, device, or system whose failure to perform can be reasonably expected to cause the failure of the life support device or system, or to affect its safety or effectiveness.

### ANTI-COUNTERFEITING POLICY

Fairchild Semiconductor Corporation's Anti-Counterfeiting Policy. Fairchild's Anti-Counterfeiting Policy is also stated on our external website, [www.fairchildsemi.com](http://www.fairchildsemi.com), under Sales Support.

Counterfeiting of semiconductor parts is a growing problem in the industry. All manufacturers of semiconductor products are experiencing counterfeiting of their parts. Customers who inadvertently purchase counterfeit parts experience many problems such as loss of brand reputation, substandard performance, failed applications, and increased cost of production and manufacturing delays. Fairchild is taking strong measures to protect ourselves and our customers from the proliferation of counterfeit parts. Fairchild strongly encourages customers to purchase Fairchild parts either directly from Fairchild or from Authorized Fairchild Distributors who are listed by country on our web page cited above. Products customers buy either from Fairchild directly or from Authorized Fairchild Distributors are genuine parts, have full traceability, meet Fairchild's quality standards for handling and storage and provide access to Fairchild's full range of up-to-date technical and product information. Fairchild and our Authorized Distributors will stand behind all warranties and will appropriately address any warranty issues that may arise. Fairchild will not provide any warranty coverage or other assistance for parts bought from Unauthorized Sources. Fairchild is committed to combat this global problem and encourage our customers to do their part in stopping this practice by buying direct or from authorized distributors.

### PRODUCT STATUS DEFINITIONS

#### Definition of Terms

Datasheet Identification	Product Status	Definition
Advance Information	Formative / In Design	Datasheet contains the design specifications for product development. Specifications may change in any manner without notice.
Preliminary	First Production	Datasheet contains preliminary data; supplementary data will be published at a later date. Fairchild Semiconductor reserves the right to make changes at any time without notice to improve design.
No Identification Needed	Full Production	Datasheet contains final specifications. Fairchild Semiconductor reserves the right to make changes at any time without notice to improve the design.
Obsolete	Not In Production	Datasheet contains specifications on a product that is discontinued by Fairchild Semiconductor. The datasheet is for reference information only.

Rev. I62