

SPECIFICATION

Device Name : M-Power

Type Name : F9223L-F219

Spec. No. : MS5F06456

This material and the information herein is the property of Fuji Electric Device Technology Co., Ltd. They shall be neither reproduced, copied, lent, or disclosed in any way whatsoever for the use of any third party nor used for the manufacturing purposes without the express written consent of Fuji Electric Device Technology Co., Ltd.

保守移行機種
 Not recommend for new design.

	DATE	NAME	APPROVED				
DRAWN	Oct.-18-'05	T. Shimatah		Fuji Electric Device Technology Co., Ltd. DWG. NO. MS5F06456			
CHECKED	Oct.-18-'05	T. HOSEN					
CHECKED	Oct.-18-'05	T. Kobara	T. Miyazaki				
				1/24 <table border="1" style="display: inline-table; width: 40px; height: 20px; vertical-align: middle;"> <tr><td> </td></tr> <tr><td> </td></tr> <tr><td> </td></tr> </table>			

Revised Records

DATE	CLASSI-FICATION	IND.	Content	Applied date	Drawn	Checkd	Checkd	Approved
Oct. 18.2005	Enactment	-	-	Issued date	-	T. HOSEN	T. Kobana	T. Miyasaka

This material and the information herein is the property of Fuji Electric Co.,Ltd. They shall be neither reproduced, copied, lent, or disclosed in any way whatsoever for the use of any third party nor used for the manufacturing purposes without the express written consent of Fuji Electric Co.,Ltd.

保守移行機種
Not recommend for new design.

1.Application

This specifies M-Power:F9223L-F219 applied to multi-oscillated current resonant type power supply.

2.Block diagram

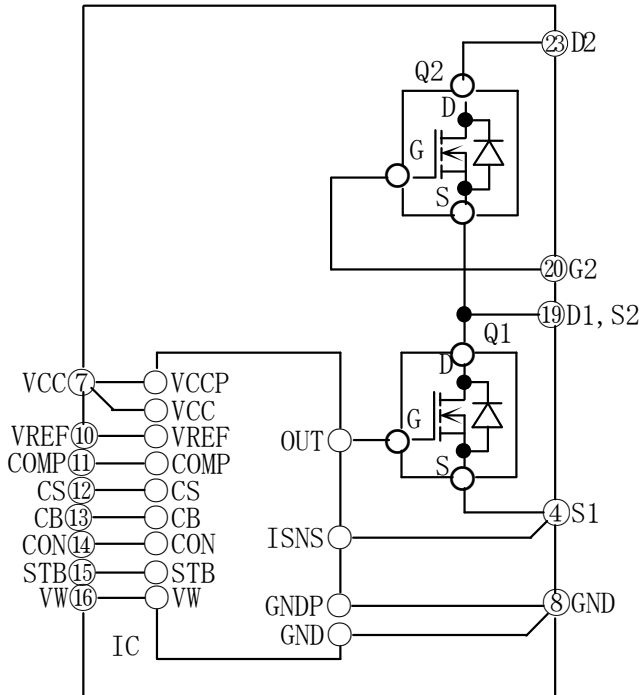

3.Pin disignation and function

Pin No.	Symbol	Function
4	S1	MOSFET(Q1) source
(5)		MOSFET(Q1) source current detection
7	VCC	Power supply
8	GND	Ground
(9)		MOSFET(Q1) source current detection ground
10	VREF	Reference voltage output
11	COMP	Input feedback signal for constant voltage control
12	CS	Soft-start and soft-end oscillation
13	CB	Burst oscillation
14	CON	Reference oscillation of Q1 on-term
15	STB	Standby operarion signal input
		Alarm output for latched-shutdown
16	VW	Q1 turn-on and off timing detection
19	D1,S2	Q1 drain and Q2 source
(1)(2)(18)		
20	G2	Q2 gate
23	D2	Q2 drain
(22)		

Note:

* Pins 3,17,and21 is cut.

* Pins 1,2,5,9,18,and22 no pin frames.

* Pin 6 is disconnected.

This pin is connectd to the Q1 gate but never connect it for waveform observation or any other purpose. Connection of the pin 6 could lead to major problems and could destroy the M-Power.

4. Control IC Block diagram

This material and the information herein is the property of Fuji Electric Device Technology Co.,Ltd. They shall be neither reproduced, copied, lent, or disclosed in any way whatsoever for the use of any third party nor used for the manufacturing purposes without the express written consent of Fuji Electric Device Technology Co.,Ltd.

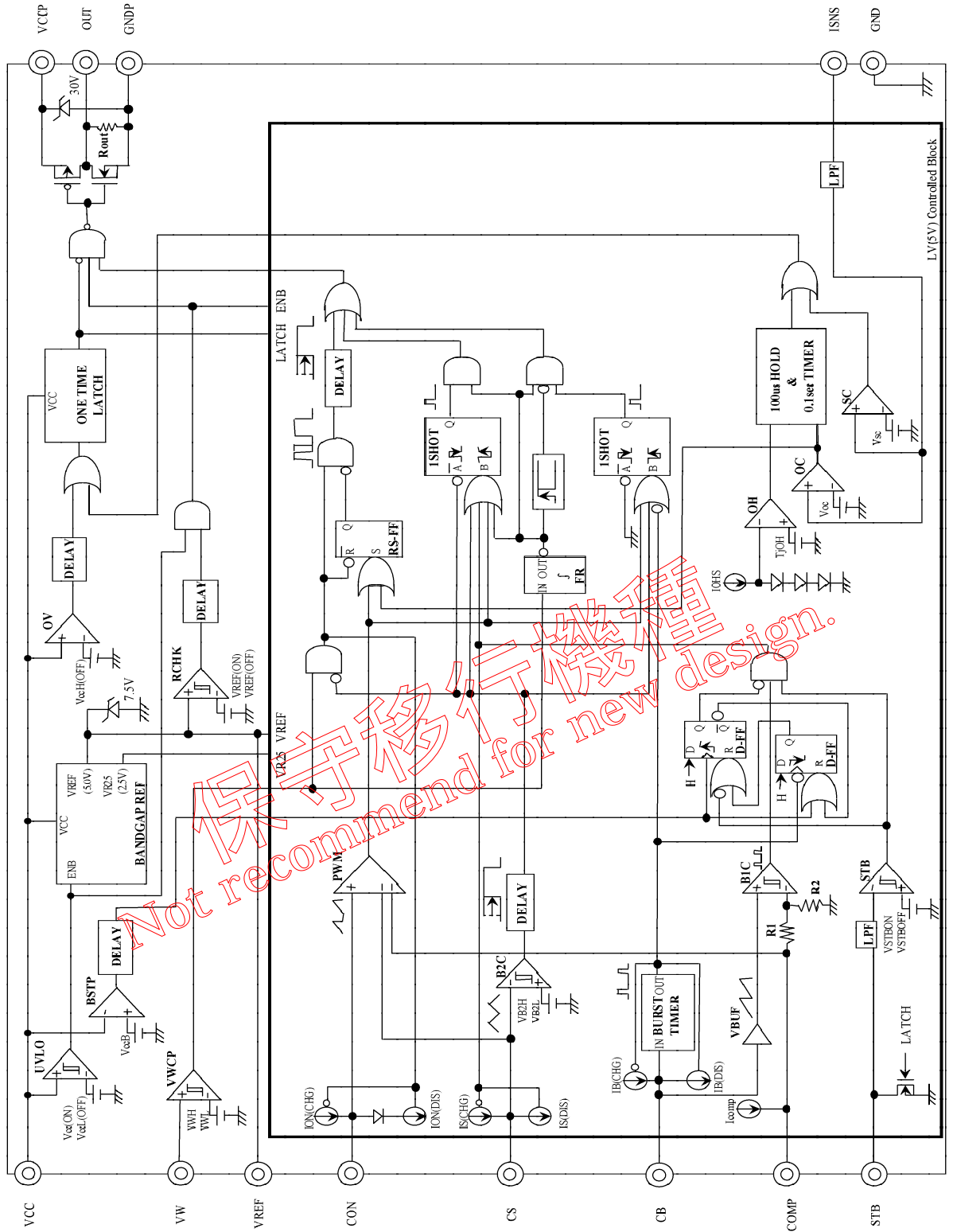

5.Out view

SIP23

フォーミング型式 : F219

Forming Type Name : F219

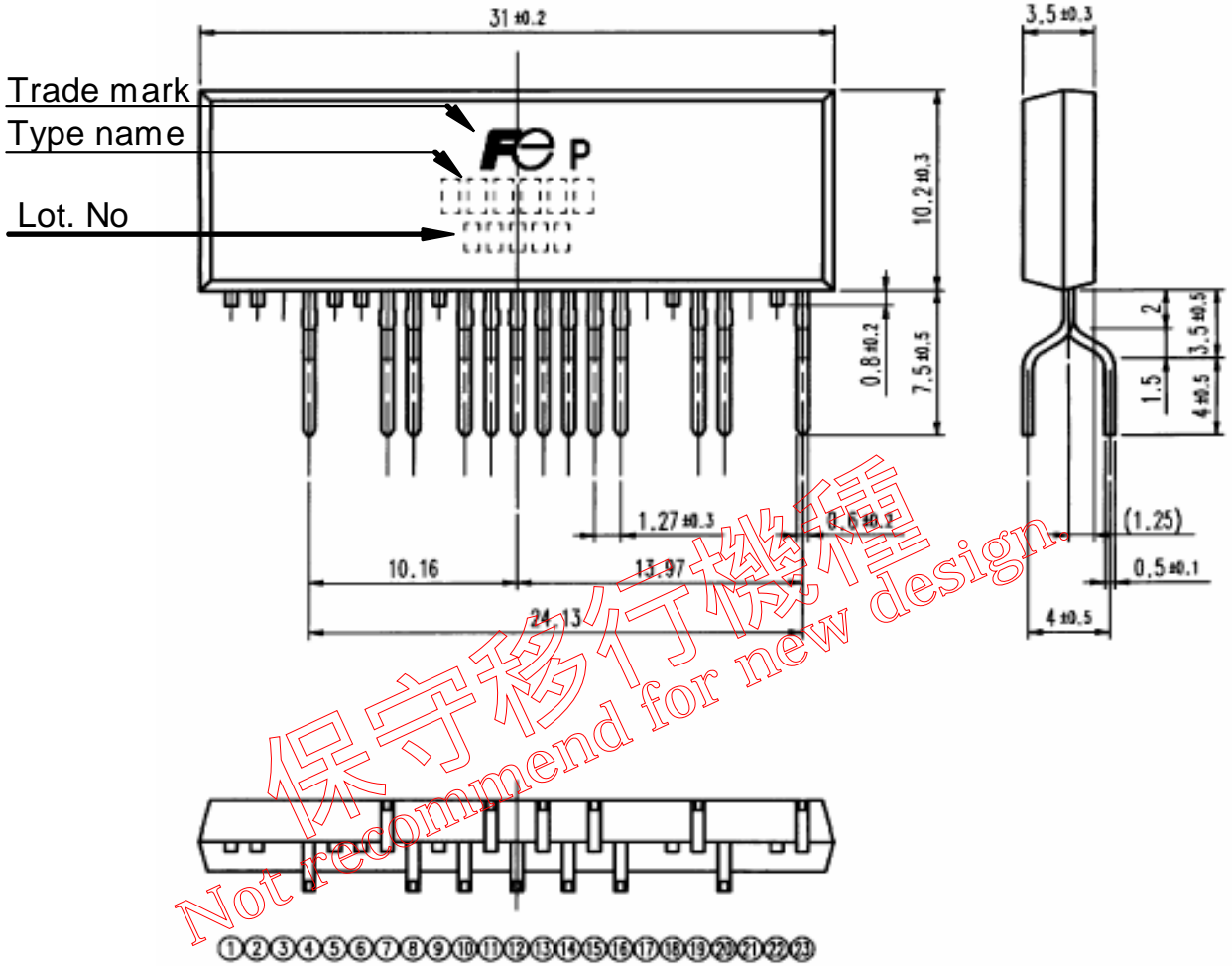

保守移行機種
Not recommend for new design

This material and the information herein is the property of Fuji Electric Device Technology Co.,Ltd. They shall be neither reproduced, copied, lent, or disclosed in any way whatsoever for the use of any third party nor used for the manufacturing purposes without the express written consent of Fuji Electric Device Technology Co.,Ltd.

寸法単位 (mm)
Dimension (mm)

6. Absolute maximum ratings : $V_{CC}=19V$, $T_c=T_j(IC)=T_{ch}(Q1,Q2)=25^{\circ}C$

Section	Item	Symbol	Ratings		Units	Remarks
			MIN	MAX		
MOS-FET	Drain-source voltage	V_{DS}	-1.5	+500	V	Q1 and Q2 Q1: 19-4 terminal Q2: 23-19 terminal
	Continuous drain current	I_D	-5.3	+5.3	A	
		I_{Dpulse}	-21.2	+21.2	A	
	Gate-source voltage	V_{GS}	-30	+30	V	
	Maximum power dissipation	P_D	-	35	W	
Control IC	Voltage	V_{CC1}	-0.3	+28	V	7-8terminal
		V_{CC2}	Self Limiting		V	
	Zener current	I_Z	0	+10	mA	
	Max.power dissipation	P_{DIC}	-	1.0	W	
	Output current at VREF	I_{REF}	-	20	mA	10-8 terminal
	Voltage at CON	V_{CON}	-0.3	V_{REF}	V	14-8 terminal
	Voltage at CB	V_{CB}	-0.3	V_{REF}	V	13-8 terminal
	Voltage at CS	V_{CS}	-0.3	V_{REF}	V	12-8 terminal
	Voltage at COMP	V_{COMP}	-0.3	V_{REF}	V	11-8 terminal
	Voltage at STB	V_{STB}	-0.3	V_{REF}	V	15-8 terminal
	Voltage at VW	V_W	-1.3	V_{CC}	V	16-8 terminal
	Voltage at S1	V_S	-1.0	V_{REF}	V	4-8 terminal
	Operating Frequency	F	15	150	kHz	16-8 terminal
Temperature	Operating temperature	T_c	-20	+125	$^{\circ}C$	
	Junction temperature	T_{ch}	-20	+150	$^{\circ}C$	
		T_j	-20	+150	$^{\circ}C$	
	Storage temperature	T_{stg}	-40	+150	$^{\circ}C$	

Note :

* The operating frequency in the absolute maximum rating is the operating frequency at normal operation. about the absolute maximum rating of operating frequency at standby operation, refer to the "Allowable frequency at standby operation curve" in 12/24 page.

* V_{CC} and V_{REF} in maximum ratings mean that it is necessary to make the applied voltage lower than the voltage of V_{CC} and a V_{REF} terminal. For example, if the voltage will be applied to the terminal at no V_{REF} voltage, it will be expected to latched shutdown.

This material and the information herein is the property of Fuji Electric Device Technology Co.,Ltd. They shall be neither reproduced, copied, lent, or disclosed in any way whatsoever for the use of any third party nor used for the manufacturing purposes without the express written consent of Fuji Electric Device Technology Co.,Ltd.

Not recommended for new design.

7. Electrical characteristics : $V_{CC}=19V$, $T_c=T_j(IC)=T_{ch}(Q1,Q2)=25^\circ C$

Section	Item	Symbol	Test condition	Rating			Units	Remarks
				MIN	TYP	MAX		
MOS-FET	Drain-source breakdown voltage	$B_{V_{DS}}$	$I_D=250\mu A, V_{GS}=0V$	500	-	-	V	Q1: 19-4 terminal
	Gate Threshold Voltage	$V_{GS(th)}$	$I_D=250\mu A, V_{DS}=V_{GS}$	3.5	4.0	4.5	V	
	Zero gate voltage drain current	I_{DSS}	$V_{DS}=500V, V_{GS}=0V$	-	-	25	μA	Q2: 23-19 terminal
	Drain-source on-state resistance	$R_{DS(ON)}$	$I_D=2.5A, V_{GS}=10V$	-	0.40	0.50	Ω	
	Input Capacitance	C_{iss}	$V_{DS}=25V$	-	1200	-	pF	
	Output Capacitance	C_{oss}	$V_{GS}=0V$	-	170	-	pF	
	Reverse Transfer Capacitance	C_{rss}	$f=1MHz$	-	9	-	pF	
	Turn-On Time	$t_{d(on)}$	$V_d=400V$	-	17.0	-	ns	
		t_r	$V_{GS}=10V$	-	10.0	-	ns	
		$t_{d(off)}$	$I_D=2.5A$	-	55.0	-	ns	
	Turn-Off Time	t_f	$R_{GS}=10\Omega$	-	28.0	-	ns	
		Diode Forward On-Voltage	V_{SD}	$I_F=10A, V_{GS}=0V$	-	1.0	1.5	
	Reverse Recovery Time	t_{rr}	$I_F=I_{DR}, V_{GS}=0V$	-	360	-	ns	
Reverse Recovery Charge	Q_{rr}	$-di_f/dt=100A/\mu s$	-	2.1	-	μC		
Control IC power supply	Start threshold voltage	$V_{CC(ON)}$		15.5	16.5	17.5	V	7-8 terminal
	Stop threshold voltage	$V_{CCL(OFF)}$		7.9	8.9	9.9	V	
	Hysteresis	V_{CCH}	$=V_{CC(ON)}-V_{CCL(OFF)}$	6.8	7.6	8.4	V	
	Cancellation voltage of burst operation	V_{CCB}		9.1	10.0	10.9	V	
	Hysteresis	V_{CCBH}	$=V_{CCB}-V_{CCL(OFF)}$	0.73	1.30	1.87	V	
	Over voltage threshold voltage	$V_{CCH(OFF)}$		24.0	26.0	28.0	V	
	Latch-stop cancellation voltage	$V_{CC(LA)}$		0.9	2.6	4.1	V	
	Operating current	I_{CC}	$F=75kHz$	7.5	9.0	10.5	mA	
	Zener voltage	V_Z	$I_{CC}=10mA$	28.0	30.0	34.0	V	
	Reference voltage	V_{REF}		4.7	5.0	5.3	V	
CON oscillation	Discharge current	$I_{ON(DIS)}$		6.5	9.1	11.7	mA	14-8 terminal
	Charge current	$I_{ON(CHG)}$		420	575	730	μA	
	Amplitude of CON voltage	V_{ONLH}		2.7	3.2	3.7	V	
	Maximum voltage	$V_{ON(MAX)}$		3.5	3.9	4.3	V	
CB oscillation	Discharge current	$I_{B(DIS)}$		8.4	11.2	14.0	mA	13-8 terminal
	Charge current	$I_{B(CHG)}$		40	52	64	μA	
	Amplitude of CB voltage	V_{BLH}		0.70	0.85	1.00	V	
CS oscillation	Discharge current	$I_{S(DIS)}$		79	105	131	μA	12-8 terminal
	Charge current	$I_{S(CHG)}$		83	109	139	μA	
	Start threshold voltage of Q1 switching	V_{BZH}		0.63	0.71	0.79	V	
	Stop threshold voltage of Q1 switching	V_{BZL}		0.54	0.63	0.72	V	
Feedback (COMP)	Stop voltage	V_{COMP}		0.61	0.71	0.81	V	11-8 terminal
	Source current	I_{COMP}		0.65	0.95	1.25	mA	
Standby(STB)	Standby threshold voltage	V_{STBON}		0.85	1.10	1.35	V	15-8 terminal
	Internal resistance at latched-shutdown	R_{STB}		100	220	340	Ω	
	Internal resistance at latched-shutdown	R_{STBOFF}		2.75	3.10	3.45	V	
Timing detection(VW)	Q1 turn-on threshold voltage	V_{WH}		0.65	0.78	0.91	V	16-8 terminal
	Q1 turn-off threshold voltage	V_{WL}		0.45	0.58	0.71	V	
Over current protection	Over current operating voltage	V_{OC}		0.83	0.90	0.97	V	4-8 terminal
	Operating time to Latched-shutdown	t_{dLA}		0.07	0.10	0.13	s	
	Reset time	t_{dLAR}		70	100	130	μs	
	Short-circuit current limiting voltage	V_{SC}		1.2	1.5	1.8	V	
Overheating protection	Operating temperature	T_{JOH}		125	-	150	$^\circ C$	
Switching characteristics	Rise time	t_r		-	-	0.15	μs	only Q1
	Fall time	t_f		-	-	0.35	μs	19-8 terminal
Thermal resistance	Channel to case	$R_{th(ch-c)}$	Only Q1 or Q2 heating	-	-	3.5	$^\circ C/W$	Q1 and Q2
	Channel to ambient	$R_{th(ch-a)}$	Q1 and Q2 heating	-	-	84	$^\circ C/W$	

Note:

Capacitor of 2000pF or more should be connected between CON and GND terminals.

Fuji Electric Device Technology Co., Ltd.

DWG. NO.

MS5F06456 7/24

8.Characteristics Diagram : $V_{CC}=19V, T_c=T_j(IC)=T_{ch}(Q1, Q2)=25^{\circ}C, F=75kHz$

[MOS-FET]

Allowable Power Dissipation

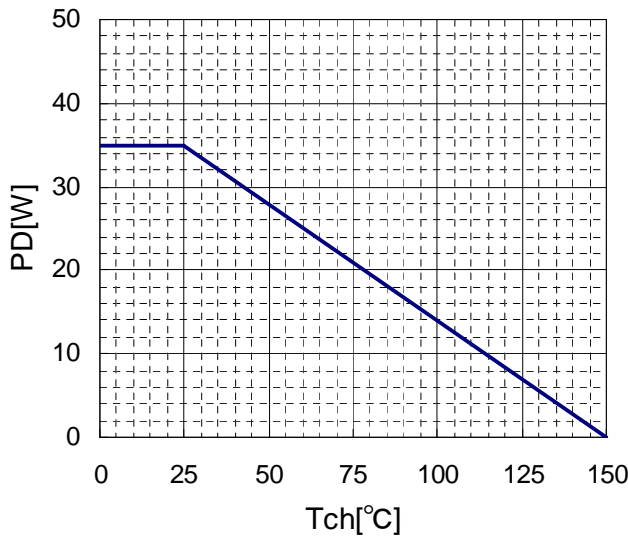

Safe operating area

$T_c=25^{\circ}C, D=0.01$

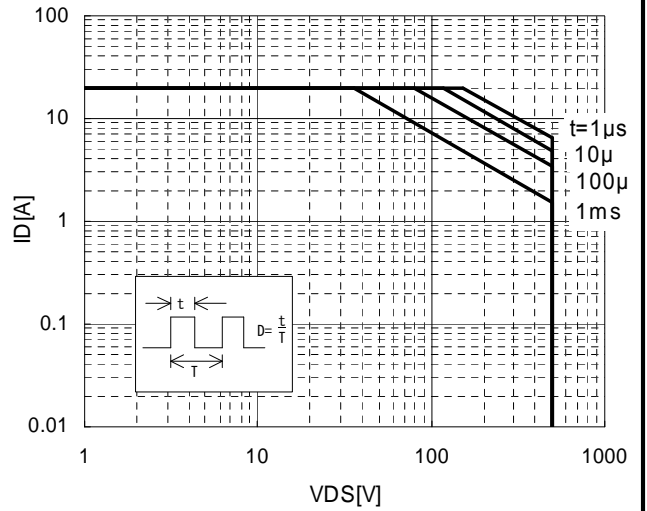

Output Characteristics

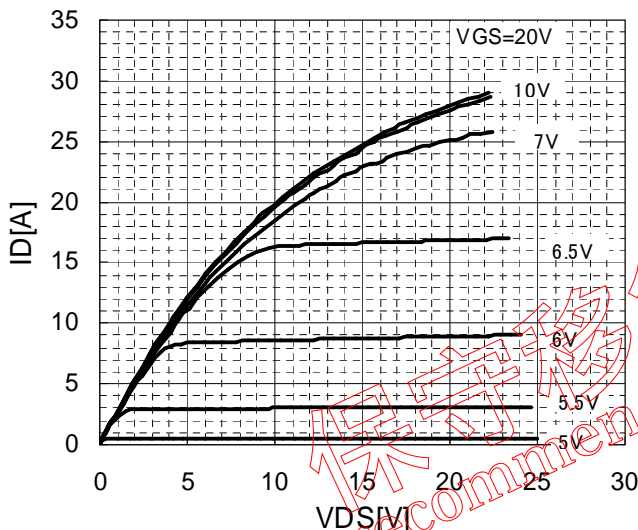

Transfer Characteristics

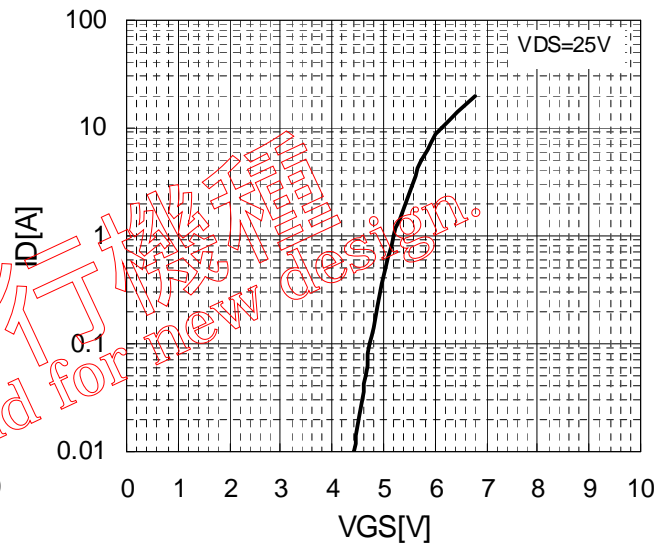

Transconductance

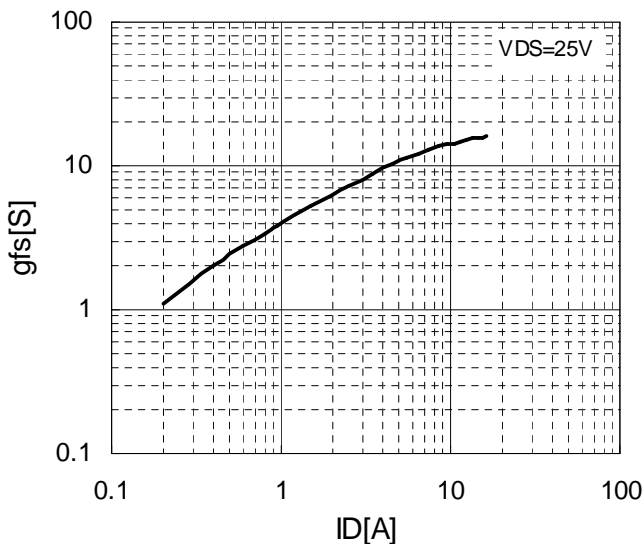

Drain-Source on-state Resistance

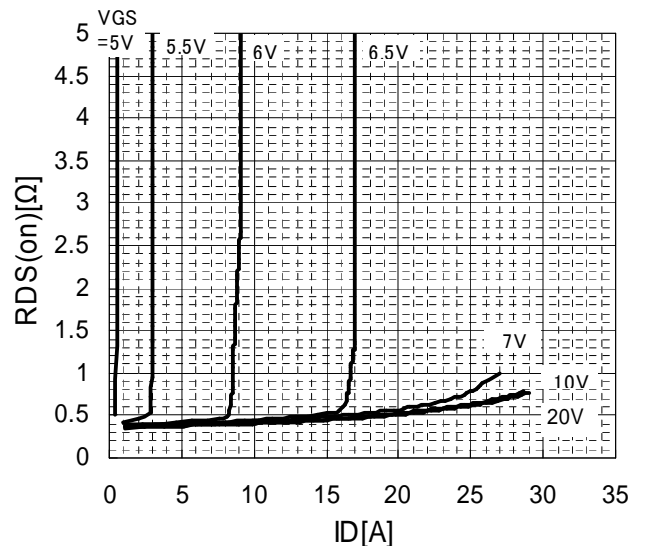

This material and the information herein is the property of Fuji Electric Device Technology Co.,Ltd. They shall be neither reproduced, copied, lent, or disclosed in any way whatsoever for the use of any third party nor used for the manufacturing purposes without the express written consent of Fuji Electric Device Technology Co.,Ltd.

富士電機株式会社
Not recommend for new design.

This material and the information herein is the property of Fuji Electric Device Technology Co.,Ltd. They shall be neither reproduced, copied, lent, or disclosed in any way whatsoever for the use of any third party nor used for the manufacturing purposes without the express written consent of Fuji Electric Device Technology Co.,Ltd.

Drain-Source on-state Resistance

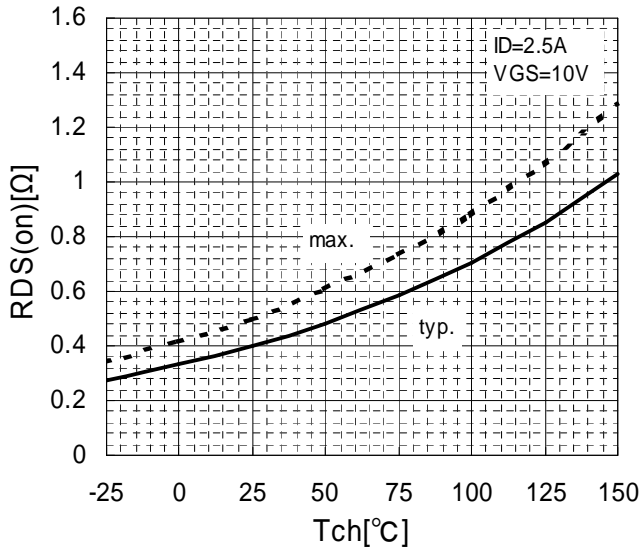

Gate Threshold Voltage vs Tch

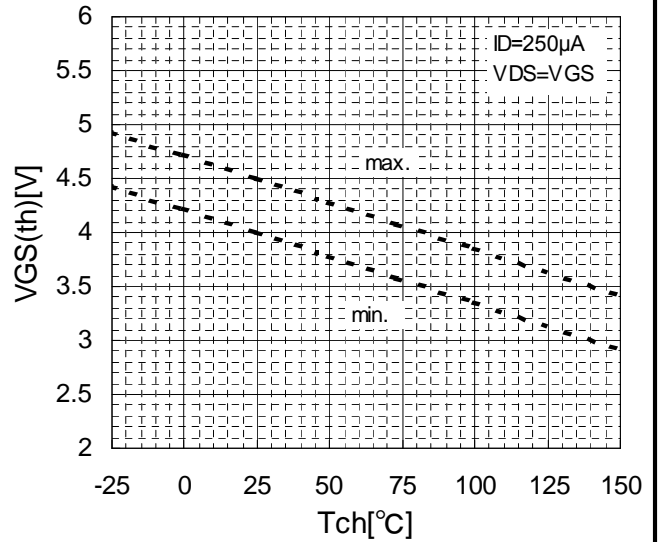

Gate Charge Characteristics

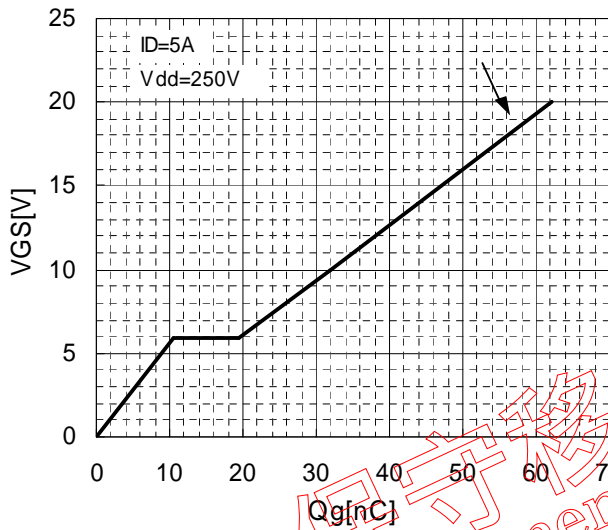

Capacitance

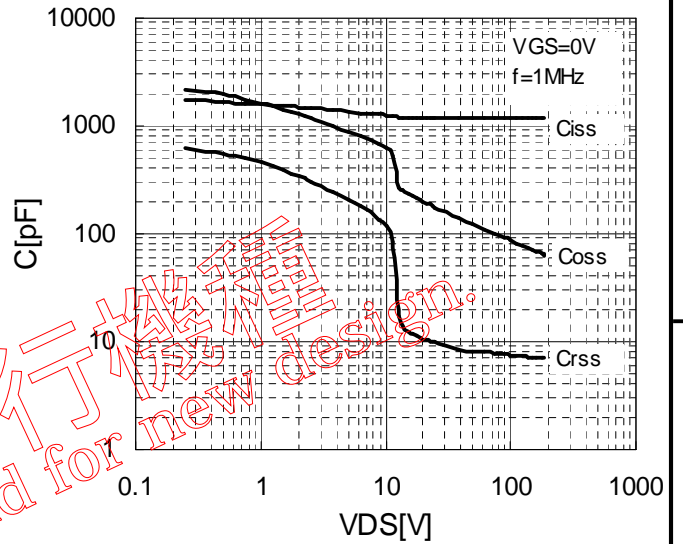

Forward Characteristics of Reverse Diode

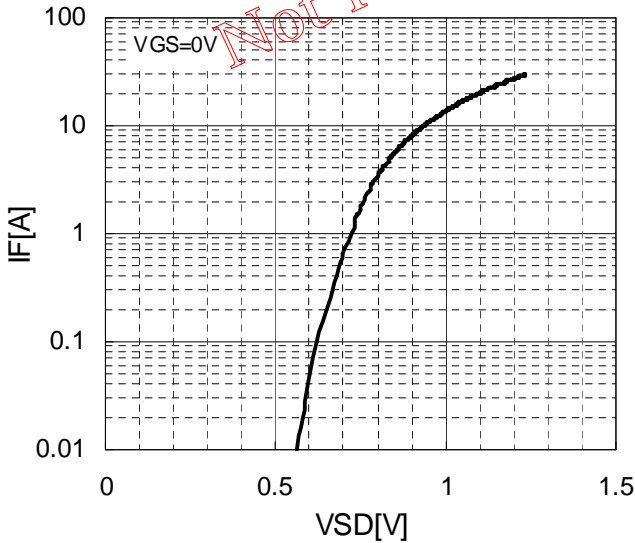

Transient Thermal Impedance

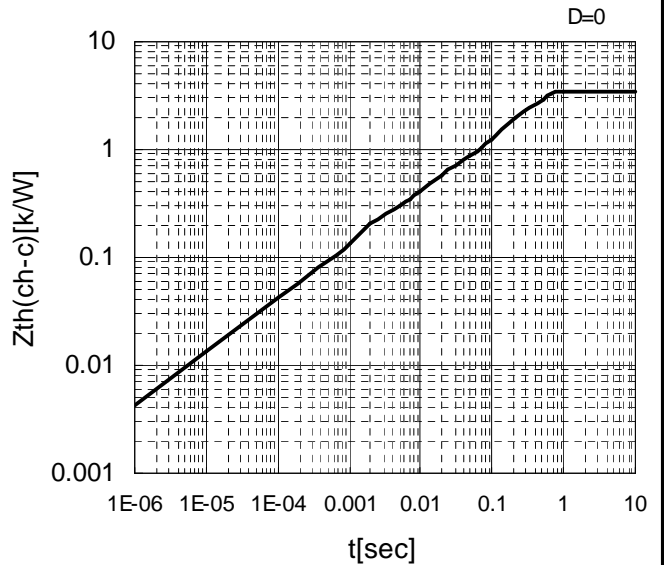

This material and the information herein is the property of Fuji Electric Device Technology Co.,Ltd. They shall be neither reproduced, copied,lent, or disclosed in any way whatsoever for the use of any third party nor used for the manufacturing purposes without the express written consent of Fuji Electric Device Technology Co.,Ltd.

[IC]

Vcc-icc : normal operation

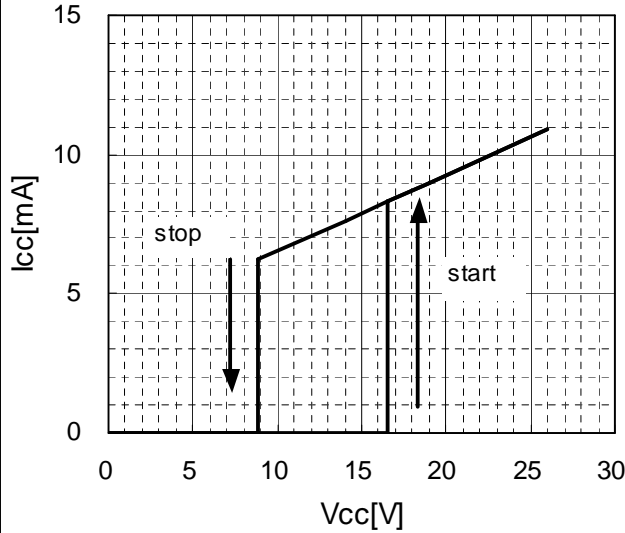

Vcc-icc : normal operation

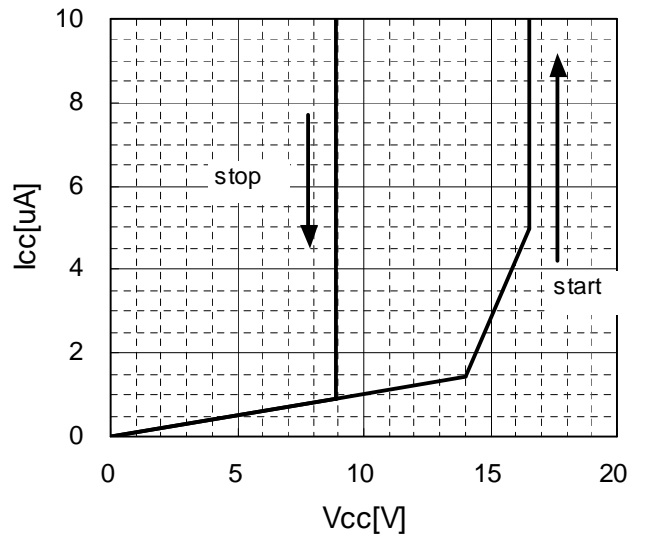

Vcc-icc : normal operation
latched shutdown

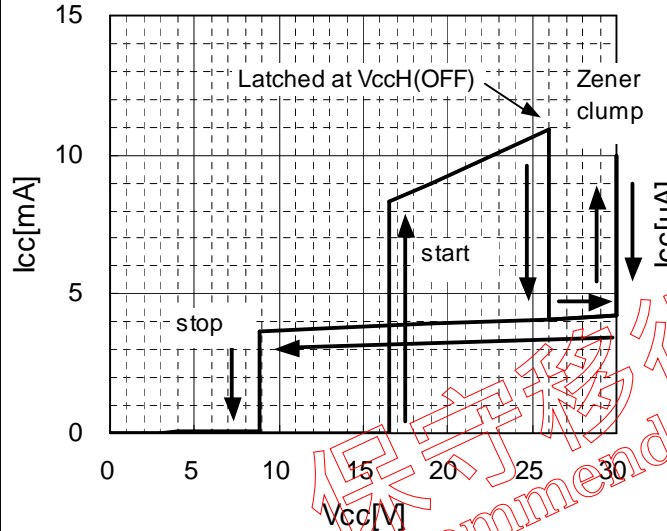

Vcc-icc : normal operation
latched shutdown

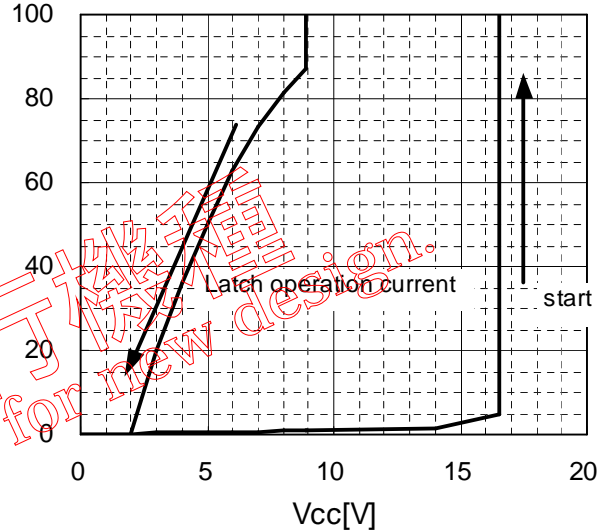

Vcc-icc : standby operation

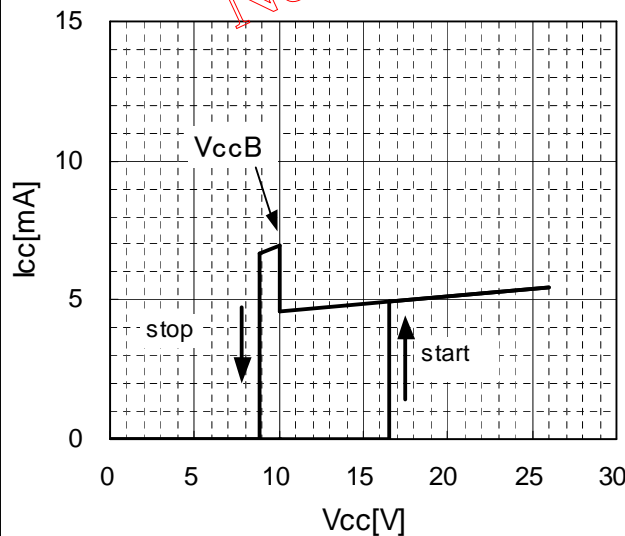

Vcc-icc : standby operation

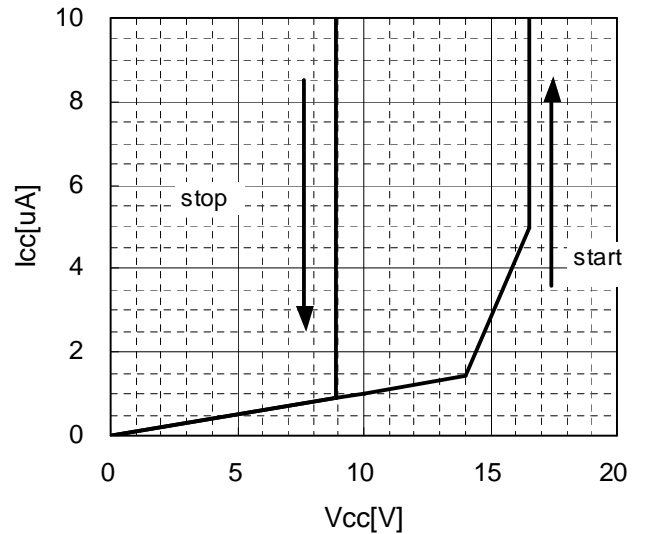

This material and the information herein is the property of Fuji Electric Device Technology Co.,Ltd. They shall be neither reproduced, copied, lent, or disclosed in any way whatsoever for the use of any third party nor used for the manufacturing purposes without the express written consent of Fuji Electric Device Technology Co.,Ltd.

Vcc-Icc : standby operation
latched shutdown

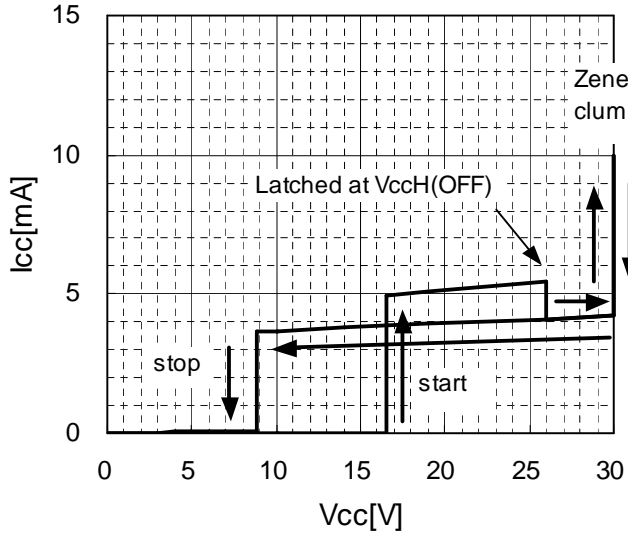

Vcc-Icc : standby operation
latched shutdown

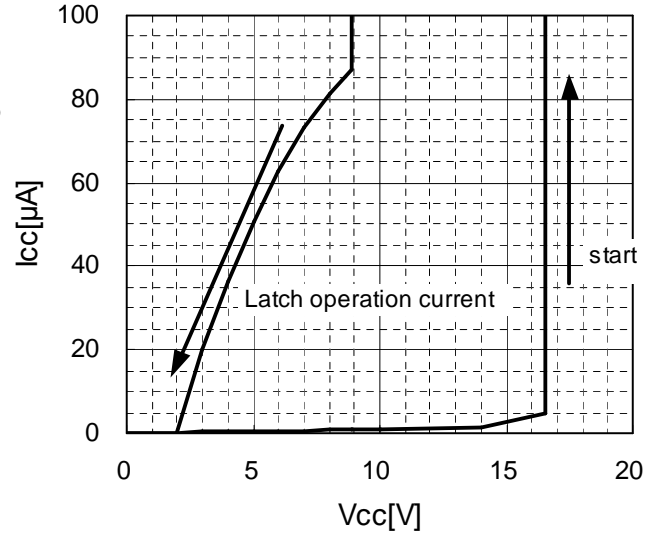

F-Icc

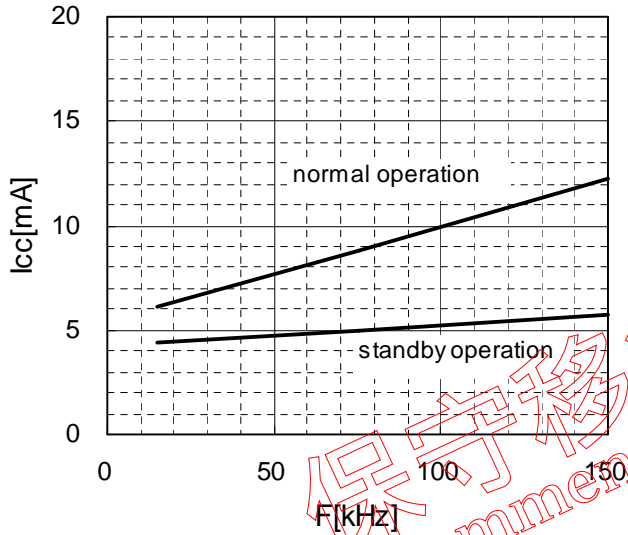

Burst duty-Icc

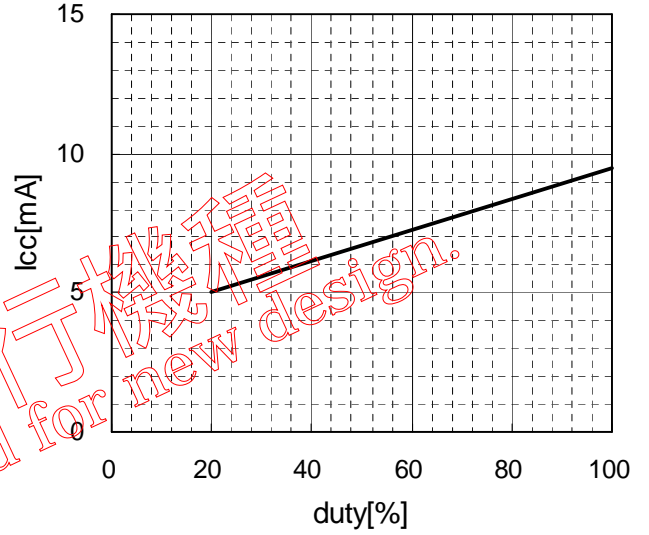

Tc=Tj=Tch-Icc

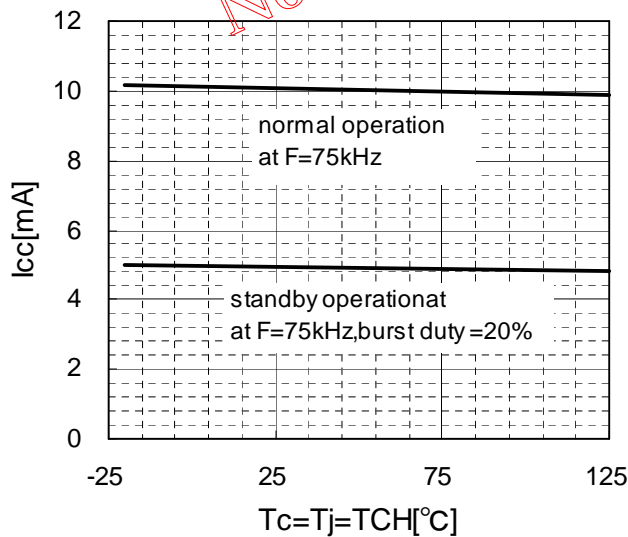

Tj=Tc=Tch-Vcc

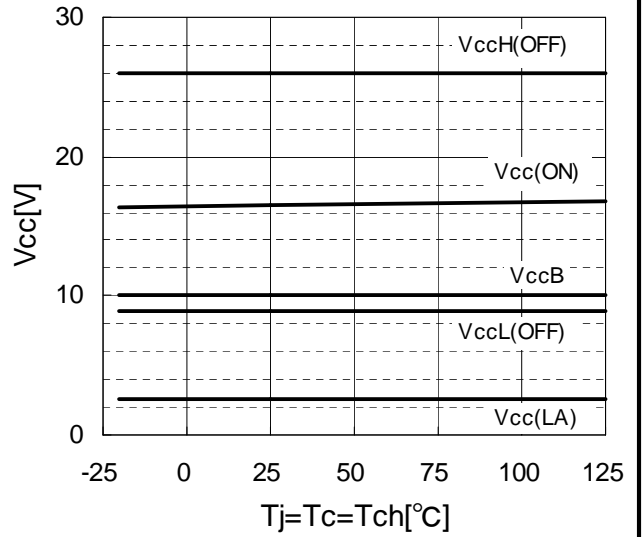

This material and the information herein is the property of Fuji Electric Device Technology Co.,Ltd. They shall be neither reproduced, copied, lent, or disclosed in any way whatsoever for the use of any third party nor used for the manufacturing purposes without the express written consent of Fuji Electric Device Technology Co.,Ltd.

Allowable Power Dissipation

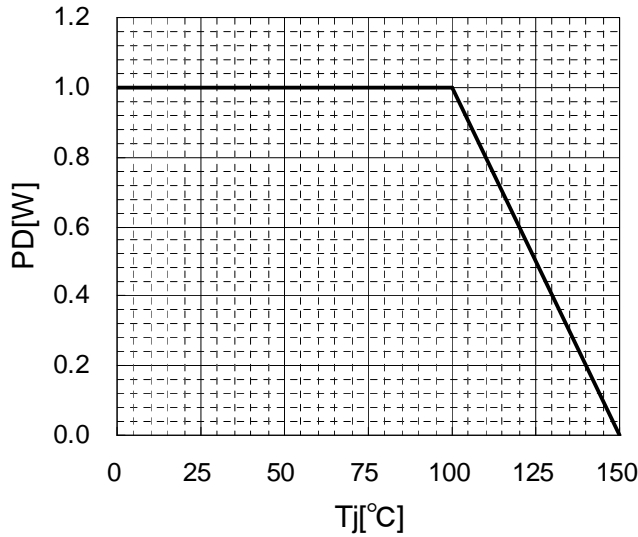

Allowable frequency at standby operation

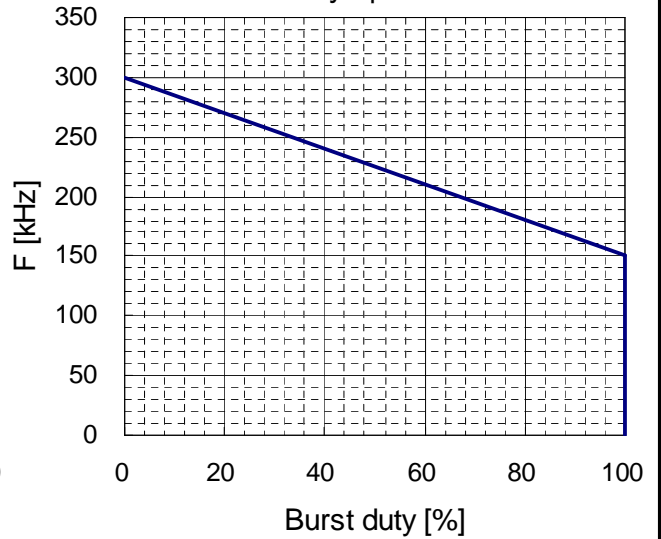

Vcc-VREF

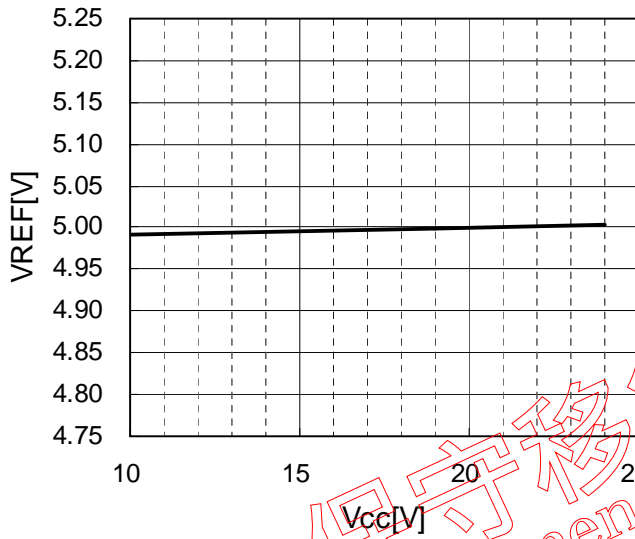

Tc=Tj=TCH-VREF

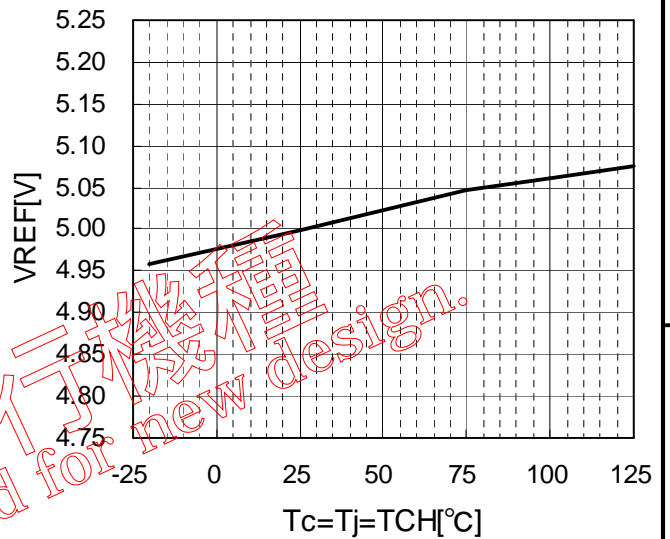

CON-tON

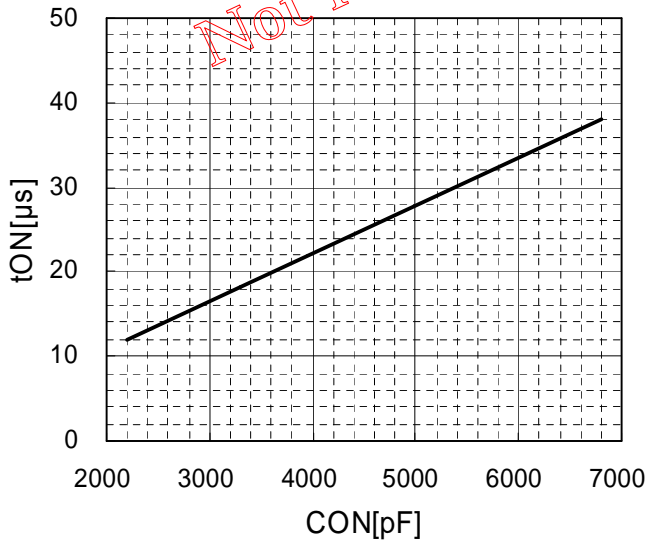

Tc=Tj=TCH-tON

at CON=3300pF

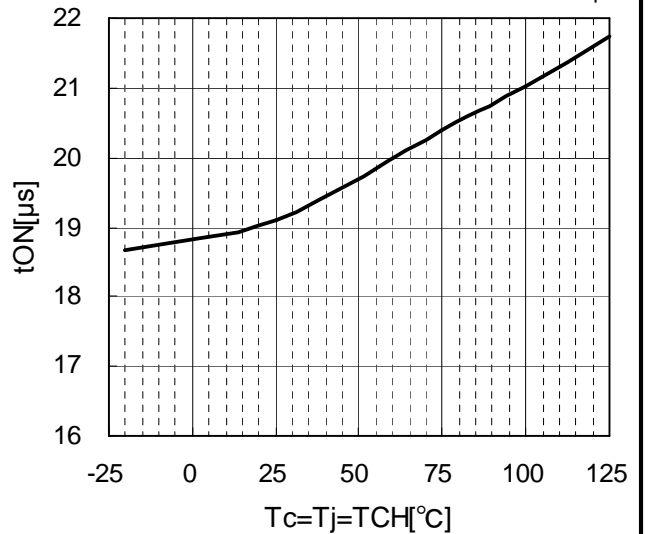

This material and the information herein is the property of Fuji Electric Device Technology Co.,Ltd. They shall be neither reproduced, copied, lent, or disclosed in any way whatsoever for the use of any third party nor used for the manufacturing purposes without the express written consent of Fuji Electric Device Technology Co.,Ltd.

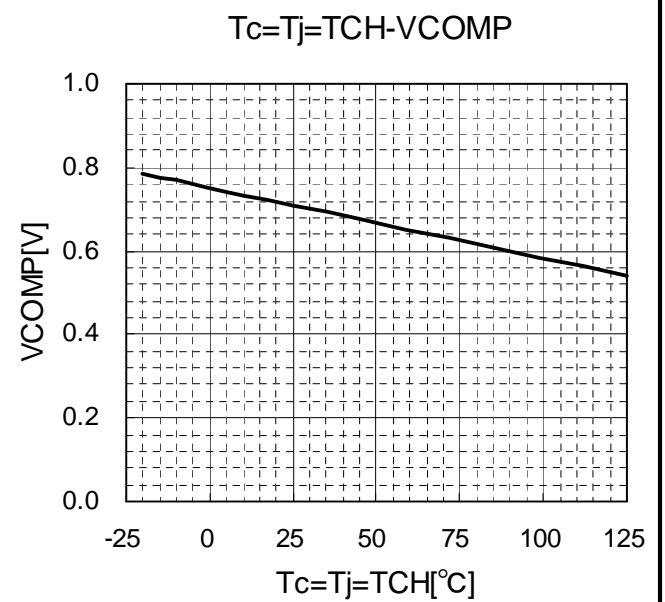
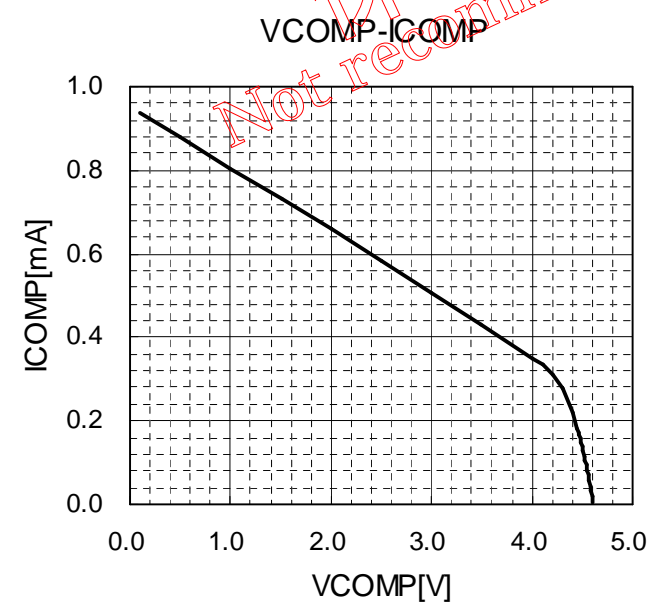
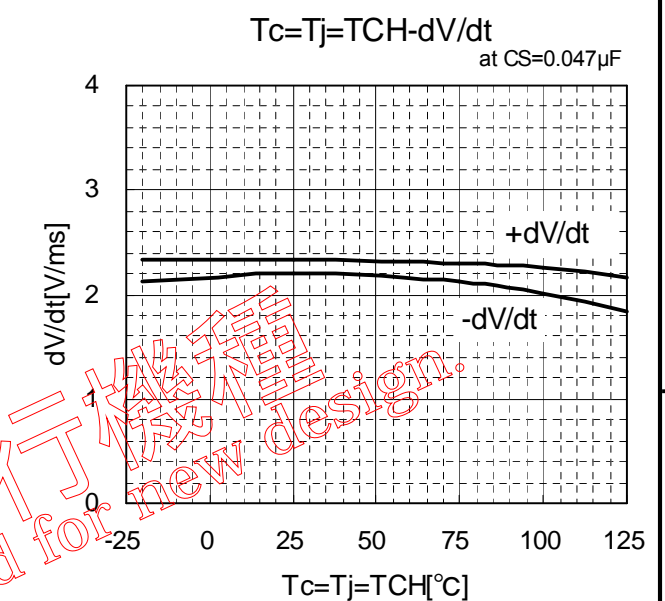
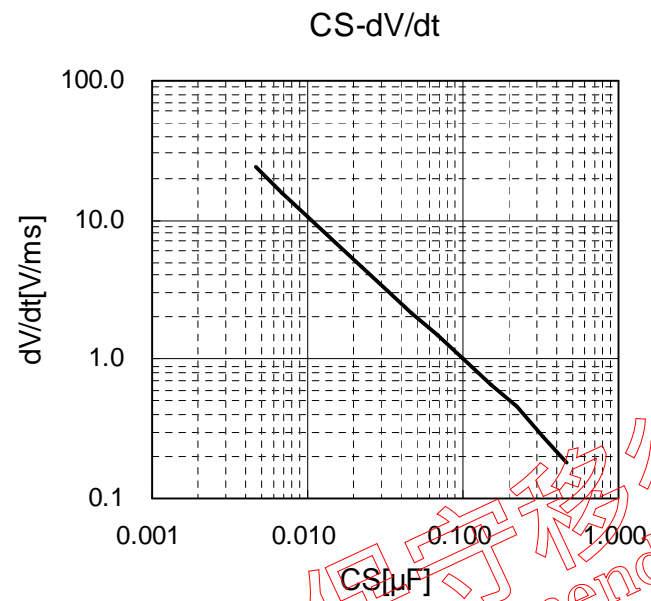
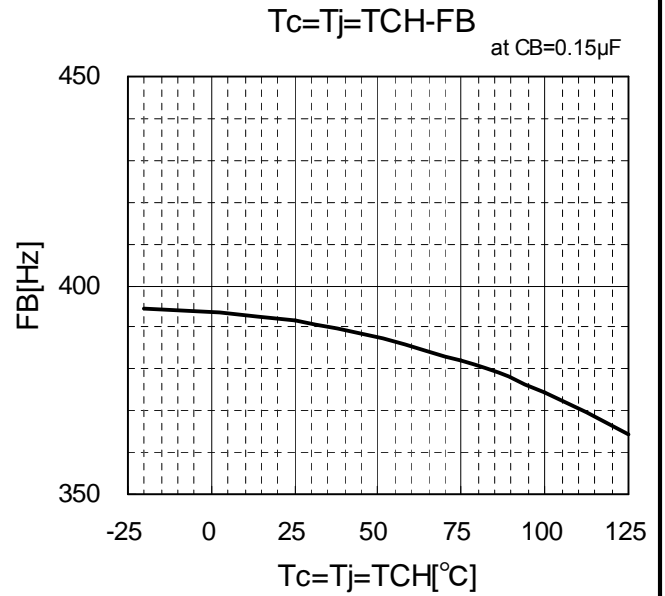
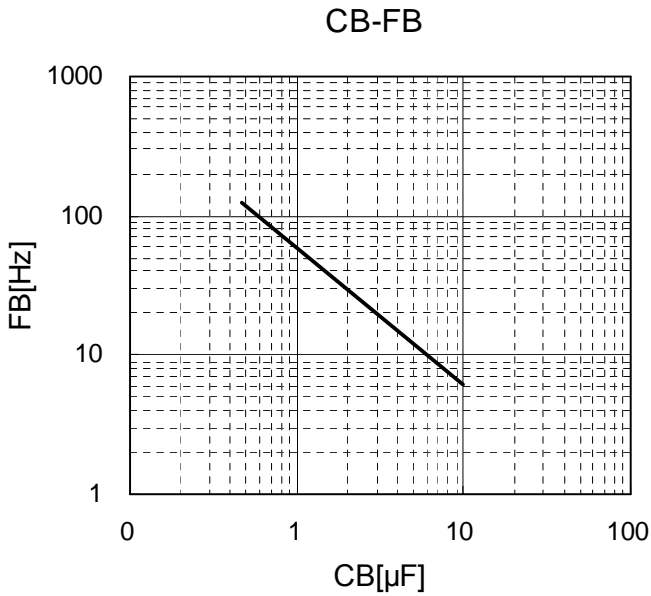

This material and the information herein is the property of Fuji Electric Device Technology Co., Ltd. They shall be neither reproduced, copied, lent, or disclosed in any way whatsoever for the use of any third party nor used for the manufacturing purposes without the express written consent of Fuji Electric Device Technology Co., Ltd.

VCS-VCON

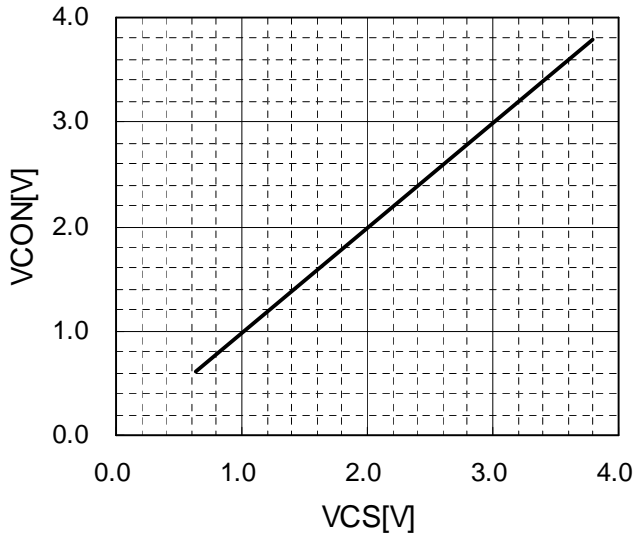

VCOMP-VCON

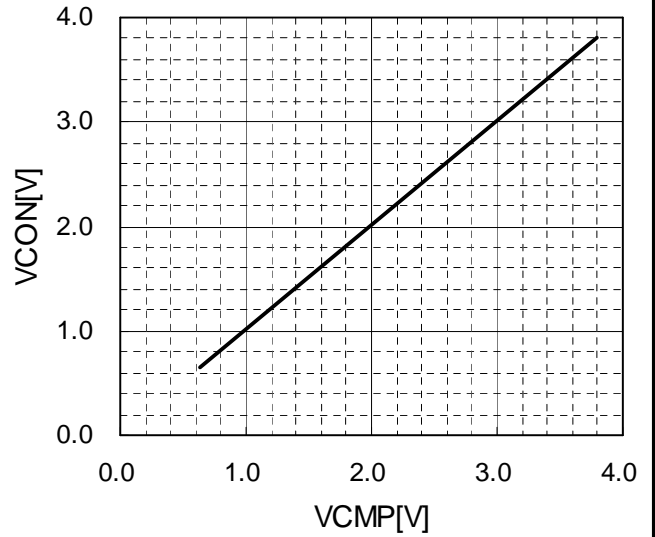

Tc=Tj=TCH-VSTB

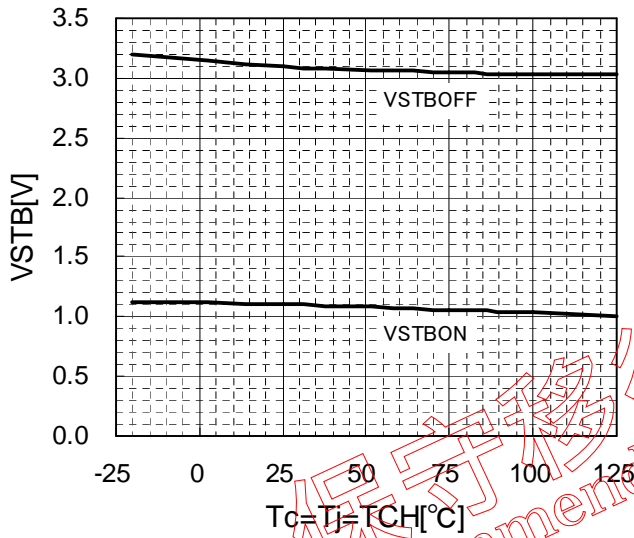

Tc=Tj=TCH-RSTB

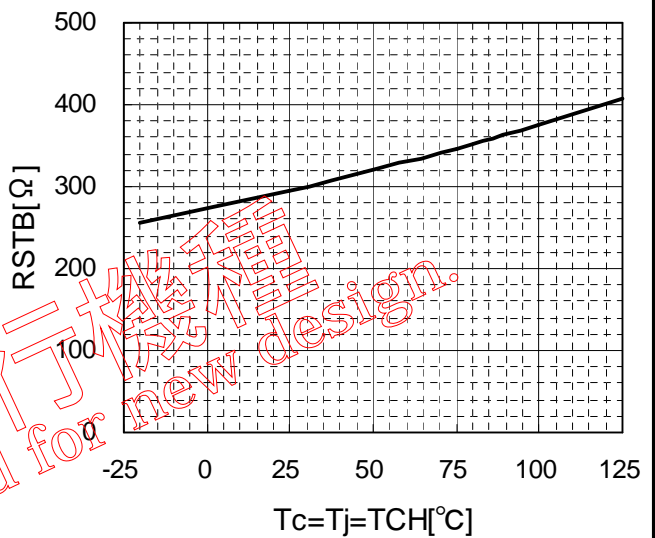

Tc=Tj=TCH-VW

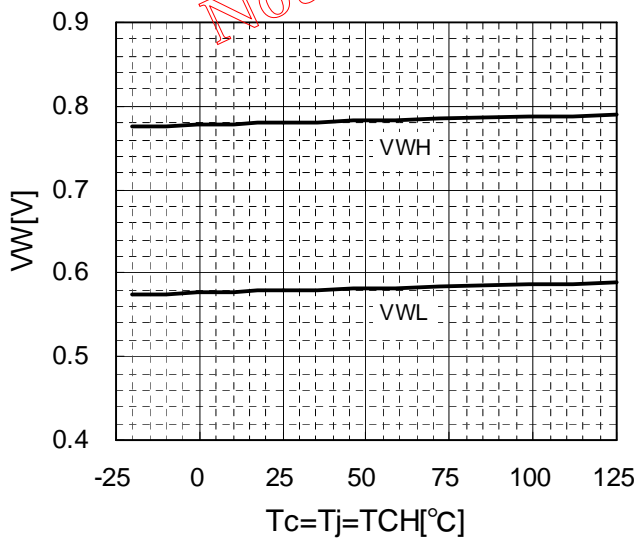

Tc=Tj=TCH-VOC, VSC

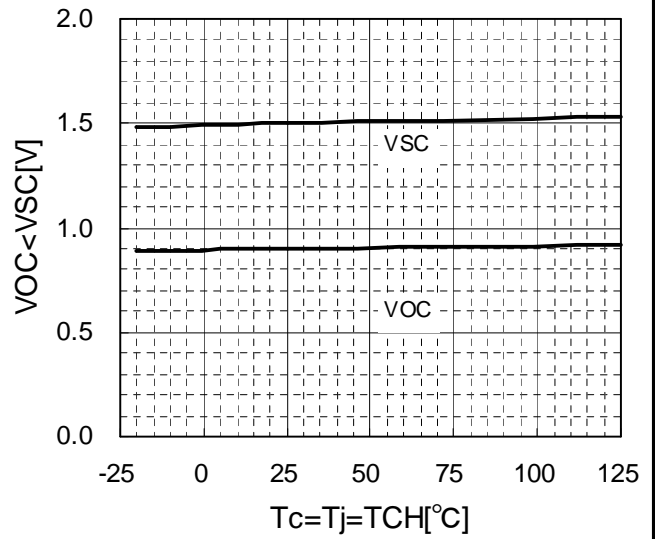

This material and the information herein is the property of Fuji Electric Device Technology Co.,Ltd. They shall be neither reproduced, copied, lent, or disclosed in any way whatsoever for the use of any third party nor used for the manufacturing purposes without the express written consent of Fuji Electric Device Technology Co.,Ltd.

$T_c=T_j=T_{CH}-tdLA$

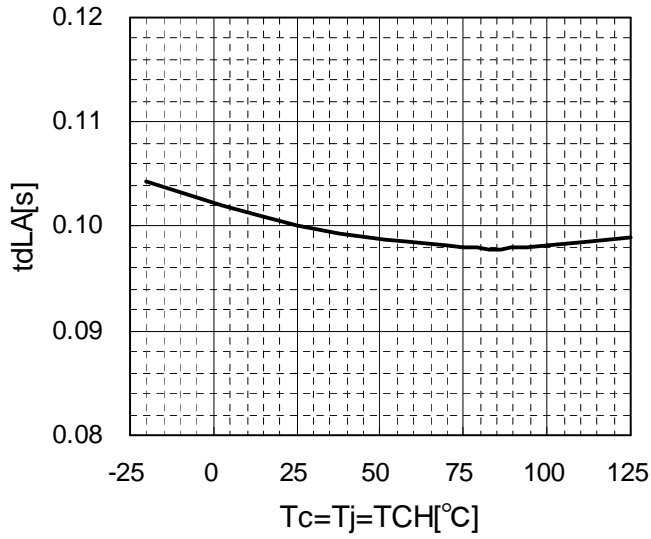

$T_c=T_j=T_{CH}-tr1,tf1(Q1)$

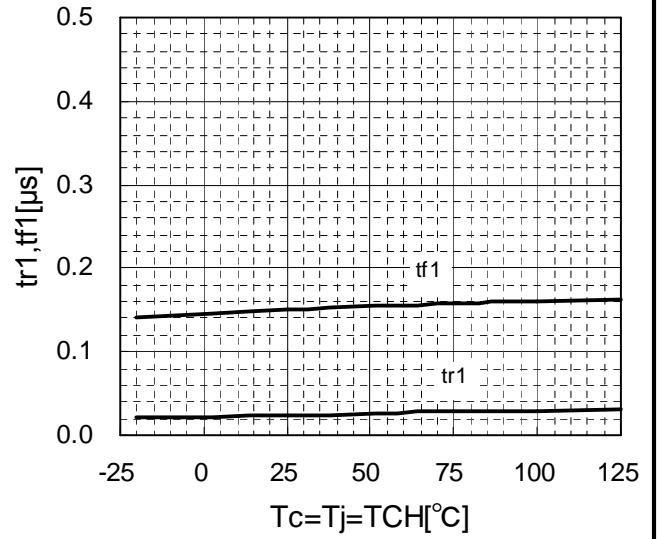

保守移行機種
Not recommend for new design.

9. Description

Item	Test circuit	description
V_{DSS}	Fig.1	$V_{CC}=V_{GS}=0V, I_D=250\mu A$
$V_{GS(th)}(Q2)$	Fig.2	$I_D=250\mu A, V_{GS}=V_{DS}$
I_{DSS}	Fig.3	$V_{CC}=V_{GS}=0V, V_{DS}=500V$
$R_{DS(ON)}(Q1)$	Fig.4	$V_{CC}=V_{GS}=19V, I_D=2.5A$
$R_{DS(ON)}(Q2)$	Fig.5	$V_{GS}=10V, I_D=2.5A$
V_{SD}	Fig.6	$I_F=10A, V_{CC}=V_{GS}=0V$
$V_{CC(ON)}$	Fig.7	Vcc voltage to output VREF after Vcc's going up from 0V.
$V_{CCL(OFF)}$	Fig.7	Vcc voltage to stop outputting VREF after Vcc's going down from $V_{CC(ON)}$.
V_{CCH}	-	$=V_{CC(ON)} - V_{CCL(OFF)}$
V_{CCB}	Fig.8	Vcc voltage to cancel standby operation after Vcc's going down at standby operation(STB=L).
V_{CCBH}	-	$=V_{CCB} - V_{CCL(OFF)}$
$V_{CCH(OFF)}$	Fig.8	Vcc voltage to latching shutdown after Vcc's going up from $V_{CC(ON)}$.
$V_{CC(LA)}$	Fig.8	Vcc voltage to cancel latching shutdown operation.
I_{CC}	Fig.8	$V_{CC}=19V$, Vcc terminal current at 75kHz operation.
V_Z	Fig.7	Vcc voltage at $I_{CC}=10mA$.
V_{REF}	Fig.7	Reference output voltage.
$I_{ON(DIS)}$	Fig.8	Sink current at CON terminal.
$I_{ON(CHG)}$	Fig.8	Source current at CON terminal.
V_{ONLH}	Fig.8	The amplitude voltage at CON terminal.
$V_{ON(MAX)}$	Fig.8	Threshold voltage at H level of V_{ONLH} .
$I_{B(DIS)}$	Fig.8	Sink current at CB terminal.
$I_{B(CHG)}$	Fig.8	Source current at CB terminal.
V_{BLH}	Fig.8	The amplitude voltage at CB terminal.
$I_{S(DIS)}$	Fig.8	Sink current at CS terminal.
$I_{S(CHG)}$	Fig.8	Source current at CS terminal.
V_{B2H}	Fig.8	Start threshold voltage of Q1 switching.
V_{B2L}	Fig.8	Stop threshold voltage of Q1 switching.
V_{COMP}	Fig.8	Stop threshold voltage of Q1 switching.
I_{COMP}	Fig.8	Source current at COMP terminal.
V_{STBON}	Fig.9	Standby threshold voltage after V_{STB} 's going down from V_{STBOFF} .
V_{STBOFF}	Fig.9	Standby cancellation voltage after V_{STB} 's going up from V_{STBON} .
R_{STB}	Fig.10	Internal resistance at latched-shutdown.
V_{WH}	Fig.11	Q1 turn-on threshold voltage after Vw's going up.
V_{WL}	Fig.11	Q1 turn-off threshold voltage after Vw's going down.
V_{OC}	Fig.12	S1 terminal voltage of over current with latched shutdown.(0.1 second timer)
td_{LA}	Fig.12	In continuously abnormal state, time until latching shutdown.
td_{LAR}	Fig.12	In uncontinuously abnormal state, time to cancel latching shutdown timer.
V_{SC}	Fig.12	S1 terminal voltage of short circuit current with latched shutdown.(1 time)
t_r	Fig.8	Rise time of MOS-FET(Q1).
t_f	Fig.8	Fall time of MOS-FET(Q1).
t_{ON}	-	Maximum ON width of MOS-FET(Q1).
C_{ON}	-	The capacitance which is connected between CON and GND.
F_B	-	Burst frequency at standby operation.
C_B	-	The capacitance which is connected between CB and GND.
dV/dt	-	dV/dt of CS terminal voltage.
C_S	-	The capacitance which is connected between CS and GND.
T_C	-	Case temperature.(back side of package)
T_J	-	Junction temperature of control IC.
T_{CH}	-	Channel temperature of MOS-FET(Q1 and Q2).
F	-	Switching frequency of Q1.

This material and the information herein is the property of Fuji Electric Device Technology Co.,Ltd. They shall be neither reproduced, copied, lent, or disclosed in any way whatsoever for the use of any third party nor used for the manufacturing purposes without the express written consent of Fuji Electric Device Technology Co.,Ltd.

This material and the information herein is the property of Fuji Electric Device Technology Co.,Ltd. They shall be neither reproduced, copied, lent, or disclosed in any way whatsoever for the use of any third party nor used for the manufacturing purposes without the express written consent of Fuji Electric Device Technology Co.,Ltd.

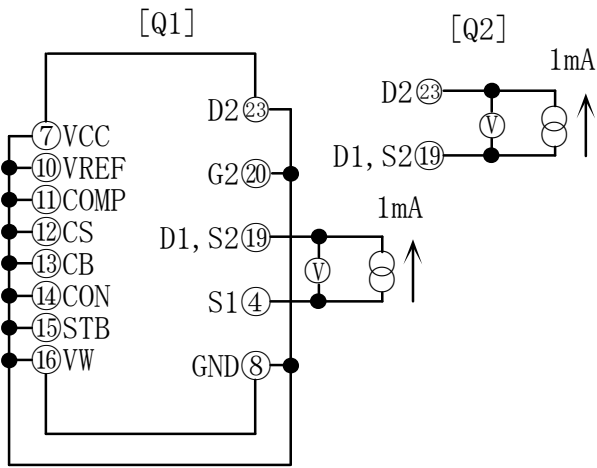

Fig.1 VDSS

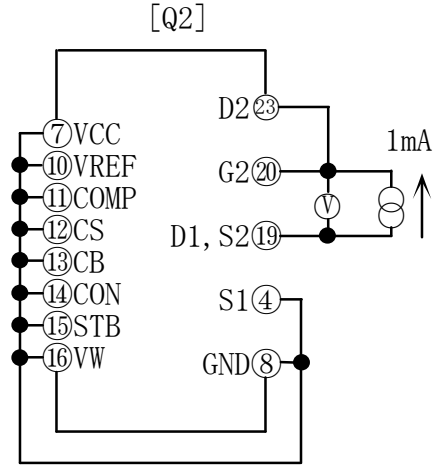

Fig.2 VGS(th)

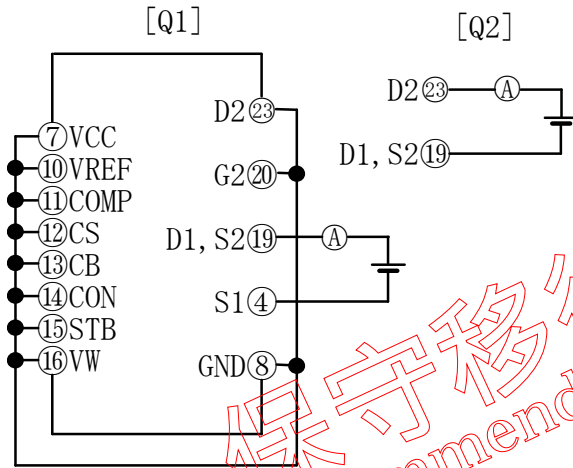

Fig.3 IDSS

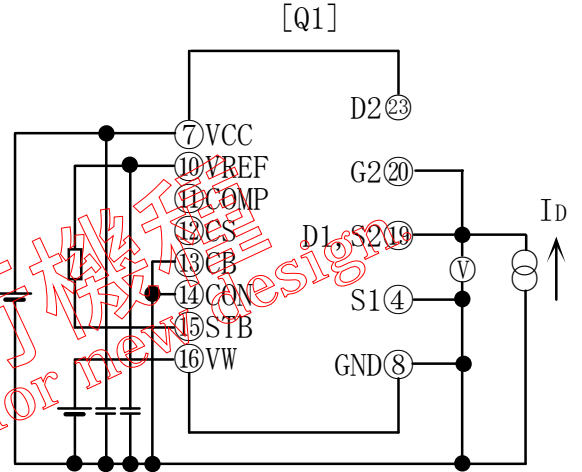

Fig.4 RDS(ON):Q1

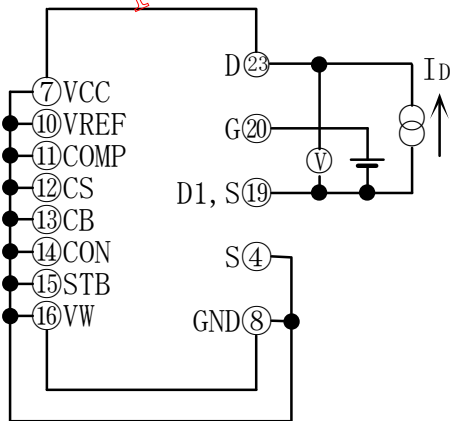

Fig.5 RDS(ON):Q2

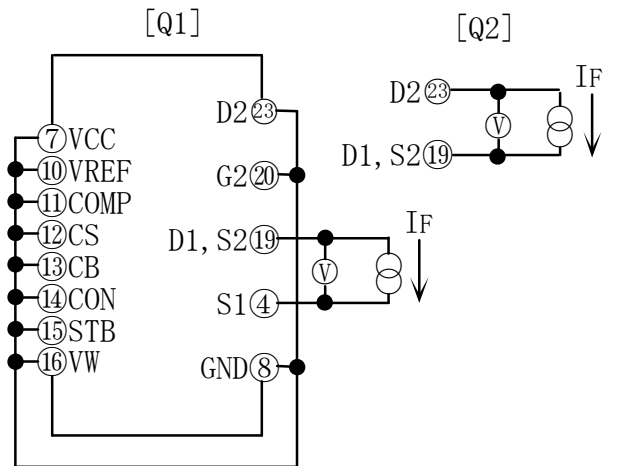

Fig.6 VSD

This material and the information herein is the property of Fuji Electric Device Technology Co.,Ltd. They shall be neither reproduced, copied, lent, or disclosed in any way whatsoever for the use of any third party nor used for the manufacturing purposes without the express written consent of Fuji Electric Device Technology Co.,Ltd.



図 7 . VCC(ON), 他
 Fig.7 VCC(ON),etc...



図 8 . VCCB, 他
 Fig.8 VCCB,etc...

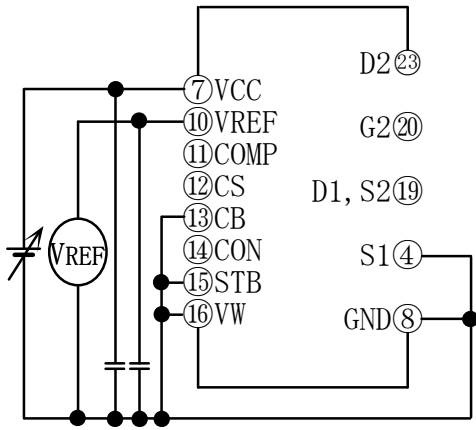

図 9 . VSTB
 Fig.9 VSTB

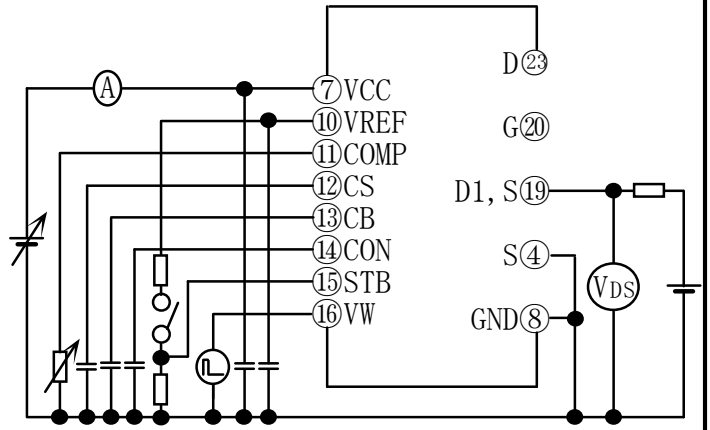

図 10 . RSTB
 Fig.10 RSTB

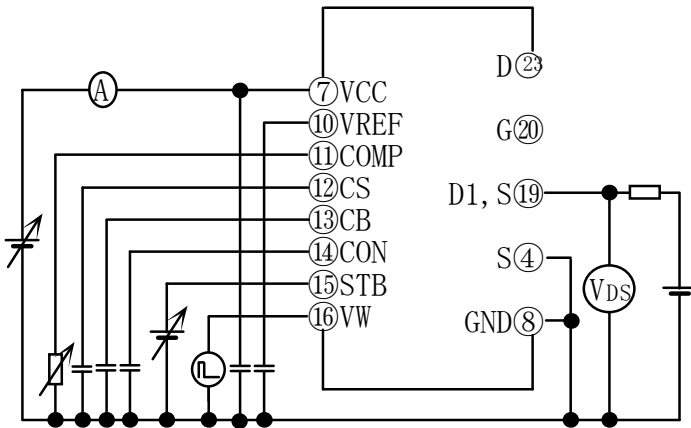

図 1 1 . VW
 Fig.11 VW

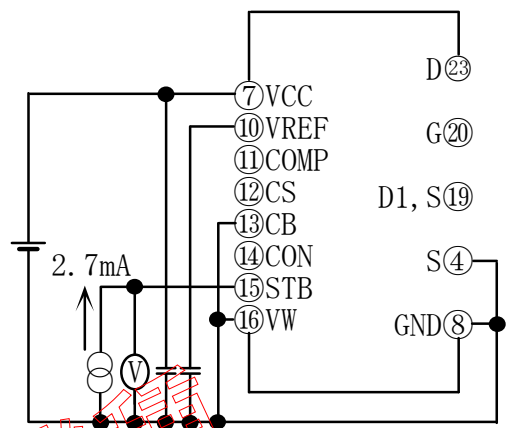

図 1 2 . Voc, 他
 Fig.12 VOC,etc...

10. Reliability test items

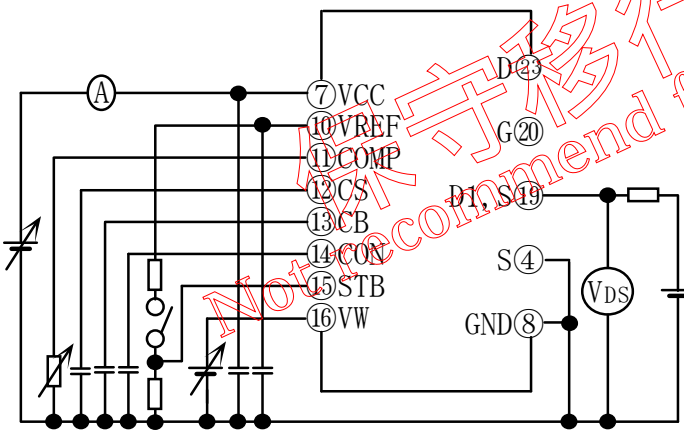
All guaranteed values are under the categories of reliability per non-assembled.

	Test No.	Test Items	Testing methods and Conditions	Reference Standard EIAJ ED4701	Sampling number	Acceptance number
Mechanical test methods	1	Terminal Strength (Tensile)	Pull force : 10N Force maintaining duration :10±1sec	A-111A method 1	5	(0:1)
	2	Terminal Strength (Bending)	Load force : 5N Number of times :2times(90deg./time)	A-111A method 3	5	
	3	Mounting Strength	Pressure-bonding force : 80N	A-112 method 3	5	
	4	Vibration	frequency : 100Hz to 2kHz Acceleration : 200m/s ² Sweeping time : 4min./1 cycle 4cycles for each X,Y&Z directions.	A-121A	15	
	5	Shock	Peak amplitude: 15km/s ² Duration time : 0.5ms 3times for each X,Y&Z directions.	A-122A test code D	15	
	6	Solderability	Solder temp. : 245±5°C Immersion time : 5±0.5sec Each terminal shall be immersed in the solder bath within 1 to 1.5mm from the body.	A-131A test code A	15	
	7	Resistance to Soldering Heat	Solder temp. : 260±5°C Immersion time : 10±1sec Number of times : 1time	A-132	15	
Climatic test methods	1	High Temp. Storage	Temperature : 150+5/-5°C Test duration : 1000hr	B-111A	22	(0:1)
	2	Low Temp. Storage	Temperature : -40+5/-5°C Test duration : 1000hr	B-112A	22	
	3	Temperature Humidity Storage	Temperature : 85±2°C Relative humidity : 85±5% Test duration : 1000hr	B-121A test code C	22	
	4	Temperature Humidity BIAS	Temperature : 85±2°C Relative humidity : 85±5% Bias Voltage : $V_{DS}(\max) * 0.8, V_{CC}=24V,$ $V_{COMP}=0V$ Test duration : 1000hr	B-122A test code C	22	
	5	Unsaturated Pressurized Vapor	Temperature : 130±2°C Relative humidity : 85±5% Vapor pressure : 230kPa Test duration : 96hr	B-123A test code C	22	
	6	Temperature Cycle	High temp.side : 150±5°C Low temp.side : -40±5°C Duration time : HT 30min,LT 30min Number of cycles : 100cycles	B-131A test code A	22	
	7	Thermal Shock	Fluid : pure water(running water) High temp.side : 100+0/-5°C Low temp.side : 0+5/-0°C Duration time : HT 5min,LT 5min Number of cycles : 10cycles	B-141A test code A	22	

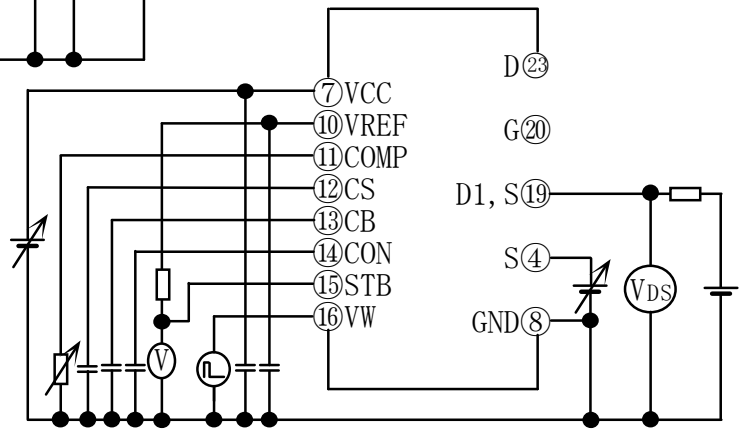
	Test No.	Test Items	Testing methods and Conditions	Reference Standard EIAJ ED4701	Sampling number	Acceptance number
Endurance test methods	1	Intermittent Operating Life	$T_a=25\pm 5^{\circ}\text{C}$ $\Delta T_c=90\text{degree}$ $T_{ch}\leq T_{ch}(\text{max.})$ Test duration : 3000 cycle	D-322	22	(0:1)
	2	HTRB (Drain-Source)	Temperature : $150+0/-15^{\circ}\text{C}$ Bias Voltage : $V_{DS}=V_{DS}(\text{max})\cdot 0.8,$ $V_{CC}=V_{CC}(\text{max}), V_{COMP}=0\text{V}$ Test duration : 1000hr	D-323	22	

Failure Criteria

Item	Symbol	Failure Criteria		Unit	
		Lower Limit	Upper Limit		
Electrical Characteristics	Drain-source breakdown voltage	BV_{DSS}	$L\times 0.8$	-	V
	Zero gate voltage drain current	I_{DSS}	-	$U\times 2$	A
	Drain-source on-state resistance	$R_{DS(ON)}$	-	$U\times 1.2$	Ω
	Diode forward on-voltage	V_{SD}	-	$U\times 1.2$	V
	Start threshold voltage	$V_{CC(ON)}$	$L\times 0.9$	$U\times 1.1$	V
	Stop threshold voltage	$V_{CCL(OFF)}$	$L\times 0.9$	$U\times 1.1$	V
	Hysteresis	V_{CCH}	$L\times 0.9$	$U\times 1.1$	V
	Cancellation voltage of burst operation	V_{CCB}	$L\times 0.9$	$U\times 1.1$	V
	Hysteresis	V_{CCBH}	$L\times 0.9$	$U\times 1.1$	V
	Over voltage threshold voltage	$V_{CCH(OFF)}$	$L\times 0.9$	$U\times 1.1$	V
	Operating current	I_{ec}	$L\times 0.8$	$U\times 1.2$	mA
	Reference voltage	V_{REF}	$L\times 0.9$	$U\times 1.1$	V
	Charge current	$I_{ON(CHG)}$	$L\times 0.8$	$U\times 1.2$	mA
	Charge current	$I_{B(CHG)}$	$L\times 0.8$	$U\times 1.2$	mA
	Charge current	$I_{S(CHG)}$	$L\times 0.8$	$U\times 1.2$	mA
	Over current operating voltage	V_{oc}	$L\times 0.9$	$U\times 1.1$	V
	Stop voltage	V_{comp}	$L\times 0.9$	$U\times 1.1$	V
	Standby threshold voltage	V_{STBON}	$L\times 0.9$	$U\times 1.1$	V
Q1 turn-on threshold voltage	V_{WH}	$L\times 0.9$	$U\times 1.1$	V	

* LSL : Lower Specification Limit

* USL : Upper Specification Limit

* Before any of electrical characteristics measure, all testing related to the humidity have conducted after drying the package surface for more than an hour at 150°C .

11. Cautions

- Although Fuji Electric is continually improving product quality and reliability, a small percentage of semiconductor products may become faulty. When using Fuji Electric semiconductor products in your equipment, you are requested to take adequate safety measures to prevent the equipment from causing physical injury, fire, or other problem in case any of the products fail. It is recommended to make your design fail-safe, flame retardant, and free of malfunction.
- The products described in this Specification are intended for use in the following electronic and electrical equipment which has normal reliability requirements.
 - Computers · OA equipment · Communications equipment(Terminal devices)
 - Machine tools · AV equipment · Measurement equipment
 - Personal equipment · Industrial robots · Electrical home appliances etc.
- The products described in this Specification are not designed or manufactured to be used in equipment or systems used under life-threatening situations. If you are considering using these products in the equipment listed below, first check the system construction and required reliability, and take adequate safety measures such as a backup system to prevent the equipment from malfunctioning.
 - Backbone network equipment · Transportation equipment (automobiles, trains, ships, etc.)
 - Traffic-signal control equipment · Gas alarms, leakage gas auto breakers
 - Submarine repeater equipment · Burglar alarms, fire alarms, emergency equipment
 - Medical equipment · Nuclear control equipment etc.
- Do not use the products in this Specification for equipment requiring strict reliability such as (but not limited to):
 - Aerospace equipment · Aeronautical equipment

12. Warnings

- The MOSFETs should be used in products within their absolute maximum rating(voltage, current, temperature, etc.).
- The MOSFETs may be destroyed if used beyond the rating.
- We only guarantee the non-repetitive and repetitive Avalanche capability and not for the continuous Avalanche capability which can be assumed as abnormal condition .Please note the device may be destructed from the Avalanche over the specified maximum rating.
- The equipment containing MOSFETs should have adequate fuses or circuit breakers to prevent the equipment from causing secondary destruction (ex. fire, explosion etc. .).
- Use the MOSFETs within their reliability and lifetime under certain environments or conditions. The MOSFETs may fail before the target lifetime of your products if used under certain reliability conditions.
- Be careful when handling MOSFETs for ESD damage. (It is an important consideration.)
- When handling MOSFETs, hold them by the case (package) and don't touch the leads and terminals.
- It is recommended that any handling of MOSFETs is done on grounded electrically conductive floor and tablemats.

- Before touching a MOSFET terminal, Discharge any static electricity from your body and clothes by grounding out through a high impedance resistor (about 1MΩ)
- When soldering, in order to protect the MOSFETs from static electricity, ground the soldering iron or soldering bath through a low impedance resistor.
- You must design the MOSFETs to be operated within the specified maximum ratings(voltage, current, temperature, etc.) to prevent possible failure or destruction of devices.
- Consider the possible temperature rise not only for the channel and case, but also for the outer leads.
- Do not directly touch the leads or package of the MOSFETs while power is supplied or during operation in order to avoid electric shock and burns.
- The MOSFETs are made of incombustible material. However, if a MOSFET fails, it may emit smoke or flame. Also, operating the MOSFETs near any flammable place or material may cause the MOSFETs to emit smoke or flame in case the MOSFETs become even hotter during operation. Design the arrangement to prevent the spread of fire.
- The MOSFETs should not used in an environment in the presence of acid, organic matter, or corrosive gas(hydrogen sulfide, sulfurous acid gas etc.)
- The MOSFETs should not used in an irradiated environment since they are not radiation-proof.
- During open short test, the internal of the MOSFETs might explode instantaneously and the resin mold package might be blown off when high voltage is applied to the low voltage terminals. Make sure in your design that during open short test, high voltage will not be applied to the low voltage terminals. To avoid accidents and explosion damage if high voltage is applied, use fuses in your design.

Installation

- Soldering involves temperatures which exceed the device storage temperature rating. To avoid device damage and to ensure reliability, observe the following guidelines from the quality assurance standard.

Soldering methods

Solder temperature and duration

Package type	Methods	Soldering Temp. & Time	Note
Through hole package	A Solder dipping Soldering iron	260±5°C, 10±1sec	
	B Solder dipping Soldering iron	350±10°C, 3.5±0.5sec	

- The immersion depth of the lead should basically be up to the lead stopper and the distance should be a maximum of 1.5mm from the device.
- When flow-soldering, be careful to avoid immersing the package in the solder bath.
- Refer to the following the pressure-bonding force reference when mounting the device on a heat sink. Excess pressure-bonding force causes damage to the device and weak pressure-bonding force will increase the thermal resistance, both of which conditions may destroy the device.

Table 1: Recommended pressure-bonding force

Package style	Recommended pressure-bonding force	Note
SIP23	30 –80 N	

- The heat sink should have a flatness within $\pm 30\mu\text{m}$ and roughness within $10\mu\text{m}$. Also, keep the tightening torque within the limits of this specification.
- Improper handling may cause isolation breakdown leading to a critical accident.
ex.) Over plane off the edges of screw hole. (Recommended plane off the edge is $C < 1.0\text{mm}$)
- We recommend the use of thermal compound to optimize the efficiency of heat radiation. It is important to evenly apply the compound and to eliminate any air voids.
- We do not recommend to re-use the device once after solder is removed and detached from the board. The detached device may not withstand the thermal when solder is removed, or damage by mechanical force.

Storage

- The MOSFETs must be stored at a standard temperature of 5 to 35°C and relative humidity of 45 to 75%.
- If the storage area is very dry, a humidifier may be required. In such a case, use only deionized water or boiled water, since the chlorine in tap water may corrode the leads.
- The MOSFETs should not be subjected to rapid changes in temperature to avoid condensation on the surface of the MOSFETs. Therefore store the MOSFETs in a place where the temperature is steady.
- The MOSFETs should not be stored on top of each other, since this may cause excessive external force on the case.
- The MOSFETs should be stored with the lead terminals remaining unprocessed. Rust may cause presoldered connections to fail during later processing.
- The MOSFETs should be stored in antistatic containers or shipping bags.
- Under the above storage condition, use the MOSFETs within one year.

13. Compliance with pertaining to restricted substances

13-1) Compliance with the RoHS Regulations and Exemptions

This product will be fully compliant with the RoHS directive.
Five out of six substances below which are regulated by the RoHS directive in Europe are not included in this product. The exception is only lead.

The RoHS directive has some exemptions. The following relates to this product :

Lead in high melting temperature type solders (Sn-Pb solder alloy which contains more than 85%)

This product is used to the high melting temperature type solders (Sn-Pb solders) for die-bonding.
Moreover, the terminals used lead-free solder.

* The six substances regulated by the RoHS Directive are:

Lead, Mercury, Hexavalent chromium, Cadmium, PBB (polybrominated biphenyls),
PBDE (polybrominated diphenyl ethers).

13-2) Compliance with the class-1 ODS and class-2 ODS. (ODS: Ozone-Depleting Substances)

This product does not contain and used the "Law concerning the Protection of the Ozone Layer through the Control of Specified Substances and Other Measures (JAPAN)", and the Montreal Protocol.

This material and the information herein is the property of Fuji Electric Device Technology Co.,Ltd. They shall be neither reproduced, copied, lent, or disclosed in any way whatsoever for the use of any third party nor used for the manufacturing purposes without the express written consent of Fuji Electric Device Technology Co.,Ltd.

- If you have any questions about any part of this Specification, please contact Fuji Electric or its sales agent before using the product.
- Neither Fuji nor its agents shall be held liable for any injury caused by using the products not in accordance with the instructions.
- The application examples described in this specification are merely typical uses of Fuji Electric products.
- This specification does not confer any industrial property rights or other rights, nor constitute a license for such rights.

保守移行機種
Not recommend for new design.