

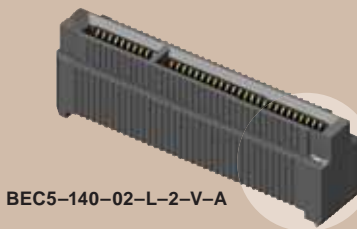

(0,50mm) .0197"

BEC5 SERIES



BEC5-140-02-L-2-V-A

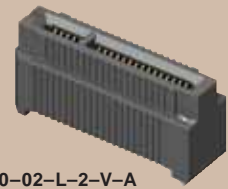

BEC5-120-02-L-2-V-A

# HIGH DENSITY EDGE CARD

## SPECIFICATIONS

For complete specifications and recommended PCB layouts see [www.samtec.com?BEC5](http://www.samtec.com?BEC5)

**Insulator Material:**

Black LCP

**Contact Material:**

BeCu

**Plating:**

Au or Sn over 50µ" (1,27µm) Ni

**Operating Temp Range:**

-55°C to +125°C

**Current Rating:**

1.3A @ 95°C ambient

**Voltage Rating:**

280 VAC

**RoHS Compliant:**

Yes

**Processing:**

Lead-Free Solderable:

Yes

**SMT Lead Coplanarity:**

(0,15mm) .006" max

**Mates with:**

(1,60mm) .062" and

(2,40mm) .094" thick cards

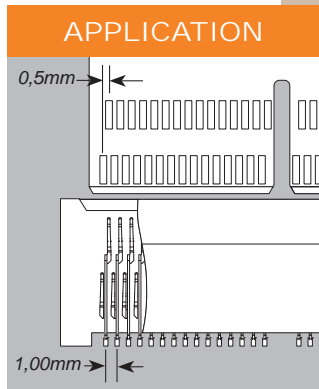

Edge Rate™ contacts

(1,00mm) .03937" x (1,27mm) .050" grid PCB pad layout (4 rows)

Weld Tab



• Solder crimps

Lead-free solder crimps



## ALSO AVAILABLE

- Tin-Lead Solder Charge.
  - Other platings and pin counts.
- Call Samtec.



NO. OF POSITIONS	A	B	C	D	E
-080	(29,00) 1.142	(24,15) .951	(7,08) .279	(25,70) 1.012	(26,50) 1.043
-100	(34,00) 1.339	(29,15) 1.148	(7,08) .279	(30,70) 1.209	(31,50) 1.240
-120	(39,00) 1.535	(34,15) 1.344	(12,08) .475	(35,70) 1.406	(36,50) 1.437
-140	(44,00) 1.732	(39,15) 1.541	(12,08) .475	(40,70) 1.602	(41,50) 1.634

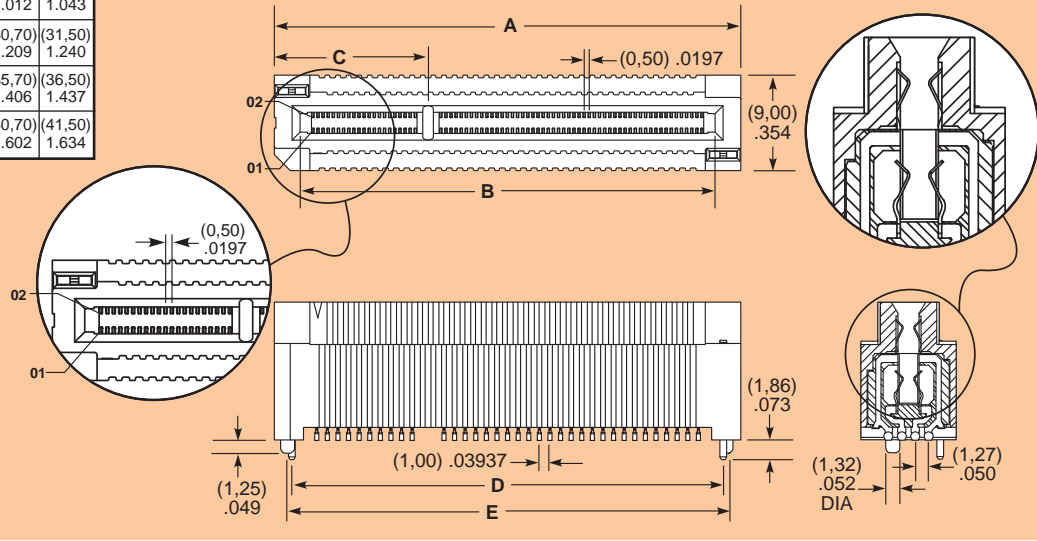

**Note:** May not be suitable for hot plugging application, contact Samtec engineering.

**Note:** Some sizes, styles and options are non-standard, non-returnable.

Due to technical progress, all designs, specifications and components are subject to change without notice.

WWW.SAMTEC.COM