

REV DATE: 8/9/12	DATE	REV.	DESCRIPTION	DR	CK	REL

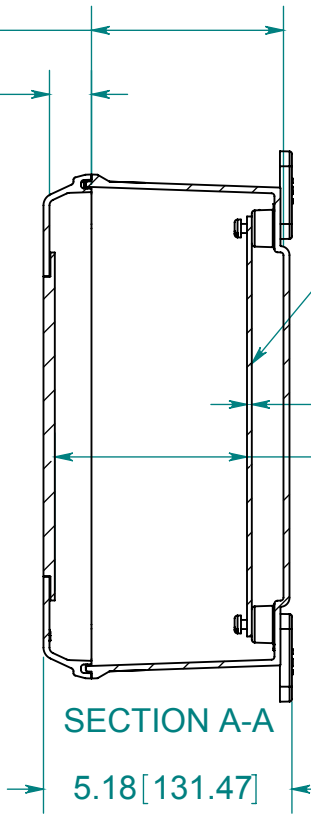

OPTIONAL BACK PANEL  
 0.100 [2.54] TH'K- ALUMINUM  
 0.075 [1.91] TH'K- WHITE STEEL & GALVANNEALED  
 0.125 [3.18] TH'K- FIBERGLASS

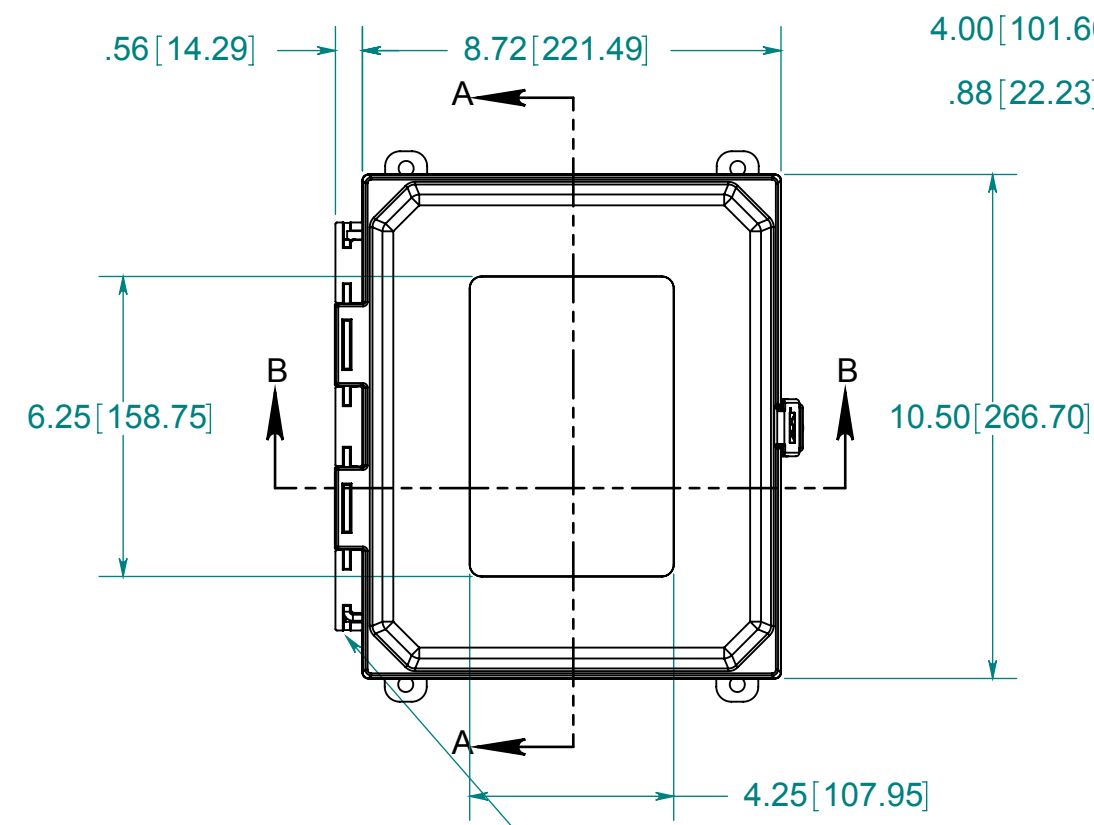
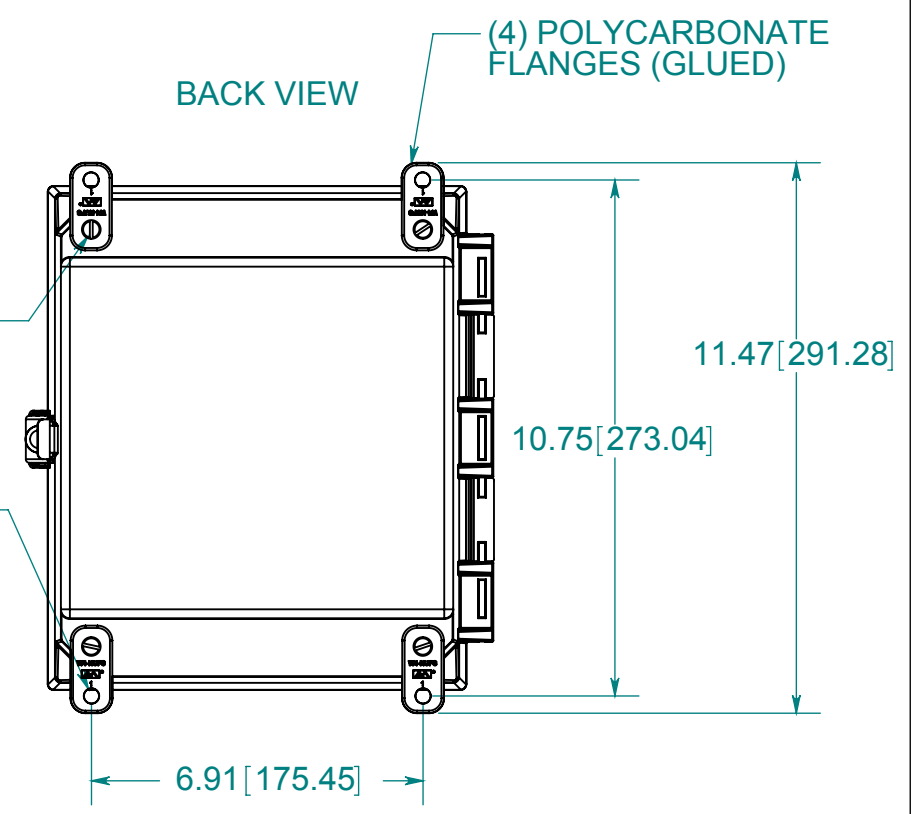

FRONT VIEW WITH COVER REMOVED AND BACK PANEL DISPLAYED

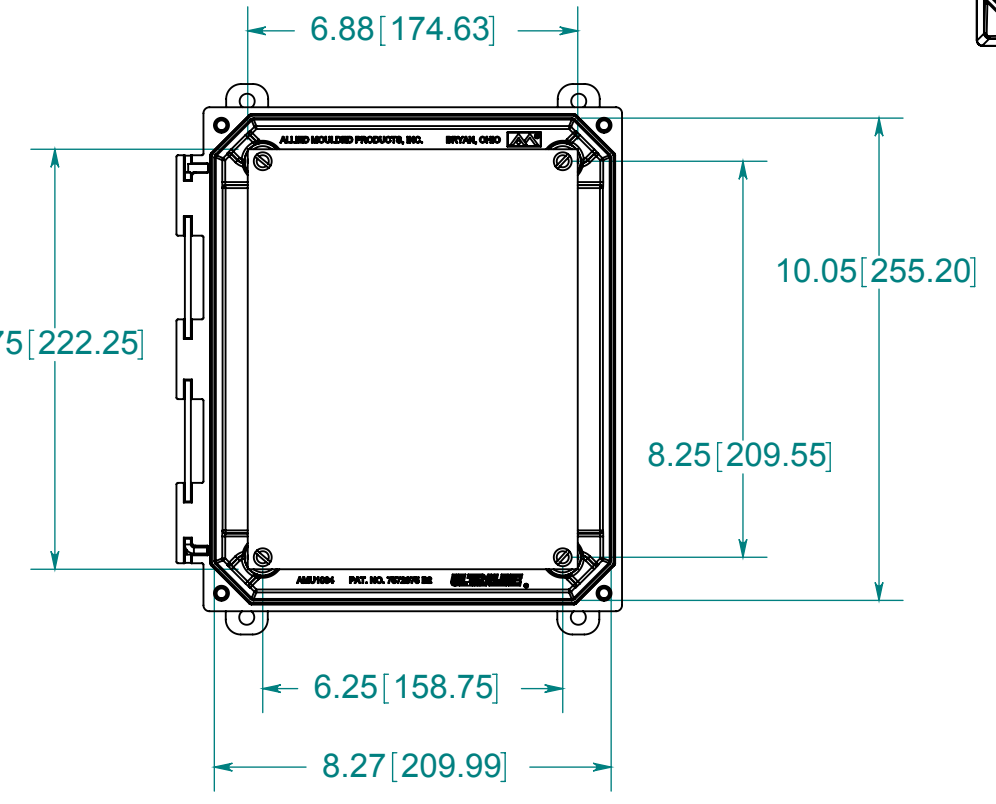

316 STAINLESS STEEL HINGE PIN

316 STAINLESS STEEL LOCKABLE SNAP LATCH LOCATED ON CENTER

CLOSED CELL NEOPRENE GASKET

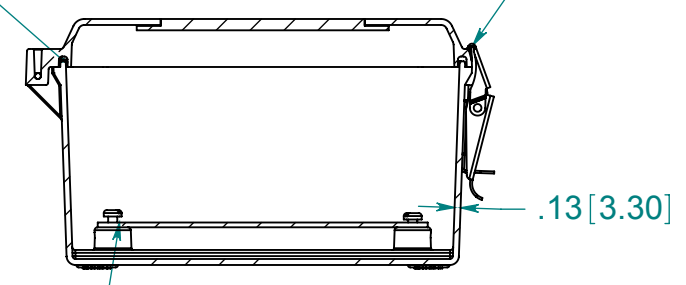

SECTION B-B

(4) EACH #10-32 BRASS INSERTS AND PLATED CARBON STEEL SCREWS

MATERIAL:

BOX-COMPRESSION MOLDED FIBERGLASS REINFORCED POLYESTER  
 COVER- COMPRESSION MOLDED FIBERGLASS REINFORCED POLYESTER  
 CLEAR COVER AND WINDOWS- POLYCARBONATE

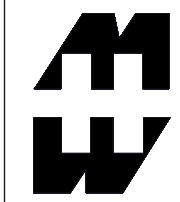

PART No. PJU1084LW  
 for more information visit [www.hammfg.com](http://www.hammfg.com)  
 Data subject to change without notice  
 Drawing Not to Scale