

16-bit Stereo Audio DAC Dual 1.6W Power Amplifiers

FEATURES

- Operation range: 2.4V~5.5V
- 16-bit resolution audio DAC
- Output mode : Speaker(BTL)/Headphone(SE)
- BTL Output power, THD+N<0.16%
R_L=4Ω, 1.6W at 5V, 0.70W at 3.3V, 340mW at 2.4V
R_L=8Ω, 0.83W at 5V, 0.35W at 3.3V, 170mW at 2.4V
- SE Output power, THD+N<0.1%
R_L=32Ω, 46mW at 5V, 20mW at 3.3V, 10mW at 2.4V
- Audio format : I²S, Right justified, Left justified
- Control interface : I²C
- Excellent Power Supply Rejection Ratio(PSRR)
- Flexibility power management
- Component less
- Reduce pop noise circuit
- Housed in TSSOP16 package, enhanced thermal PAD

APPLICATIONS

Multimedia system, Portable Digital Audio.

DESCRIPTION

The MS6336 is a 16-bits voltage-output Digital-to-Analog Converter (DAC) integrated class AB stereo headphone driver and stereo speaker power amplifier. It can drive 1.6W of continuous average power into a dual 4Ω bridged-tied (BTL) speaker or 2 * 46mW into stereo 32Ω single ended (SE) headphone. The 16-bit DAC supports popular formats as I2S, Right Justified, and Left Justified. All of the functions are set by I2C interface.

The MS6336 has good features for portable equipment, including wide voltage operation 2.4V~5.5V, low power consumption, flexible power management, component less and small package TSSOP16, make the MS6336 ideally suitable for use in the portable digital audio equipments.

BLOCK DIAGRAM

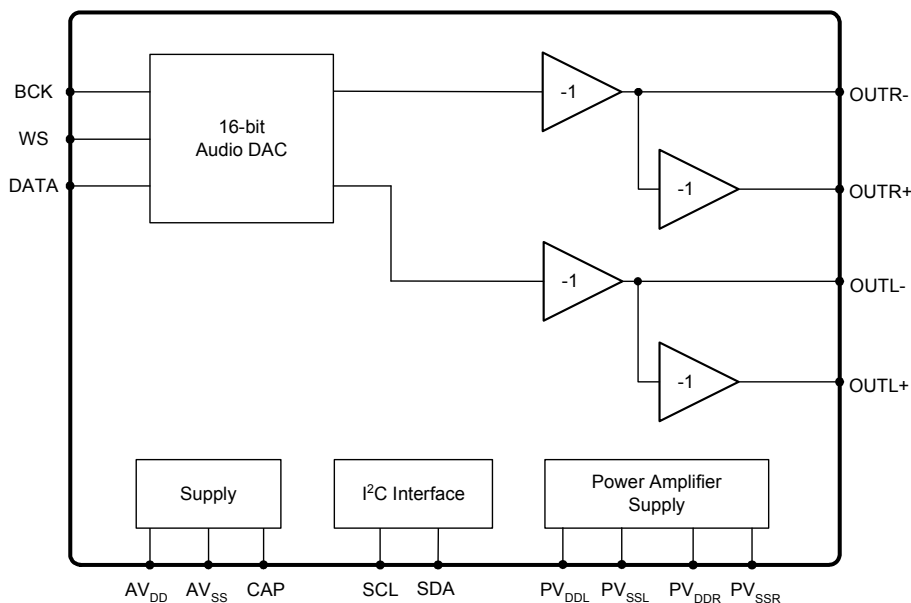

PIN CONFIGURATION

Symbol	Pin	Description
WS	1	Audio word select input
BCK	2	Audio bit clock input
CAP	3	Capacitor connected
AV _{SS}	4	Negative supply voltage
OUTR-	5	SE right channel output or negative output of BTL right channel
PV _{DDR}	6	Positive supply voltage for right channel of power amplifier
OUTR+	7	Positive output of BTL right channel
PV _{SSR}	8	Negative supply voltage for right channel of power amplifier
PV _{SSL}	9	Negative supply voltage for left channel of power amplifier
OUTL+	10	Positive output of BTL left channel
PV _{DDL}	11	Positive supply voltage for left channel of power amplifier
OUTL-	12	SE left channel output or negative output of BTL left channel
AV _{DD}	13	Positive supply voltage
SDA	14	I ² C data input
SCL	15	I ² C clock input
DATA	16	Audio data input

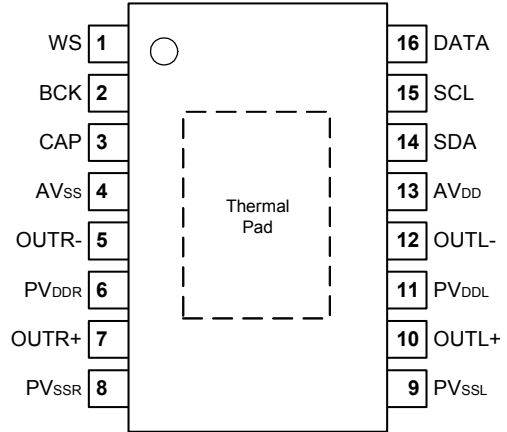

MS6336, TSSOP16

Note: 1. SE: Single Ended. BTL: Bridged-Tied Load

ORDERING INFORMATION

Package	Part number	Packaging Marking	Transport Media
16Pin TSSOP (lead free)	MS6336TGTR	MS6336G	2.5k Units Tape and Reel
16Pin TSSOP (lead free)	MS6336TGU	MS6336G	90 Units Tube

RoHS Compliance

ABSOLUTE MAXIMUM RATINGS

Symbol	Parameter	Rating	Unit
V _{DD}	Supply voltage	6	V
V _{ESD}	Electrostatic handling	2000	V
T _{STG}	Storage temperature range	-65 to 150	°C
T _A	Operating ambient temperature range	-40 to 85	°C
T _J	Maximum junction temperature	150	°C
T _S	Soldering temperature, 10 seconds	260	°C
R _{THJA}	Thermal resistance from junction to ambient in free air TSSOP16 (enhance thermal pad)	51	°C/W

OPERATING RATINGS

Symbol	Parameter	Min	Typ	Max	Unit
V _{DD}	Supply voltage	2.4	5	5.5	V

5V ELECTRICAL CHARACTERISTICS

(T_a=25°C, V_{DD}=5V, V_{SS}=0V, Sampling rate 4fs, fs= 44.1kHz, f=1kHz; unless otherwise specified)

Symbol	Parameter	Conditions	Min	Typ	Max	Unit
DC Characteristics						
V _{CAP}	Voltage at CAP		0.5V _{DD} -0.05	0.5V _{DD}	0.5V _{DD} +0.05	V
V _{DC}	Output DC level		0.5V _{DD} -0.05	0.5V _{DD}	0.5V _{DD} +0.05	V
V _{FSDAC}	Full scale output voltage of DAC	V _{FS} =0.72 * V _{DD}	V _{FS} -1.5%	V _{FS}	V _{FS} +1.5%	V
I _Q	Quiescent current	Audio code 0000H, BTL	-	12.3	-	mA
		Audio code 0000H, SE		9.5		
		L-ch (R-ch) PD, BTL DAC active		8		
		L-ch (R-ch) PD, SE DAC active	-	6.5	-	
I _{PD}	Power down current	All devices power down	-	-	0.3	uA
		All devices power down, except CAP=1/2 VDD		12		
CS	Channel separation	BTL Mode, R _L =8Ω, V _{FS}	-	95	-	dB
		SE Mode, R _L =32Ω, V _{FS}	-	90	-	dB
AC Characteristics						
Res	Resolution		-	-	16	bits
PSRR	Power supply rejection ratio	BTL Mode, R _L =8Ω CAP=1uF, f=200Hz	-	58	-	dB
		SE Mode, R _L =32Ω CAP=1uF, f=200Hz	-	65	-	dB
THD+N	Total harmonic distortion plus Noise	SE mode, R _L =32Ω, V _{FS}	-	-67	-62	dB
			-	0.0447	0.079	%
S/N	Signal-to-noise ratio	SE mode, A-weighting, V _{FS}	86	90	-	dB
P _o	Maximum output power	BTL Mode, R _L = 4Ω THD+N = 0.33%	1.44	1.6	-	W
		BTL Mode, R _L = 8Ω THD+N = 0.15 %	0.75	0.83	-	W
		SE Mode, R _L = 32Ω THD+N = 0.042%	41.4m	46m	-	W
Bus Characteristics						
V _{I2CH}	Serial interface high input level		2	-	-	V
V _{I2CL}	Serial interface low input level		-	-	0.8	V

3.3V ELECTRICAL CHARACTERISTICS

(Ta=25°C, V_{DD}=3.3V, V_{SS}=0V, Sampling rate 4fs, fs= 44.1kHz, f=1kHz; unless otherwise specified)

Symbol	Parameter	Conditions	Min	Typ	Max	Unit
DC Characteristics						
I _Q	Quiescent current	Audio code 0000H, BTL	-	10.9	-	mA
		Audio code 0000H, SE		8.3		
		L-ch (R-ch) PD, BTL DAC active		6.9		
		L-ch (R-ch) PD, SE DAC active	-	5.5	-	
AC Characteristics						
THD+N	Total harmonic distortion plus Noise	SE mode, R _L =32Ω, V _{FS}	-	-65	60	dB
			-	0.0562	0.1	%
P _o	Maximum output power	BTL Mode, R _L = 4Ω THD+N = 0.25%	0.63	0.70	-	W
		BTL Mode, R _L = 8Ω THD+N = 0.14 %	0.32	0.35	-	W
		SE Mode, R _L = 32Ω THD+N = 0.052%	18m	20m	-	W

2.4V ELECTRICAL CHARACTERISTICS

(Ta=25°C, V_{DD}=2.4V, V_{SS}=0V, Sampling rate 4fs, fs= 44.1kHz, f=1kHz; unless otherwise specified)

Symbol	Parameter	Conditions	Min	Typ	Max	Unit
DC Characteristics						
I _Q	Quiescent current	Audio code 0000H, BTL	-	9.6	-	mA
		Audio code 0000H, SE		6.8		
		L-ch (R-ch) PD, BTL DAC active		5.8		
		L-ch (R-ch) PD, SE DAC active	-	4.7	-	
AC Characteristics						
THD+N	Total harmonic distortion plus Noise	SE mode, R _L =32Ω, V _{FS}	-	-63	-58	dB
			-	0.071	0.126	%
P _o	Maximum output power	BTL Mode, R _L = 4Ω THD+N = 0.85%	0.31	0.34	-	W
		BTL Mode, R _L = 8Ω THD+N = 0.17 %	0.15	0.17	-	W
		SE Mode, R _L = 32Ω THD+N = 0.07%	9m	10m	-	W

TYPICAL PERFORMANCE CHARACTERISTICS

(Ta=25°C, sampling rate=4fs, fs= 44.1kHz; unless otherwise specified)

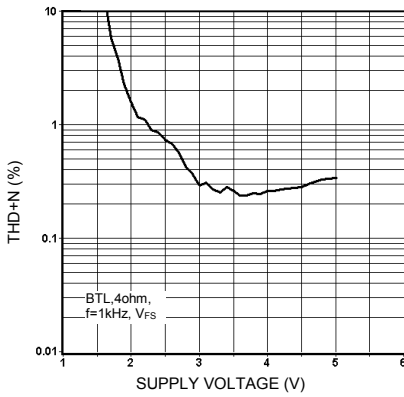

THD+N vs. supply voltage

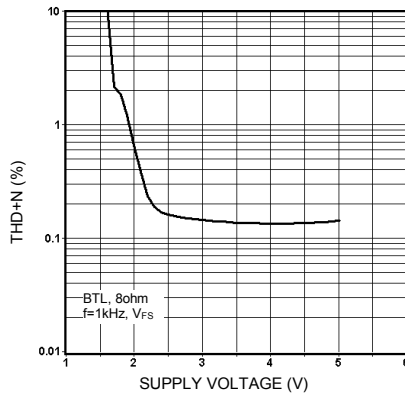

THD+N vs. supply voltage

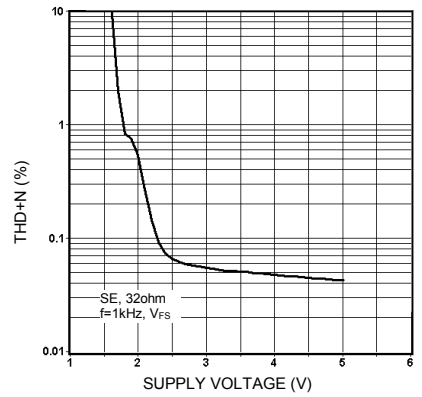

THD+N vs. supply voltage

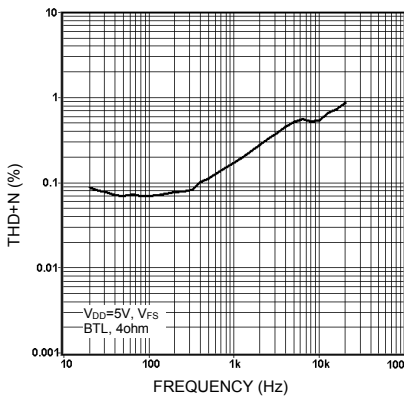

THD+N vs. frequency

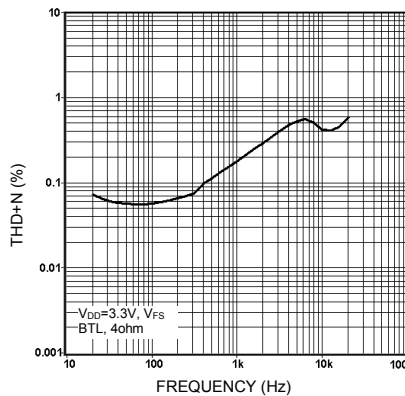

THD+N vs. frequency

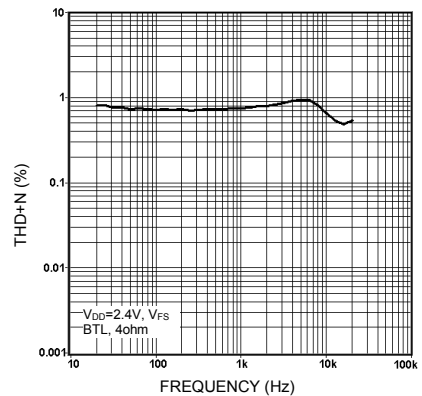

THD+N vs. frequency

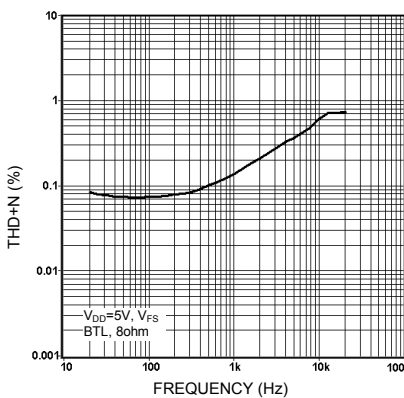

THD+N vs. frequency

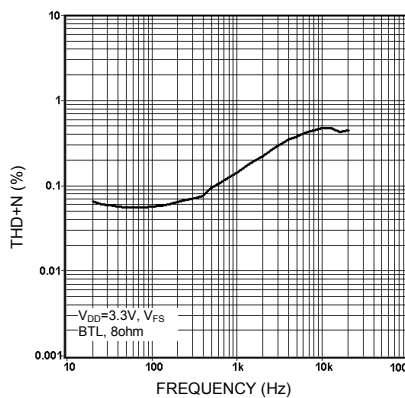

THD+N vs. frequency

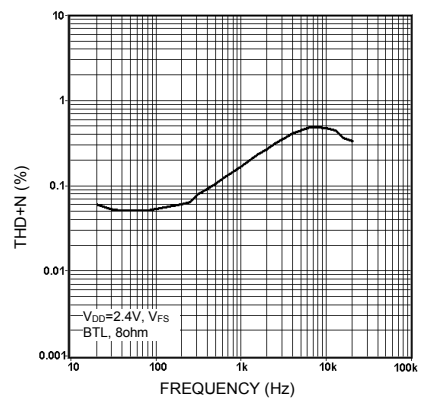

THD+N vs. frequency

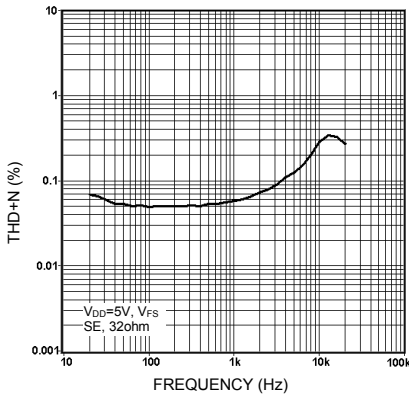

THD+N vs. frequency

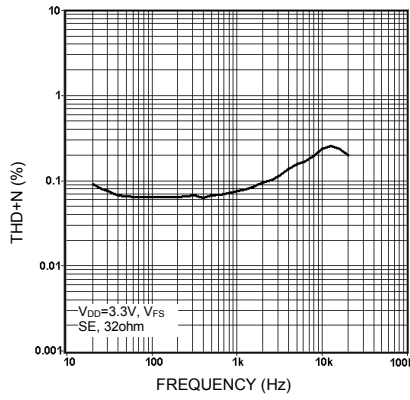

THD+N vs. frequency

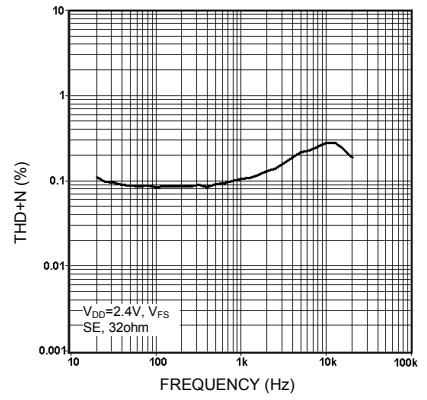

THD+N vs. frequency

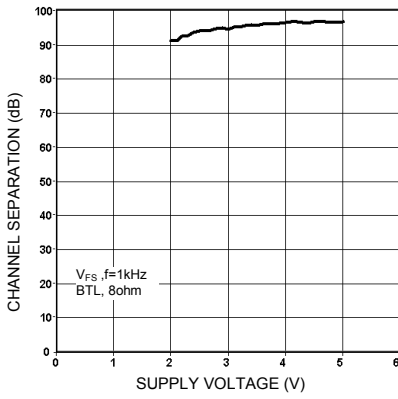

Channel separation vs. supply voltage

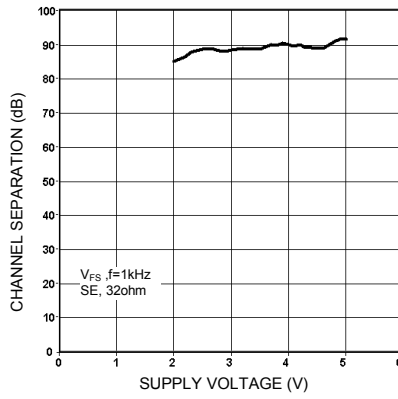

Channel separation vs. supply voltage

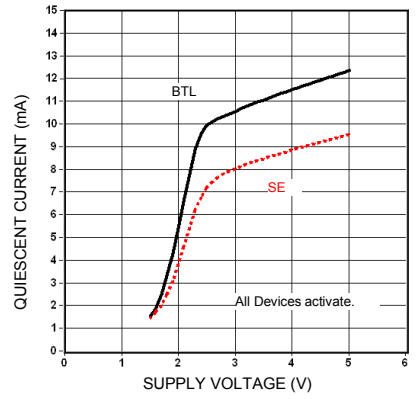

Quiescent current vs. supply voltage

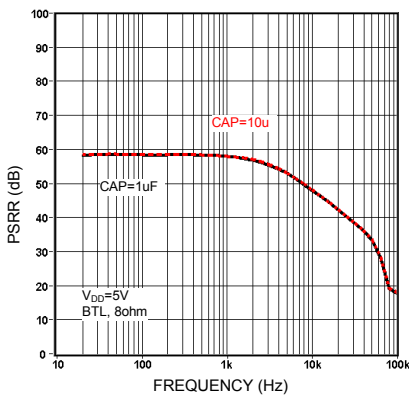

PSRR vs. frequency

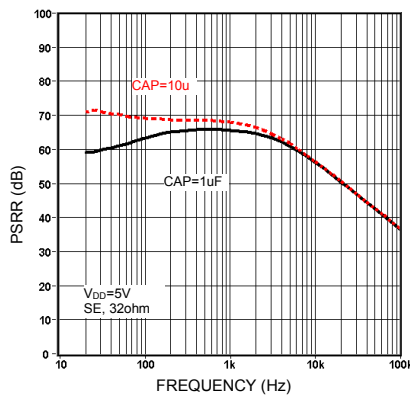

PSRR vs. frequency

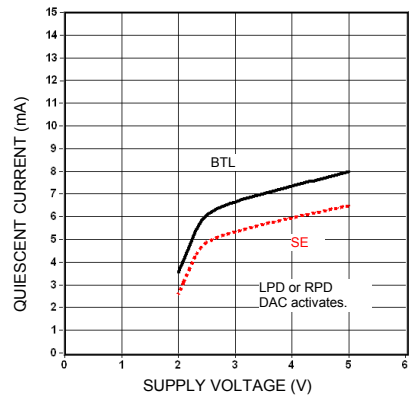

Quiescent current vs. supply voltage

AUDIO TIMING AND FORMAT

The MS6336 accepts input serial data formats of 16-bit word length. Left and right data words are time multiplexed. The MSB must always be first.

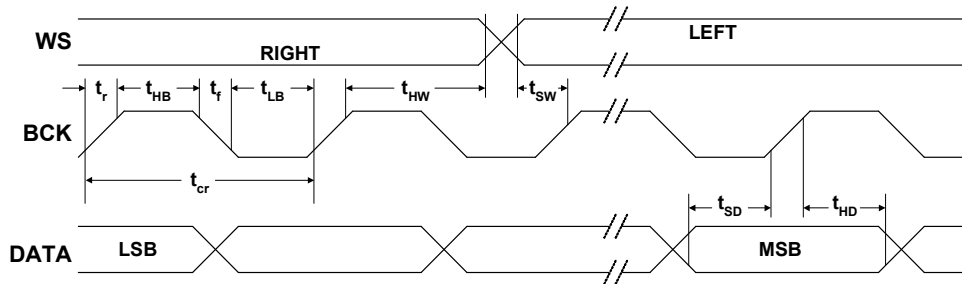

Audio data format (BCK, WS, DATA)

Symbol	Parameter	Conditions	Min	Typ	Max	Unit
V _{IL}	Input LOW level		2	-	-	V
V _{IH}	Input HIGH level		-	-	0.8	V
f _{BCK}	Input Clock Frequency		-	-	18.4	MHz
BR	Bit Rate Data Input		-	-	18.4	Mbits/s
f _{WS}	Word Select Input		-	-	384	kHz
t _r	Rise Time		-	-	12	ns
t _f	Fall Time		-	-	12	ns
t _{cr}	Bit Clock Cycle Time		54	-	-	ns
t _{HB}	Bit Clock High Time		15	-	-	ns
t _{LB}	Bit Clock Low Time		15	-	-	ns
t _{SD}	Data Set-up Time		12	-	-	ns
t _{HD}	Data Hold Time to Bit Clock		2	-	-	ns
t _{HW}	Word Select Hold Time		2	-	-	ns
t _{SW}	Word Select Set-up Time		12	-	-	ns

Right justified format

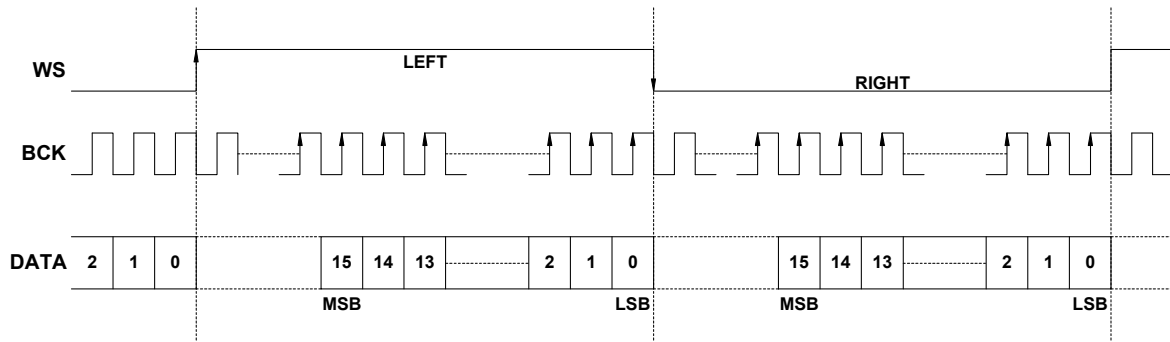

Left justified format

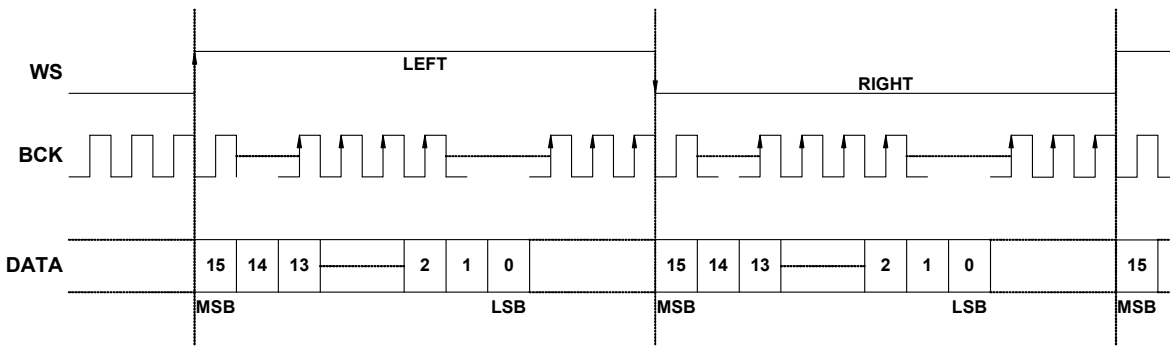

I2S format

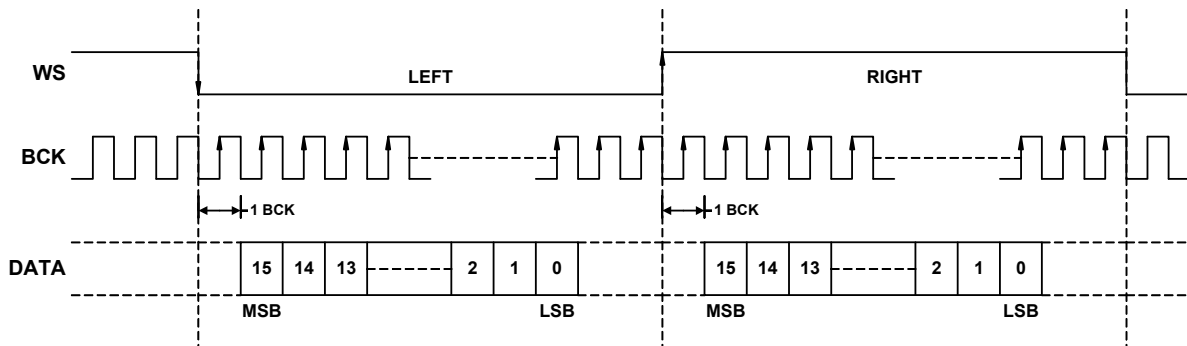

I²C CONTROL INTERFACE

Data are transmitted to and from the MCU and MS6336 via the SDA and SCL. The SDA and SCL make up the BUS interface. It should be noted that pull-up resistors must be connected to the positive supply voltage.

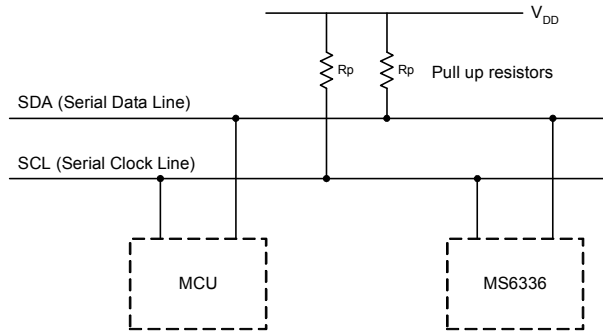

I²C interface protocol

The format consists of the following:

- A START condition
- A chip address byte including the chip address. (7bits)
- The 8th bit of the byte must be "0".(write=0, read=1)
- The chip must always acknowledge the end of each transmitted byte.
- A data sequence (N-bytes + Acknowledge)
- A STOP condition

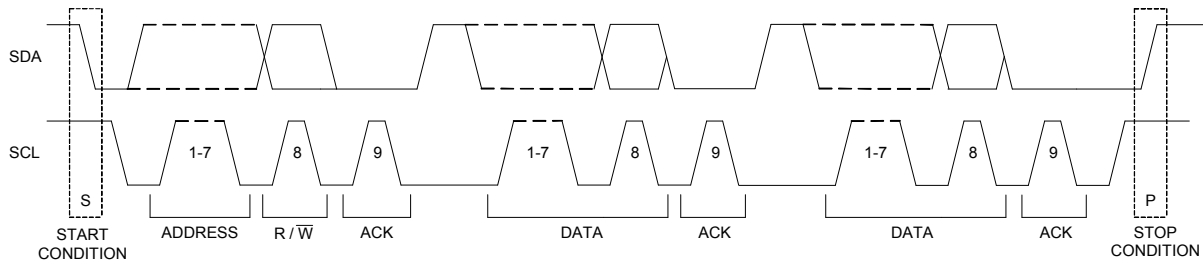

I²C chip address

88H

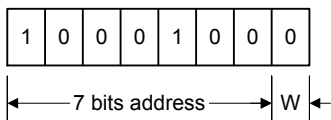

I²C data bytes description

MSB			LSB					Function
1	1	0	DAC PD	LPD	RPD	PDPR	CAP PD	Power Down Mode
1	1	1	S/B	DAC Mute	DAC Mute	AF1	AF0	Output mode (SE/BTL), DAC mute, and Audio format

Power Down Mode								
MSB			LSB				Function	
1	1	0	DAC PD	RPD	LPD	PDPR	CAP PD	Power mode selection and power management
			0					DAC is active mode
			1					DAC is power down mode
				0				R-ch PA output is active mode
				1				R-ch PA output is power down mode
					0			L-ch PA output is active mode
					1			L-ch PA output is power down mode
						0		Disable preparation for power off
						1		Enable preparation for power off
							0	Set the voltage of CAP to middle of supply voltage
							1	Pull down CAP pin to ground

Initial state: All are the power down modes.

Enable the power down preparation before the chip will be shut down.

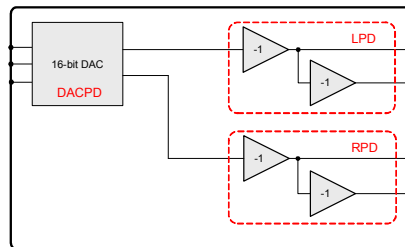

Output mode (SE/BTL), DAC mute and Audio format								
MSB			LSB				Function	
1	1	1	S/B	DAC Mute	DAC Mute	AF1	AF0	Output mode and audio format
			0					Output mode is BTL
			1					Output mode is SE
				0	0			DAC is mute-on
				1	1			DAC is mute-off
						0	0	Right justified format
						1	0	Left justified format
						0	1	I ² S format
						1	1	

Initial state: Output mode is BTL mode, DAC is mute-on and right justified format

Initial chip status

MSB							LSB	Function
1	1	0	1	1	1	1	1	Power Down Mode
1	1	1	0	0	0	0	0	Output mode (SE/BTL), DAC mute, and Audio format

I²C CODE EXAMPLE

Power down mode

Set the built-in DAC to be power down mode.

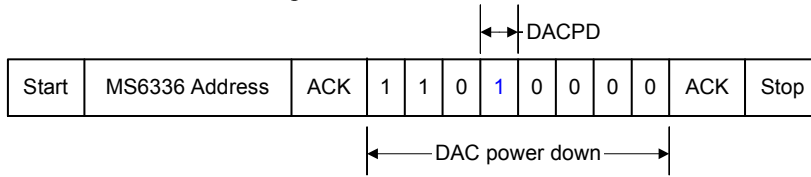

Output mode and audio format

Set the output mode to be BTL mode, and the DAC to be mute-off, I2S format.

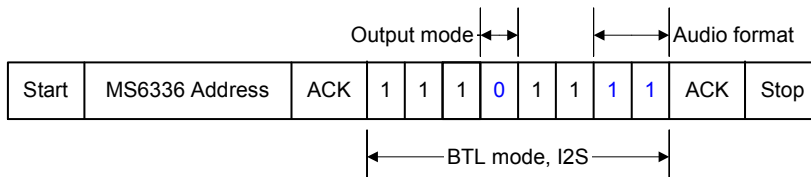

OPERATION PROCEDURE

The sequence of operation: power on → active → power down → active → power off. The basic flowcharts are as follows:

For HP mode and HP/BTL mode

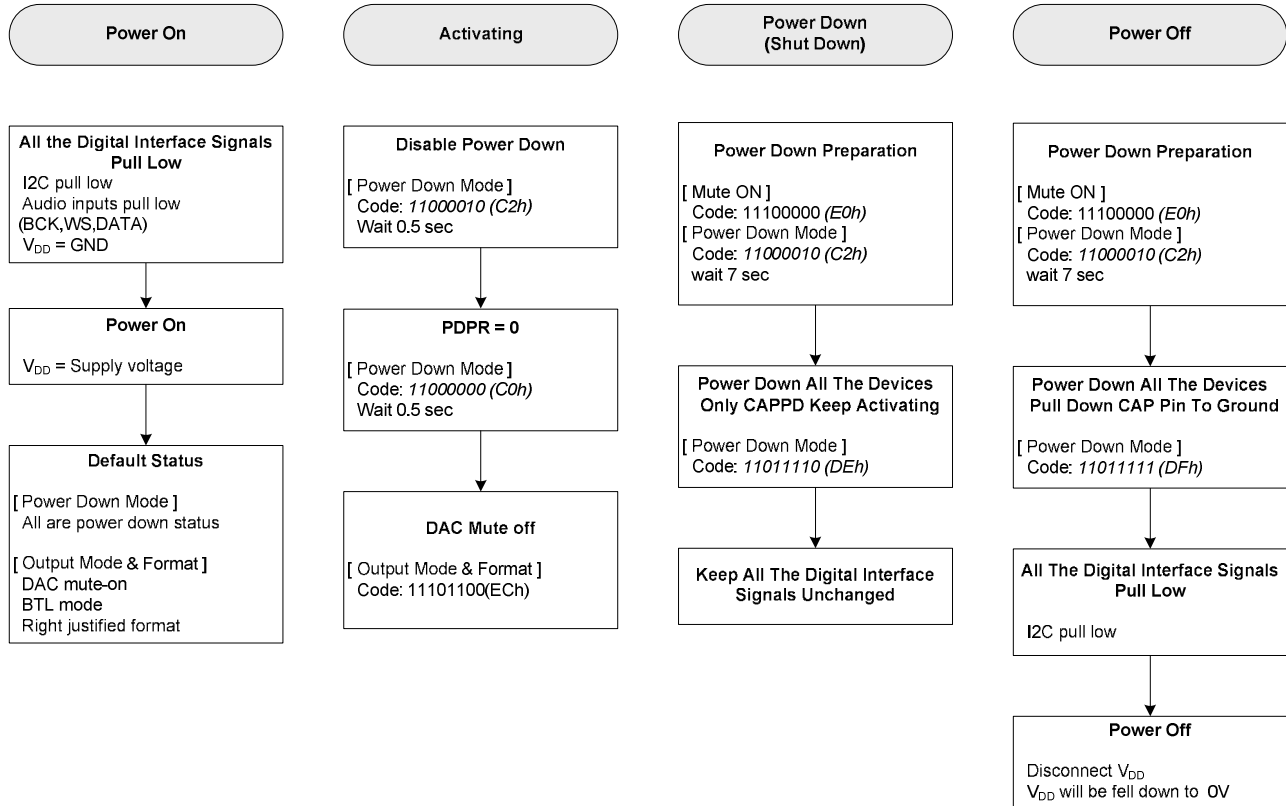

For BTL mode only

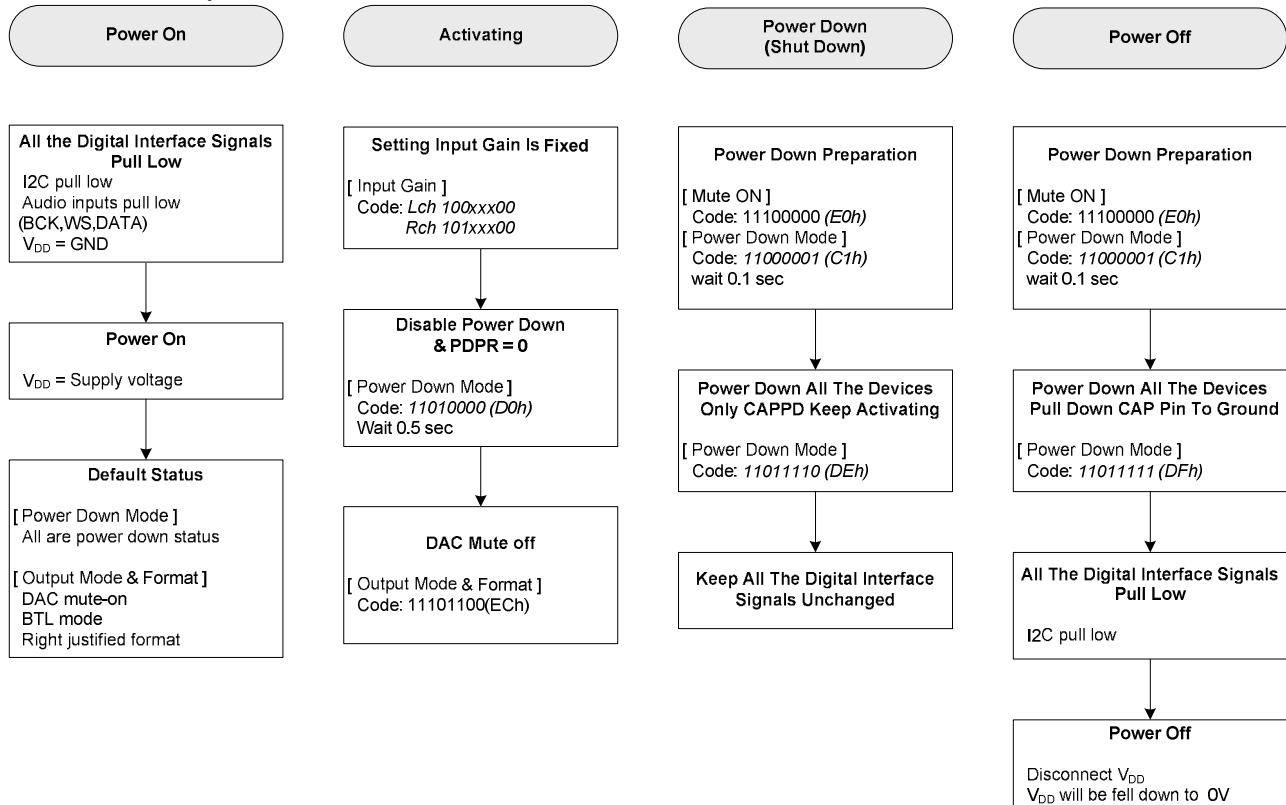

APPLICATION INFORMATION

A base application circuit

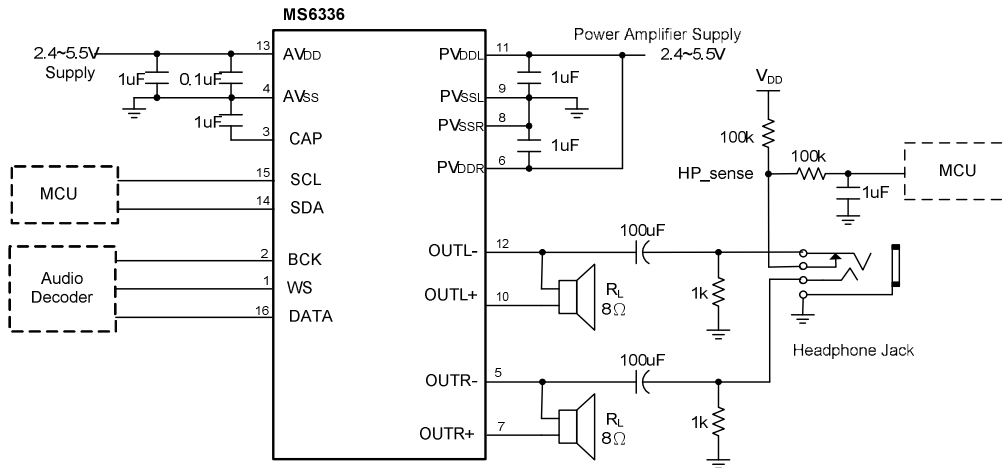

Output mode operation -- SE mode and BTL mode

The output has two modes, SE mode and BTL mode. The mode is selected by I2C code via MCU. In BTL mode, the outputs of A1(B1) and A2(B2) are then used to drive the speakers(4Ω/8Ω).

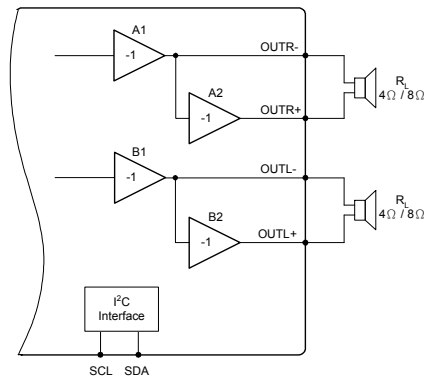

In the SE mode, the amplifiers A2 and B2 are shutdown, and become the high output impedance states.

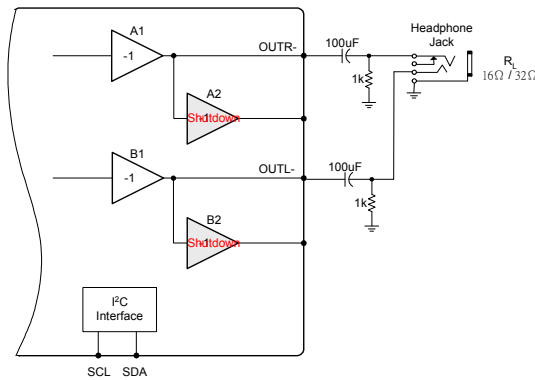

Headphone sense

The output mode is SE or BTL that is decided by a headphone. It has to be set SE mode when a headphone is plug-in status. The output mode is selected by I2C command code by MCU. Please note that the MS6336 don't detect a headphone automatically. Thus a detect function is executed via MCU. An operation diagram is shown as follows:

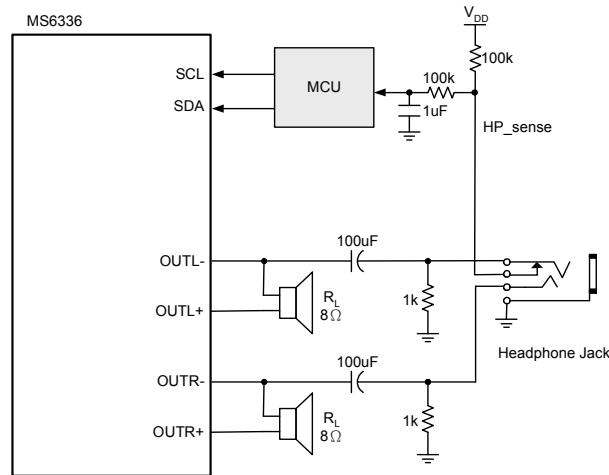

The HP_sense pin is high when a headphone is plug-in.
 The HP_sense pin is low when a headphone is not plug-in.

EXTERNAL DIMENSIONS

TSSOP16 (Thermal Pad)

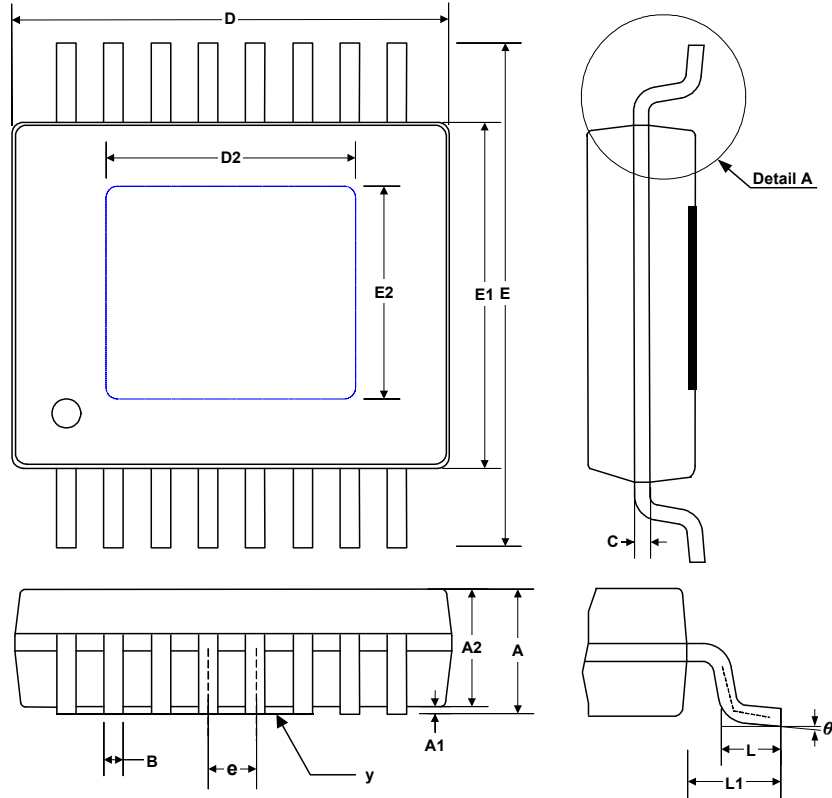

Symbol	Dimension in mm			Dimension in inches		
	Min	Nom	Max	Min	Nom	Max
A	-	-	1.15	-	-	0.045
A1	0.00	-	0.10	0.000	-	0.004
A2	0.80	1.00	1.05	0.031	0.039	0.041
b	0.19	-	0.30	0.007	-	0.012
C	0.09	-	0.20	0.004	-	0.008
D	4.90	5.00	5.10	0.193	0.197	0.201
D2	3.7	3.8	3.9	0.146	0.150	0.154
E	6.20	6.4	6.60	0.244	0.252	0.260
E1	4.30	4.40	4.50	0.169	0.173	0.177
E2	2.7	2.8	2.9	0.106	0.110	0.114
e	-	0.65	-	-	0.026	-
L	0.45	0.60	0.75	0.018	0.024	0.030
L1	0.90	1.00	1.10	0.035	0.039	0.043
θ	0°	-	8°	0°	-	8°
y	-	-	0.10	-	-	0.004

DEMO BOARD

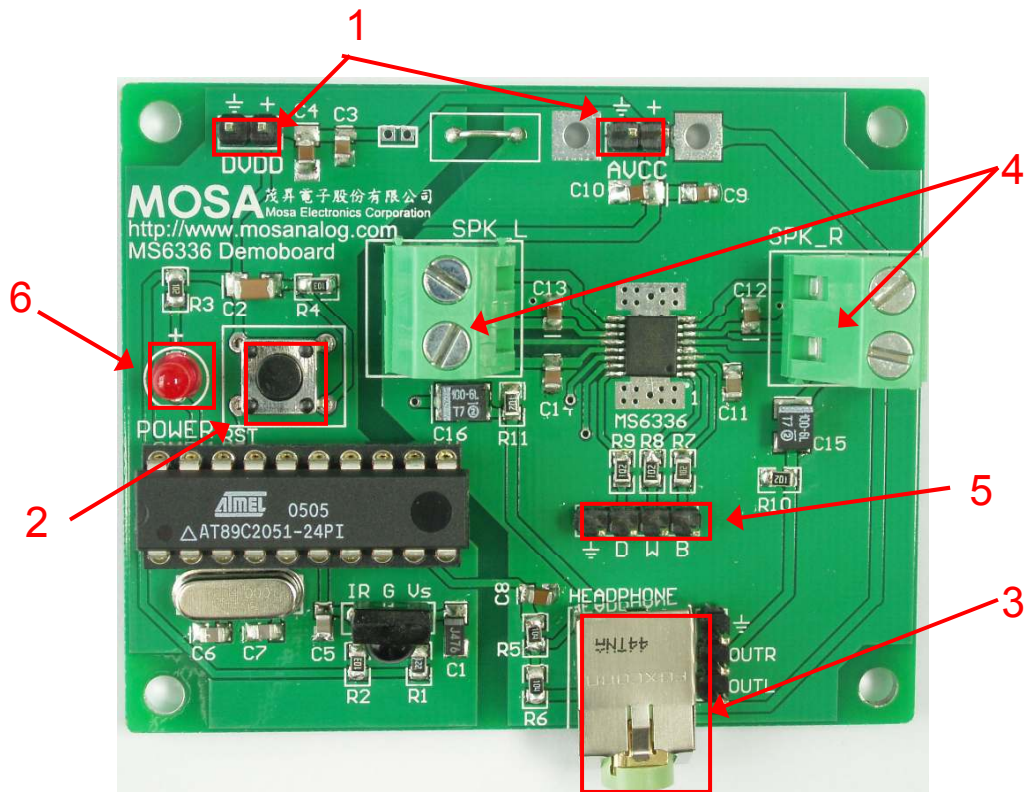

Function description

Label 1: Supply Input
Supply voltage range is 2.4V to 5.5V.

Label 2: Reset
All I/O pins are reset to default values.

Label 3: Headphone Jack
Used 3.5mm diameter of headphone with 32ohm

Label 4: Speaker Output
Connected to speaker with 8ohm or 4 ohm

Label 5: Digital Signal Input
Connected to digital audio formats as I2S, Right Justified and Left Justified.

Label 6: LED Indicator
The LEDs indicate the chip status and IR received status. It keeps on a light state when the MS6336 is active. The other hand, keeps on a dark state when the MS6336 is power-off. It is red-dark blink once when the MCU has received the function code correctly.

SE mode and BTL mode operation

The headphone controls operational mode. System enters SE mode when headphone jack is empty. When a set of headphone plugged into the jack, the system switched to BTL mode.

IR Controller

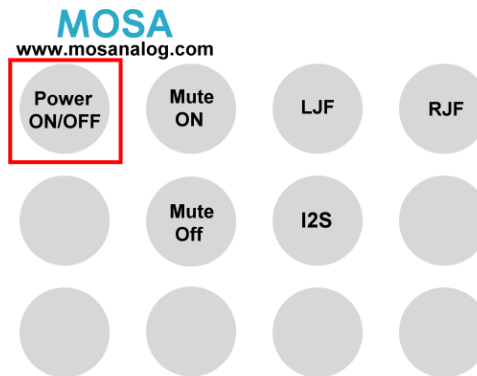

MS6336

16-bit Audio DAC integrated Dual 2W Power Amplifiers

Power ON/OFF : The system power keys.

Power ON, the chip is activating when the LED indicator is on a light state.
Power OFF, the chip is power-off when the LED indicator is on a dark state.

Mute ON/OFF : The mute keys.

Mute ON, the output channels are no signals in mute state.
Mute OFF, the output channels are normal.

I2S, LJF, RJF: The digital input format keys.

There are three formats can be selected that is I2S, Left justified and Right justified.

Circuit

