



4D SYSTEMS
TURNING TECHNOLOGY INTO ART

4Display Shields

4Display-Shield-96/128/160/144

DATASHEET

Document Date: 6th September 2012
Document Revision: 1.0

Contents

1. Description.....	3
2. Features	4
3. Hardware Description	5
3.1. 4Display-Shield-96 Arduino Shield – Featuring a 4D Systems μ OLED-96-G2	5
3.2. 4Display-Shield-128 Arduino Shield – Featuring a 4D Systems μ OLED-128-G2	6
3.3. 4Display-Shield-160 Arduino Shield – Featuring a 4D Systems μ OLED-160-G2	7
3.4. 4Display-Shield-144 Arduino Shield – Featuring a 4D Systems μ LCD-144-G2	8
3.5. Jumper Settings.....	9
4. Related Products.....	10
5. Schematic Design	11
6. Specifications and Ratings.....	12
7. Legal Notice	13
8. Contact Information.....	13

1. Description

The 4Display-Shield provides an easy way of interfacing 4D Systems display modules to the Arduino-Duemilanove, the Arduino-Mega and many other Arduino compatible boards. The 4Display-Shields come in 4 models, featuring a 5 way multiswitch joystick and male headers that help connect the 4Display-Shield to the Arduino boards. The 5 position joystick is connected to the Arduino D2, D3, D4, D5 and D6 pins. The communication interface between the 4Display-Shield and the Arduino is via the Serial UART. Both the TX and RX signals are jumpered on the shield PCB so that the Arduino UART can be freed-up when it's being programmed.

The 4Display-Shield can be purchased in four models, featuring one of the following displays:

- μ OLED-96-G2
- μ OLED-128-G1 (or μ OLED-128-G2)
- μ OLED-160-G1 (or μ OLED-160-G2)
- μ LCD-144-G2

These feature packed display modules, coupled with a convenient Arduino Shield, makes an ideal platform for learning and experimenting with the 4D Systems display modules.

The 4Display-Shield is integrated with a full colour OLED or TFT LCD screen (model dependant), tiny yet powerful GOLDELOX graphics processors and a micro-SD connector which supports standard and high-capacity memory cards. The memory card can be used to store images, icons, video clips and data logging.

The 4D Systems display module on the 4Display-Shield can be programmed as a stand-alone controller, or as a serial slave to the Arduino. To change how the display module is programmed, simply download the 4D Systems Workshop 4 IDE software from the 4D systems website, www.4dsystems.com.au, and follow the on screen instructions.

When configured as a serial slave, the Arduino takes the role of the host controller. This allows you to develop your graphics applications using the Arduino development environment and software tools. The GOLDELOX processor has a rich set of serial commands built inside the chip and the commands are sent from the Arduino via the serial (UART) interface. All it takes is a few bytes of serial data from the Arduino and you can quickly

and easily draw lines, circles, text and even display Images as well as play Video clips.

The following links (not affiliated to 4D Systems) may prove useful when configuring the 4Display-Shield as a serial slave:

<http://embeddedcomputing.weebly.com/serial-lcd.html>
<http://jennylc.com/4d/>
http://nicholasboka.com/?page_id=23
<http://code.google.com/p/displayshield4d/>
<http://code.google.com/p/uoled-library/>

When configured as a stand-alone processor, the 4Display-Shield becomes a stand-alone device and all display application code is written in the Workshop 4 IDE, using the 4DGL Language. Don't let the name scare you off, 4DGL is an easy to learn but a powerful high level language. It allows the developer to write applications in a high level syntax similar to popular languages such as BASIC, C and Pascal and run it directly on the GOLDELOX processor. If you can write Arduino code then you can certainly write 4DGL code. The display modules are stand-alone devices. It allows the user to take complete control of all available resources on the display module such as the Serial Port, the graphics display and the micro-SD memory card. Thus graphics intensive processes can be completely offloaded from the Arduino and run on the GOLDELOX processor, along with micro-SD card processes and access to the GOLDELOX I/O pins. It provides the user complete control over the display module allowing them to offload a lot of overhead from the host processor by creating the 'work horse' objects within the display module itself.

So, for a game of Tetris, rather than sending all the tetris graphics objects (tile blocks, borders, game score, etc etc), as serial graphics primitives, entire functions can be created in 4DGL and receive simple serial commands to control them. This also gives a neat division between the graphics functions and the game itself, allowing changes in the games appearance without altering the main Arduino game code, effectively allowing you to 'change skins' for the games appearance.

2. Features

- On-board micro-SD memory card adaptor for storing of icons, images, animations, etc. Supports standard and high capacity (HC-SD) memory cards.
- 5-Way multifunction Joystick switch directly connected to Arduino D2, D3, D4, D5 and D6 pins.
- Powered from the Arduino board, uses the 5V supply pin.
- RoHS Compliant.

4Display-Shield-96

- 4D Systems μ OLED-96-G2 Display Module
- 96 x 64 resolution, 65K true to life colours, PMOLED screen.
- 0.96" diagonal size, Viewing Area: 20mm x 14mm.
- No back lighting with near 180° viewing angle.

4Display-Shield-128

- 4D Systems μ OLED-128-G1 (or μ OLED-128-G2) Display Module
- 128 x 128 resolution, 65K true to life colours, PMOLED screen.
- 1.5" diagonal size, Viewing Area: 27mm x 27mm.
- No back lighting with near 180° viewing angle.

4Display-Shield-160

- 4D Systems μ OLED-160-G1 (or μ OLED-160-G2) Display Module
- 160 x 128 resolution, 65K true to life colours, PMOLED screen.
- 1.7" diagonal size, Viewing Area: 33.6mm x 27mm.
- No back lighting with near 180° viewing angle.

4Display-Shield-144

- 4D Systems μ LCD-144-G2 Display Module
- 128 x 128 resolution, 65K true to life colours, LCD-TFT screen.
- 1.44" diagonal size, Viewing Area: 25.5mm x 26.5mm.
- LED back lighting with greater than 150° viewing angle.

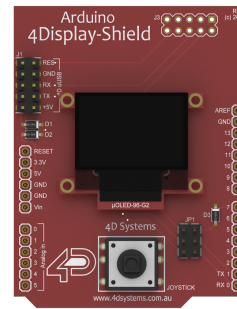

4Display-Shield-96 Arduino Shield

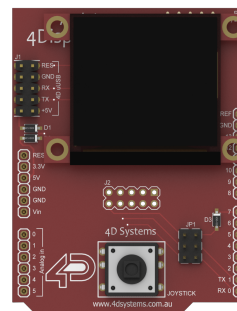

4Display-Shield-128 Arduino Shield

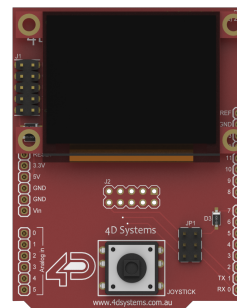

4Display-Shield-160 Arduino Shield

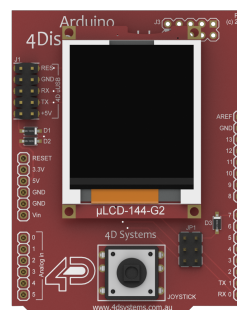

4Display-Shield-144 Arduino Shield

3. Hardware Description

3.1. 4Display-Shield-96 Arduino Shield – Featuring a 4D Systems μ OLED-96-G2

The 4Display-Shield-96 is an Arduino Shield featuring a 4D Systems μ OLED-96-G2 display module, and a joystick for a user interface.

The 4Display-Shield-96 provides a simple serial interface between the Arduino platform and the 4D Systems display, allowing rapid hardware prototyping and development.

Programming the 4Display-Shield-96 with the 4D Systems Workshop 4 Software is required to get started, and there the user can choose the programming environment to use.

Workshop 4 provides the user with 3 programming environments, to give the freedom of choice for how the display module will be configured.

Please refer to the Datasheet of the μ OLED-96-G2 display module for further information, available from the 4D Systems website, www.4dsystems.com.au

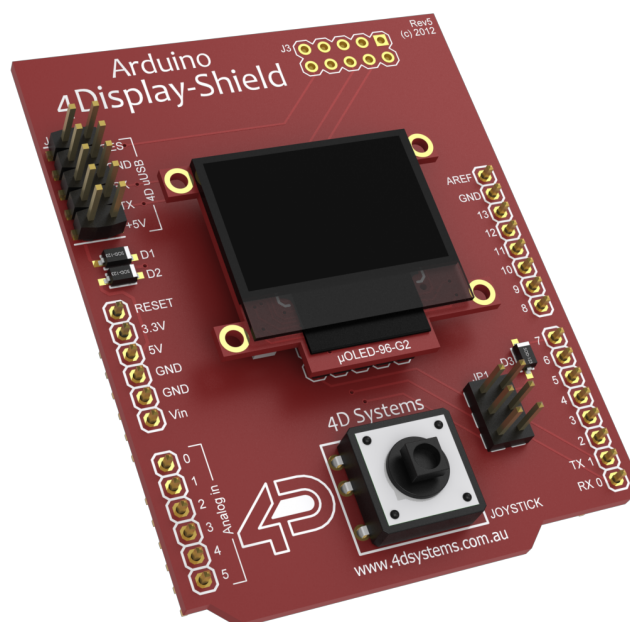

The Designer environment of the 4D Systems Workshop 4 software, enables the full display power of the μ OLED-96-G2 display module to be harnessed. This is where 4DGL logic is written in its natural form, and enables the user to make this 4Display-Shield into a controller, along with simply being a display to the Arduino. Please refer to the **“4DGL-Programmers-Reference-Manual.pdf”** and **“GOLDELOX-4DGL-Internal-Functions.pdf”** documents for more information on the 4DGL programming language.

The ViSi environment enables a visual programming experience for the user to quickly create a display using drag-and-drop objects. The user can simply lay the objects on the display and generate 4DGL code automatically for those objects. The user then manipulates this code the 4DGL codespace to further configure based on the users application requirements. This environment allows the user to immediately see what the display will look like once programmed.

The Serial environment enables the display to turn into a slave serial display, allowing all development to be done in the Arduino IDE. Writing commands from the Arduino and sending them over the Serial port, will enable the user to draw primitives, text, play video, animations and much more. This is the most common environment used for Arduino users. Please refer to the **“Workshop-4-IDE-User-Manual.pdf”** documentation for further information on the commands available.

3.2. 4Display-Shield-128 Arduino Shield – Featuring a 4D Systems μ OLED-128-G2

The 4Display-Shield-128 is an Arduino Shield featuring a 4D Systems μ OLED-128-G1 (or μ OLED-128-G2) display module, and a joystick for a user interface.

The 4Display-Shield-128 provides a simple interface between the Arduino platform and the 4D Systems display, allowing rapid hardware prototyping and development.

Programming the 4Display-Shield-128 with the 4D Systems Workshop 4 Software is required to get started, and there the user can choose the programming environment to use.

Workshop 4 provides the user with 3 programming environments, to give the freedom of choice for how the display module will be configured.

Please refer to the Datasheet of the μ OLED-128-G1/G2 display module for further information, available from the 4D Systems website, www.4dsystems.com.au

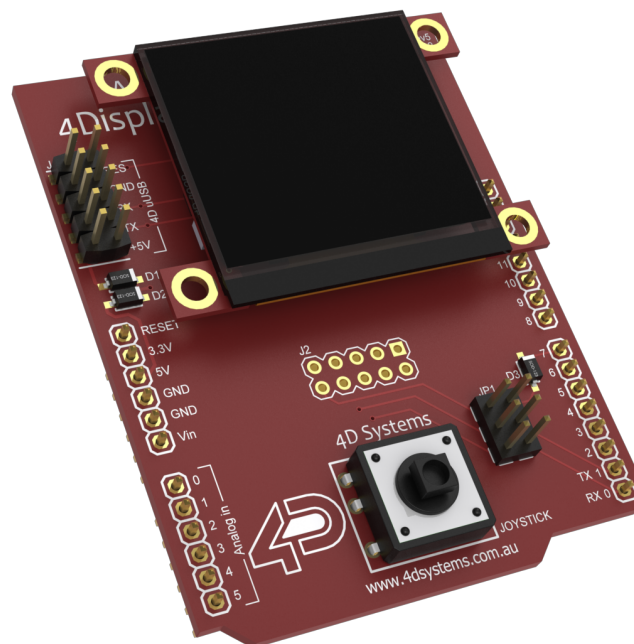

The Designer environment of the 4D Systems Workshop 4 software, enables the full display power of the μ OLED-128-G1/G2 display module to be harnessed. This is where 4DGL logic is written in its natural form, and enables the user to make this 4Display-Shield into a controller, along with simply being a display to the Arduino. Please refer to the “[4DGL-Programmers-Reference-Manual.pdf](#)” and “[GOLDELOX-4DGL-Internal-Functions.pdf](#)” documents for more information on the 4DGL programming language.

The ViSi environment enables a visual programming experience for the user to quickly create a display using drag-and-drop objects. The user can simply lay the objects on the display and generate 4DGL code automatically for those objects. The user then manipulates this code the 4DGL codespace to further configure based on the users application requirements. This environment allows the user to immediately see what the display will look like once programmed.

The Serial environment enables the display to turn into a slave serial display, allowing all development to be done in the Arduino IDE. Writing commands from the Arduino and sending them over the Serial port, will enable the user to draw primitives, text, play video, animations and much more. This is the most common environment used for Arduino users. Please refer to the “[Workshop-4-IDE-User-Manual.pdf](#)” documentation for further information on the commands available.

Note: 4Display-Shield-128 modules will start shipping with μ OLED-128-G2 instead of μ OLED-128-G1 modules without warning or notice. No operational differences exist with respect to this Arduino Shield.

3.3. 4Display-Shield-160 Arduino Shield – Featuring a 4D Systems μ OLED-160-G2

The 4Display-Shield-160 is an Arduino Shield featuring a 4D Systems μ OLED-160-G1 (or μ OLED-160-G2) display module, and a joystick for a user interface.

The 4Display-Shield-160 provides a simple interface between the Arduino platform and the 4D Systems display, allowing rapid hardware prototyping and development.

Programming the 4Display-Shield-160 with the 4D Systems Workshop 4 Software is required to get started, and there the user can choose the programming environment to use.

Workshop 4 provides the user with 3 programming environments, to give the freedom of choice for how the display module will be configured.

Please refer to the Datasheet of the μ OLED-160-G1/G2 display module for further information, available from the 4D Systems website, www.4dsystems.com.au

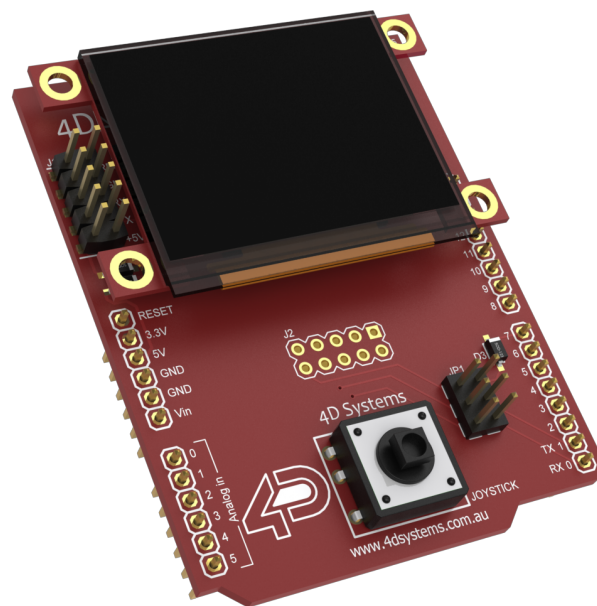

The Designer environment of the 4D Systems Workshop 4 software, enables the full display power of the μ OLED-160-G1/G2 display module to be harnessed. This is where 4DGL logic is written in its natural form, and enables the user to make this 4Display-Shield into a controller, along with simply being a display to the Arduino. Please refer to the “[4DGL-Programmers-Reference-Manual.pdf](#)” and “[GOLDELOX-4DGL-Internal-Functions.pdf](#)” documents for more information on the 4DGL programming language.

The ViSi environment enables a visual programming experience for the user to quickly create a display using drag-and-drop objects. The user can simply lay the objects on the display and generate 4DGL code automatically for those objects. The user then manipulates this code the 4DGL codespace to further configure based on the users application requirements. This environment allows the user to immediately see what the display will look like once programmed.

The Serial environment enables the display to turn into a slave serial display, allowing all development to be done in the Arduino IDE. Writing commands from the Arduino and sending them over the Serial port, will enable the user to draw primitives, text, play video, animations and much more. This is the most common environment used for Arduino users. Please refer to the “[Workshop-4-IDE-User-Manual.pdf](#)” documentation for further information on the commands available.

Note: 4Display-Shield-160 modules will start shipping with μ OLED-160-G2 instead of μ OLED-160-G1 modules without warning or notice. No operational differences exist with respect to this Arduino Shield.

3.5. Jumper Settings

On the 4Display-Shield there is a 2x3 way jumper header (JP1), used to enable or disable the RX, TX and RESET lines between the Arduino and the display module.

When the shunt is connected between the two relevant pins, the feature of that configuration point is enabled. When disconnected, the feature is disabled.

- **RESET** – when the two pins are joined with the shunt, RESET is connected between the display module and Digital Pin D7 of the Arduino.
- **RX** – when the two pins are joined with the shunt, RX0 is from the display module is connected to the Arduino TX pin
- **TX** – when the two pins are joined with the shunt, TX0 is from the display module is connected to the Arduino RX pin

Disconnection of these jumpers will be required when programming the display module or the Arduino, as they share the same serial bus for both communications and for their individual programming.

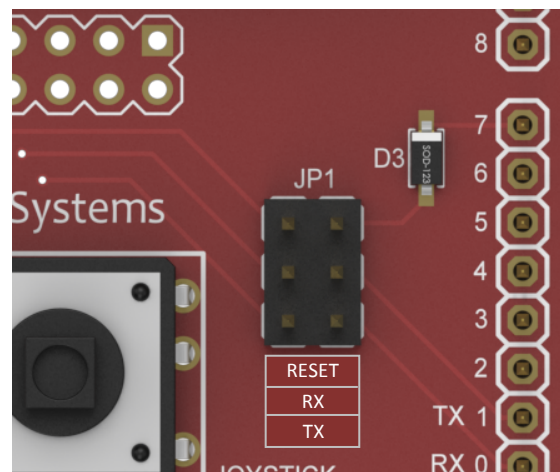

4. Related Products

μOLED-96-G2

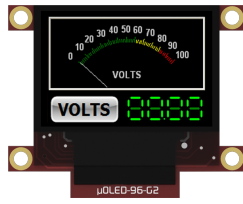

μOLED-128-G1

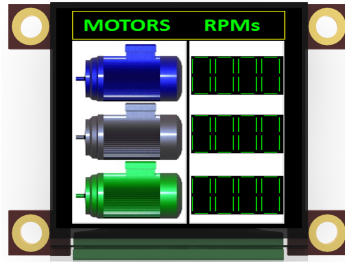

μOLED-128-G2



μOLED-160-G1



μOLED-160-G2

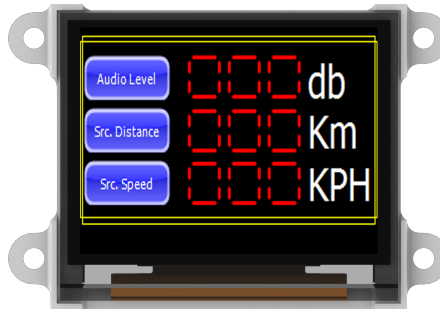

μLCD-144-G2



5. Schematic Design

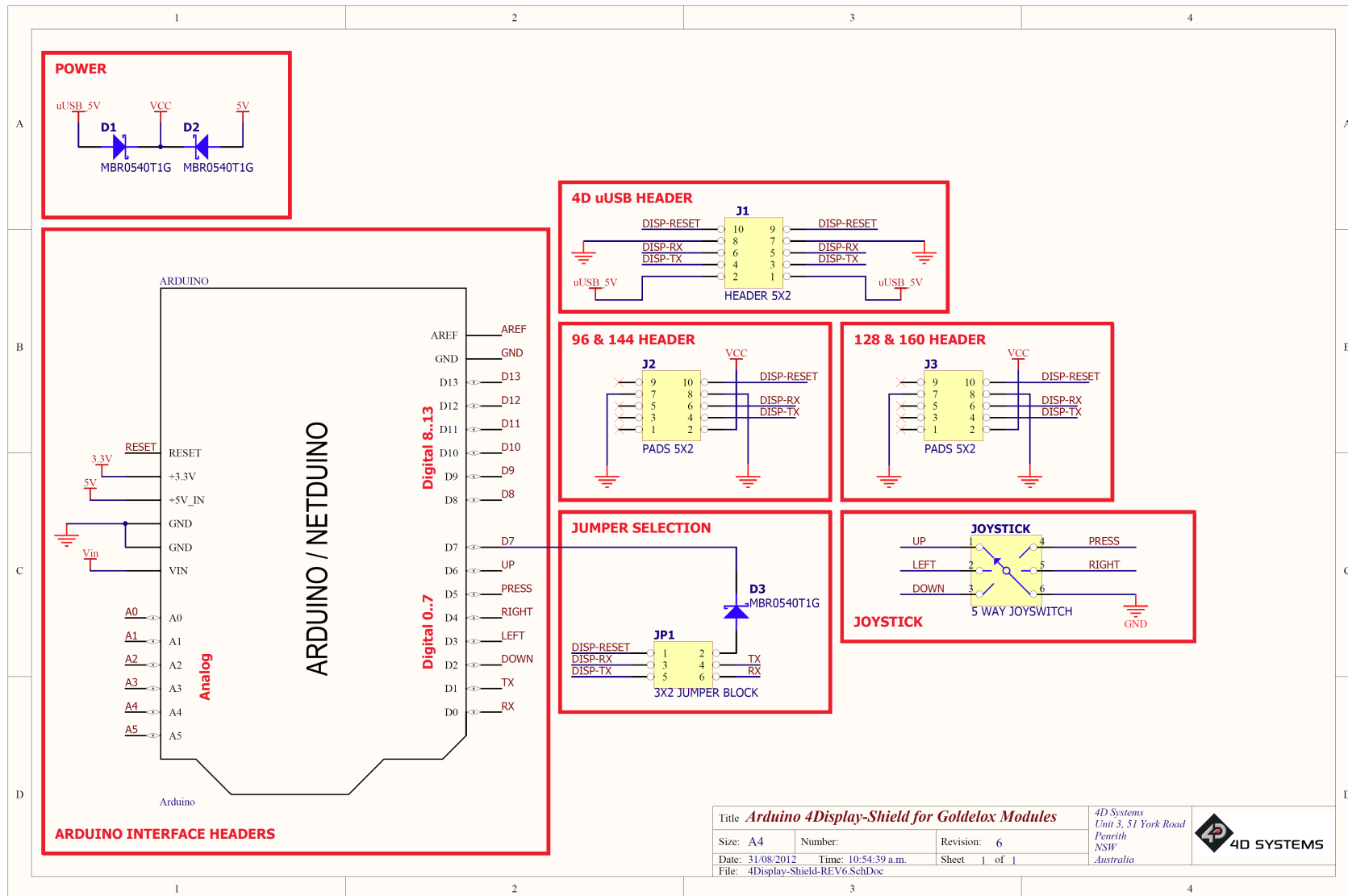

Title <i>Arduino 4Display-Shield for Golddex Modules</i>			4D Systems Unit 3, 51 York Road Penrith NSW Australia
Size: A4	Number:	Revision: 6	
Date: 31/08/2012	Time: 10:54:39 a.m.	Sheet 1 of 1	
File: 4Display-Shield-REV6.SchDoc			

6. Specifications and Ratings

RECOMMENDED OPERATING CONDITIONS					
Parameter	Conditions	Min	Typ	Max	Units
Supply Voltage (VCC)		4.5	--	5.5	V
Operating Temperature		-10	--	+65	°C
Input Low Voltage (VIL)	All pins	GND	--	0.8VCC	V
Input High Voltage (VIH)	All pins	2.0VCC	--	VCC	V
Reset Pulse (tRP)	External Open Collector	5.0	--	--	ms

For further specifications, specific to the actual display module, please refer to the 4D Systems website for further information, www.4dsystems.com.au

ORDERING INFORMATION
<p>Order Codes:</p> <ul style="list-style-type: none"> • 4Display-Shield-96 • 4Display-Shield-128 • 4Display-Shield-160 • 4Display-Shield-144 <p>Package: 105mm x 65mm x 30mm</p> <p>Packaging: Module sealed in antistatic foam padded 4D Systems Box</p>

7. Legal Notice

Proprietary Information

The information contained in this document is the property of 4D Systems Pty. Ltd. and may be the subject of patents pending or granted, and must not be copied or disclosed without prior written permission.

4D Systems endeavours to ensure that the information in this document is correct and fairly stated but does not accept liability for any error or omission. The development of 4D Systems products and services is continuous and published information may not be up to date. It is important to check the current position with 4D Systems. 4D Systems reserves the right to modify, update or make changes to Specifications or written material without prior notice at any time.

All trademarks belong to their respective owners and are recognised and acknowledged.

Disclaimer of Warranties & Limitation of Liability

4D Systems makes no warranty, either expressed or implied with respect to any product, and specifically disclaims all other warranties, including, without limitation, warranties for merchantability, non-infringement and fitness for any particular purpose.

Information contained in this publication regarding device applications and the like is provided only for your convenience and may be superseded by updates. It is your responsibility to ensure that your application meets with your specifications.

In no event shall 4D Systems be liable to the buyer or to any third party for any indirect, incidental, special, consequential, punitive or exemplary damages (including without limitation lost profits, lost savings, or loss of business opportunity) arising out of or relating to any product or service provided or to be provided by 4D Systems, or the use or inability to use the same, even if 4D Systems has been advised of the possibility of such damages.

4D Systems products are not fault tolerant nor designed, manufactured or intended for use or resale as on line control equipment in hazardous environments requiring fail – safe performance, such as in the operation of nuclear facilities, aircraft navigation or communication systems, air traffic control, direct life support machines or weapons systems in which the failure of the product could lead directly to death, personal injury or severe physical or environmental damage ('High Risk Activities'). 4D Systems and its suppliers specifically disclaim any expressed or implied warranty of fitness for High Risk Activities.

Use of 4D Systems' products and devices in 'High Risk Activities' and in any other application is entirely at the buyer's risk, and the buyer agrees to defend, indemnify and hold harmless 4D Systems from any and all damages, claims, suits, or expenses resulting from such use. No licenses are conveyed, implicitly or otherwise, under any 4D Systems intellectual property rights.

8. Contact Information

For Technical Support: support@4dsystems.com.au

For Sales Support: sales@4dsystems.com.au

Website: www.4dsystems.com.au

Copyright 4D Systems Pty. Ltd. 2000-2012.