

# DIGITRON SEMICONDUCTORS

1N2970-1N3015B AND 1N3993 THRU 1N4000A

10 WATT ZENER DIODES

## MAXIMUM RATINGS

JUNCTION TEMPERATURES	-65°C TO +175°C
STORAGE TEMPERATURES	-65°C TO +200°C
DC POWER DISSIPATION	10 WATTS
POWER DERATING	80 mW/°C ABOVE 50°C
FORWARD VOLTAGE	@ 2.0 A: 1.5 VOLTS
THERMAL RESISTANCE	10°C/W (TYPICAL) JUNCTION TO CASE (STUD)
SOLDER TEMPERATURES	260°C FOR 10 S (MAX)

## ELECTRICAL CHARACTERISTICS

TYPE NO. (note 1)	NOMINAL ZENER VOLTAGE $V_Z @ I_{ZT}$ (note 2)	ZENER TEST CURRENT ( $I_{ZT}$ )	MAX DYNAMIC IMPEDANCE (note 3)		MAX DC ZENER CURRENT ( $I_{ZM}$ ) @ 75°C STUD TEMP (note 4)	TYPICAL TEMP COEFF $\alpha_{VZ}$	MAX. REVERSE CURRENT $I_R @ V_R$		POLARITY
	VOLTS	mA	$Z_{ZT} @ I_{ZT}$ OHMS	$Z_{ZK} @ 1mA$ ( $I_{ZK}$ ) OHMS	mA	%/°C	µA	VOLTS	
1N3993A	3.9	640	2.0	400	2380	-.046	100	0.5	Standard polarity cathode to stud
1N3994A	4.3	580	1.5	400	2130	-.033	100	0.5	
1N3995A	4.7	530	1.2	500	1940	-.015	50	1.0	
1N3996A	5.1	490	1.1	550	1780	+/- .010	10	1.0	
1N3997A	5.6	445	1.0	600	1620	+.030	10	1.0	
1N3998A	6.2	405	1.1	750	1460	+.049	10	2.0	
1N3999A	6.8	370	1.2	500	1330	+.040	10	2.0	
1N4000A	7.5	335	1.3	250	1210	+.045	10	3.0	
1N2970B	6.8	370	1.2	500	1320	.040	150	5.2	
1N2971B	7.5	335	1.3	250	1180	.045	100	5.7	
1N2972B	8.2	305	1.5	250	1040	.048	50	6.2	
1N2973B	9.1	275	2.0	250	960	.051	25	6.9	
1N2974B	10	250	3	250	860	.055	25	7.6	
1N2975B	11	230	3	250	780	.060	10	8.4	
1N2976B	12	210	3	250	720	.065	10	9.1	
1N2977B	13	190	3	250	660	.065	10	9.9	
1N2978B	14	180	3	250	600	.070	10	10.5	
1N2979B	15	170	3	250	560	.070	10	11.4	
1N2980B	16	155	4	250	530	.070	10	12.2	
1N2981B	17	145	4	250	500	.075	10	13.0	
1N2982B	18	140	4	250	460	.075	10	13.7	
1N2983B	19	130	4	250	440	.075	10	14.0	
1N2984B	20	125	4	250	420	.075	10	15.2	
1N2985B	22	115	5	250	380	.080	10	16.7	
1N2986B	24	105	5	250	350	.080	10	18.2	
1N2987B	25	100	6	250	310	.080	10	18.2	
1N2988B	27	95	7	250	300	.085	10	20.6	
1N2989B	30	85	8	300	280	.085	10	22.8	
1N2990B	33	75	9	300	260	.085	10	25.1	

# DIGITRON SEMICONDUCTORS

1N2970-1N3015B AND 1N3993 THRU 1N4000A

10 WATT ZENER DIODES

1N2991B	36	70	10	300	230	.085	10	27.4	Standard polarity anode to stud
1N2992B	39	65	11	300	210	.090	10	29.7	
1N2993B	43	60	12	400	195	.090	10	32.7	
1N2994B	45	55	13	400	185	.090	10	33.0	
1N2995B	47	55	14	400	175	.090	10	35.8	
1N2996B	50	50	15	500	165	.090	10	36.0	
1N2997B	51	50	15	500	160	.090	10	38.8	
1N2998B	52	50	15	500	160	.090	10	39.0	
1N3099B	56	45	16	500	150	.090	10	42.6	
1N3000B	62	40	17	600	130	.090	10	47.1	
1N3001B	68	37	18	600	120	.090	10	51.7	
1N3002B	75	33	22	600	110	.090	10	56.0	
1N3003B	82	30	25	700	100	.090	10	62.2	
1N3004B	91	28	35	800	85	.090	10	69.2	
1N3005B	100	25	40	900	80	.090	10	76.0	
1N3006B	105	25	45	1000	75	.095	10	76.0	
1N3007B	110	23	55	1100	72	.095	10	83.6	
1N3008B	120	20	75	1200	67	.095	10	91.2	
1N3009B	130	19	100	1300	62	.095	10	98.8	
1N3010B	140	18	125	1400	58	.095	10	100.0	
1N3011B	150	17	175	1500	54	.095	10	114.0	
1N3012B	160	16	200	1600	50	.095	10	121.6	
1N3013B	175	14	250	1750	46	.095	10	135.0	
1N3014B	180	14	260	1850	45	.095	10	136.8	
1N3015B	200	12	300	2000	40	.100	10	152.0	

Note 1: 1N3993-1N4000 series: suffix A indicates +/-5% tolerance, no suffix indicates +/-10% tolerance.

1N2970-1N3015 series: suffix B indicates +/-5% tolerance, suffix A indicates +/-10% no suffix indicates +/-20% tolerance.

Note 2: The electrical characteristics are measured after allowing the device to stabilize for 90 seconds with 30°C base temperature

Note 3: The Zener impedance ( $Z_{ZT}$ ) is derived from the 60 Hz ac voltage, which results when an ac current having an rms value equal to 10% of the dc zener current ( $I_{ZT}$  or  $I_{ZK}$ ) is superimposed on  $I_{ZT}$  or  $I_{ZK}$ . When making Zener impedance measurements at the  $I_{ZK}$  test point, it may be necessary to insert a 60 Hz band pass filter between the diode and the voltmeter to avoid errors resulting from low level noise signals.

Note 4: These values of  $I_{ZM}$  may be exceeded in the case of the individual diodes. The values shown are calculated for the worst case that is a unit of +/- 5% tolerance at the high voltage end of its tolerance range. Allowance has also been made for the rise in Zener voltage above  $V_{ZT}$ , which results from Zener impedance and the increase in junction temperature as power dissipation approaches 10 watts.

## MECHANICAL CHARACTERISTICS

<b>Case</b>	DO-4, 7/16" hex, stud with 10-32 threads, welded, hermetically sealed metal with glass
<b>Polarity</b>	1N3993-1N4000 : standard polarity is cathode to stud. Reverse polarity (anode to stud) indicated by suffix "R". 1N2970-1N3015: Standard polarity is anode to stud. Reverse polarity indicated by suffix "R".

Available Non-RoHS (standard) or RoHS compliant (add PBF suffix).

Available as "HR" (high reliability) screened per MIL-PRF-19500, JANTX level. Add "HR" suffix to base part number.

# DIGITRON SEMICONDUCTORS

1N2970-1N3015B AND 1N3993 THRU 1N4000A

10 WATT ZENER DIODES

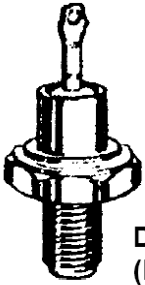

**DO-4  
(DO-203AA)**

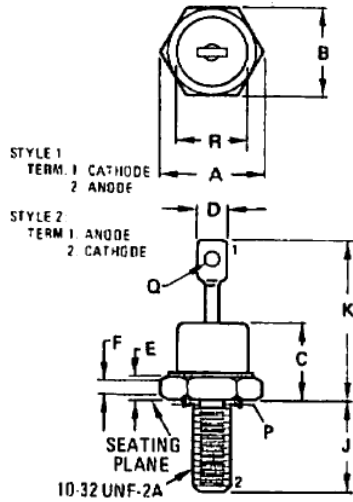

Dim	Inches		Millimeters	
	Min	Max	Min	Max
A	0.470	0.505	11.940	12.830
B	0.424	0.437	10.770	11.100
C	-	0.405	-	10.290
D	-	0.250	-	6.350
E	0.075	0.175	1.910	4.450
F	0.060	-	1.520	-
J	0.422	0.453	10.720	11.510
K	-	0.800	-	20.320
P	0.163	0.189	4.140	4.800
Q	0.060	-	1.520	-
R	-	0.424	-	10.77

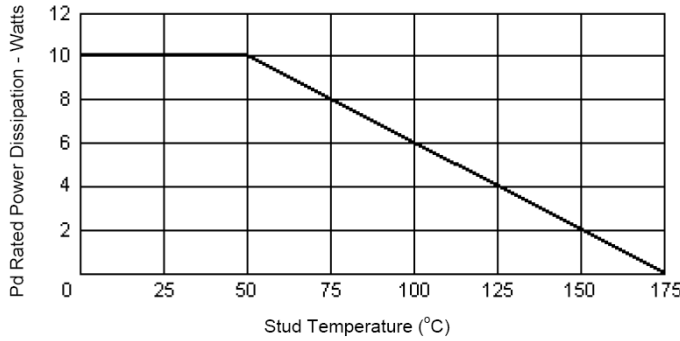

**FIGURE 1**  
Power Derating Curve

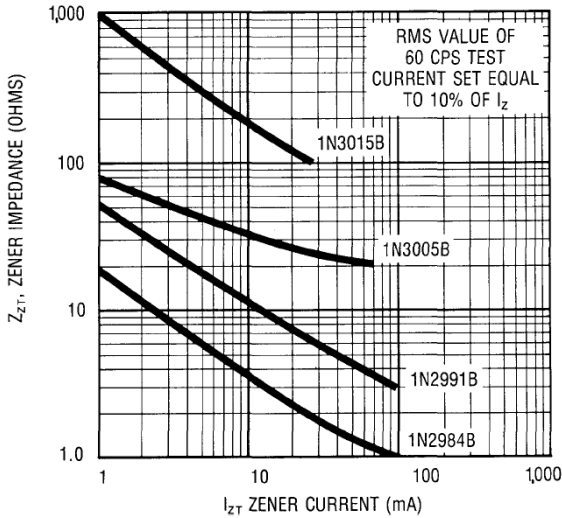

**FIGURE 2**  
Typical Zener Impedance vs. Zener Current  
For Types Shown

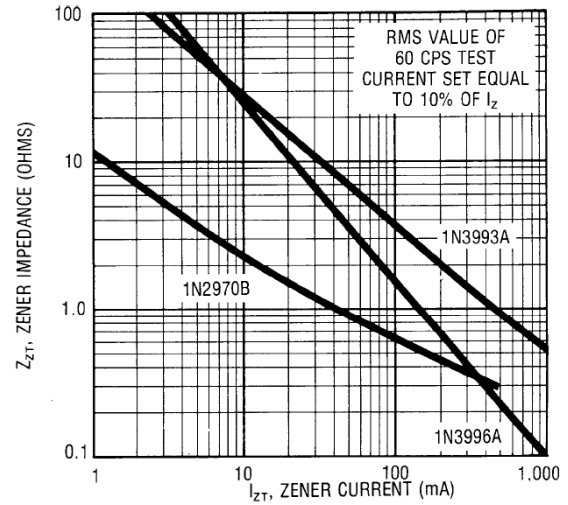

**FIGURE 3**  
Typical Zener Impedance vs. Zener Current  
For Types Shown