

Wire-wound Type Power Inductor

SCWL201610 Series

Features

- u Low profile: 2.0mm×1.6mm×1.0mm
- u Magnetically shielded structure to accomplish high resolution in EMC protection
- u Halogen free, Lead free, RoHS compliance

Applications

SCWL series is generic applied in portable DC to DC converter line.

- u Mobile phones
- u HDDs
- u DSCs
- u PADs
- u LCD, LED display, etc.

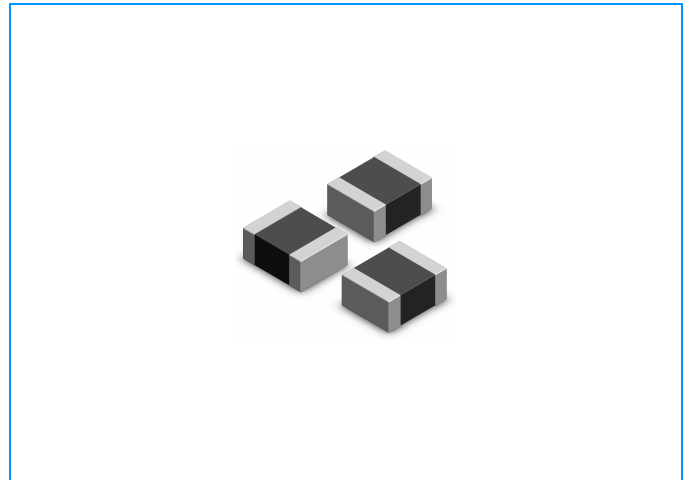

General Technical Data

Operating Temperature Range		-40 ~ +125°C
Storage Temperature Range		-50 ~ +125°C
Taping package Storage condition	Storage Temperature	5 ~ 40°C
	Relative Humidity	< 65%
	Storage Time	12 Months max

Part Numbering

SCWL 2016 10 R47 M T F
 (1) (2) (3) (4) (5) (6) (7)

- 1 Series Name, wire-wound type power inductor
- 2 Size Code: the first two digitals : length(mm), the last two digitals : width(mm)
- 3 Thickness (mm)
- 4 Inductance (μH), eg. 2R2=2.2μH; R47=0.47μH
- 5 Inductance tolerance, M: ±20%
- 6 Packaging: T - Embossed plastic tape, 7" reel.
- 7 Soldering : Green Parts, F - Lead-Free for whole chip

Wire-wound Type Power Inductor

SCWL201610 Series

Electrical Characteristics

Part Number	Initial Inductance Li (μH) @1mA	DC Resistance R _{DC} (mΩ)		Saturation Current Isat (A)		Heat Rating Current I _{rms} (A)	
		Typical	Maximum	Typical	Maximum	Typical	Maximum
SCWL201610R24MTF	0.24	16	19	6.5	5.7	4.1	3.6
SCWL201610R47MTF	0.47	34	40	4.2	3.8	2.8	2.5
SCWL201610R68MTF	0.68	39	47	3.8	3.3	2.5	2.2
SCWL2016101R0MTF	1.0	60	72	3.2	2.8	2.1	1.9
SCWL2016102R2MTF	2.2	150	172	2.2	2.0	1.5	1.3

Note:

- All test data is referenced to 25 °C ambient.
- Inductance is measured by LCR meter, Test frequency at 1MHz
- Inductance Tolerance: ±20%.
- Isat: DC current that will cause L0 to drop approximately 30% at ambient 25 °C.
- I_{dc}: DC current that will cause an approximate ΔT of 40 °C.
- Rating Current: Value as listed is either the saturation current or the heating current, whichever is smaller.
- The part temperature (Ambient + temp rise) should not exceed 125 °C under worst case operating condition.

Current Characteristics

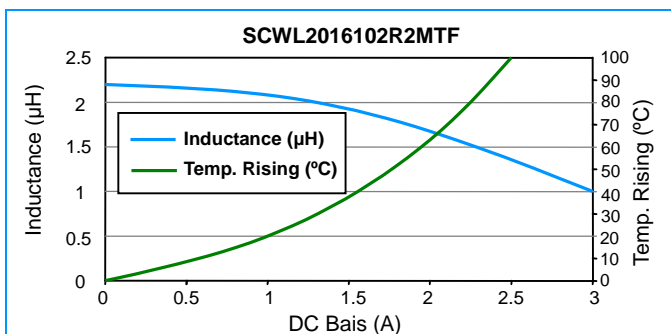
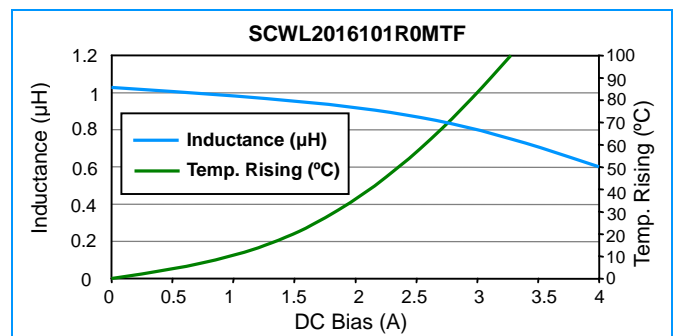
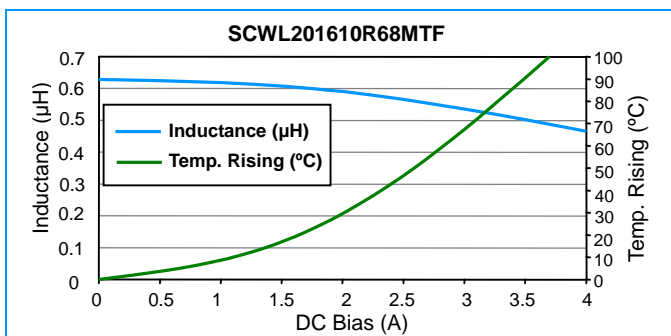
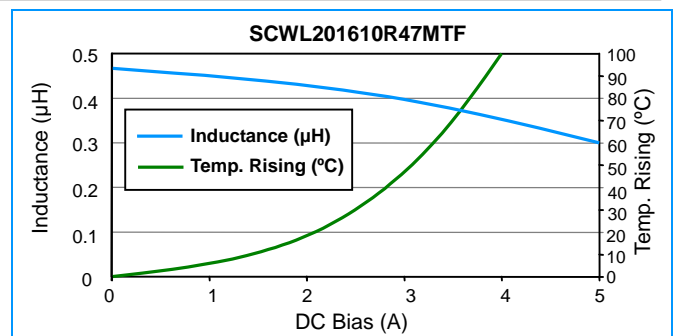
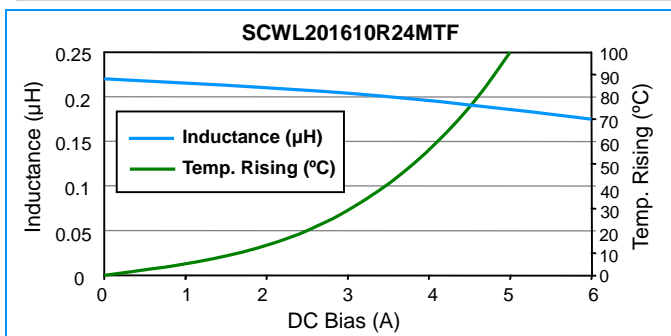

Wire-wound Type Power Inductor

SCWL201610 Series

Tape Specifications

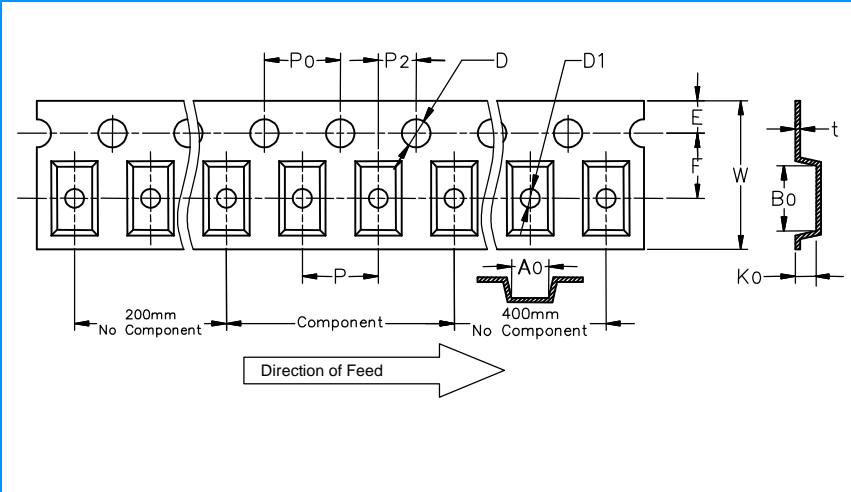

Symbol	252010
W	8.00±0.3
P	4.00±0.10
E	1.75±0.10
F	3.50±0.05
D	1.55±0.05
P	4.00±0.10
P0	4.00±0.10
P2	2.00±0.05
A0	1.80±0.10
B0	2.20±0.10
K0	1.15±0.10
t	0.22±0.05

Reel Specifications & Packaging

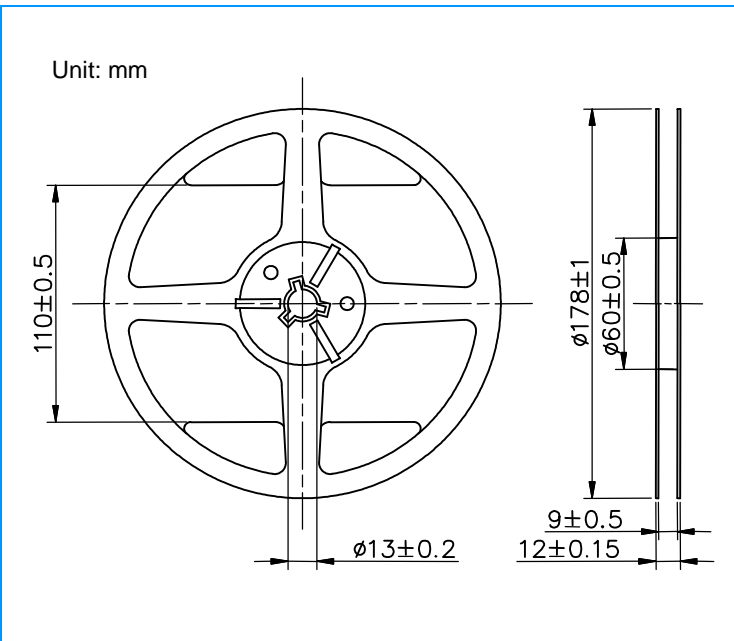

Part Size (EIA Size)	Packaging Option	Quantity
2016	7"Reel	3,000

The Contents of a box:
2016: 6 reels / inner box

Wire-wound Type Power Inductor

SCWL201610 Series

Soldering Parameters

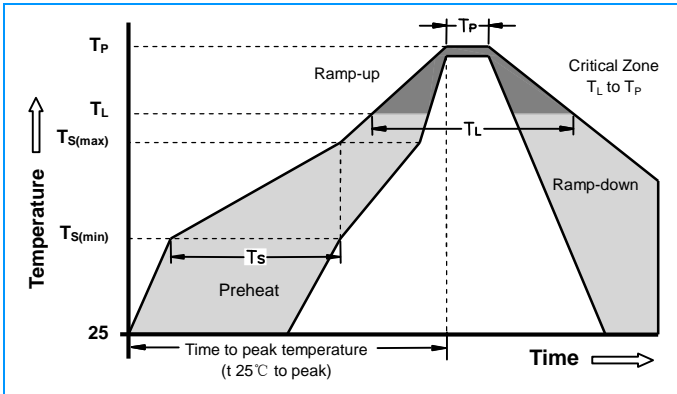

Precaution for Soldering

Note that this product will be easily damaged by rapid heating, rapid cooling or local heating.

Do not give heat shock over 100°C in the process of soldering. We recommend to take preheating and gradual cooling

Soldering gun procedure

Note the follows, in case of using solder gun for replacement.

- 1) The tip temperature must be less than 280 for the period within 3 seconds by using soldering gun under 30W
- 2) The soldering gun tip shall not touch this product directly.

Soldering volume

Note that excess of soldering volume will easily get crack the body of this product.

Precaution for Handling of Substrate

Do not exceed to bend the board after soldering this product extremely. (reference examples)

- I Mounting place must be as far as possible from the position, which is close to the break line of board, or on the line of large holes of board.
- I Do not bend extremely the board, in mounting another component. If necessary, use back-up pin (support pin) to prevent from bending extremely.
- I Do not break the board by hand. We recommend to use the machine or the jig to break it.

Recommended Pad Layout

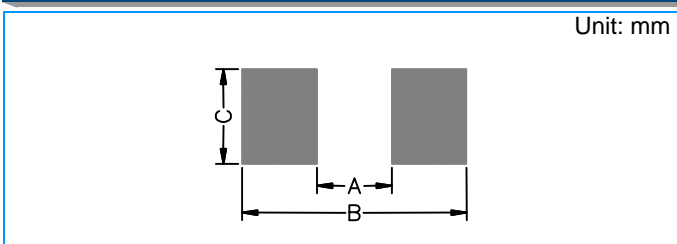

Reflow Condition		Pb free assembly
Pre Heat	-Temperature Min ($T_{s(min)}$)	+150°C
	-Temperature Max ($T_{s(max)}$)	+200°C
	-Time (min to max) (T_s)	60 - 180 Seconds
Average ramp up rate (Liquidus Temp T_L to peak)		3°C/Second Max
$T_{s(max)}$ to T_L - Ramp-up Rate		3°C/Second Max
Reflow	- Temperature (T_L) (Liquidus)	+217°C
	- Time (min to max) (T_L)	60 - 150 Seconds
Peak Temperature (T_P)		260 +0/-5°C
Time within 5°C of actual peak Temperature (T_P)		20-40 Seconds
Ramp-down Rate		6°C/Second Max
Time 25°C to peak Temperature (T_P)		8 minutes Max

Construction & Dimensions

Core Material: Iron

End termination: Ni / Sn

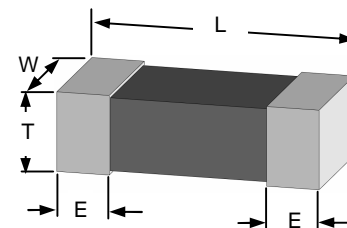

Unit: mm

L	W	T	E
2.0±0.2	1.6±0.2	1.0 Max	0.5±0.3

A	B	C
0.9	2.0	1.6

Wire-wound Type Power Inductor

SCWL201610 Series

Reliability and Test Condition

Test Item	Test Condition	Criteria
Resistance to Solder Heat	<ol style="list-style-type: none"> Solder temperature : 260±5℃ Flux : Rosin DIP time : 10±1 sec 	<ol style="list-style-type: none"> More than 95 % of terminal electrode should be covered with new solder No mechanical damage Induction value should be within ±20 % of the initial value
Adhesive Test	<ol style="list-style-type: none"> Reflow temperature : 245℃ It shall be Soldered on the substrate applying direction parallel to the substrate Apply force(F) : 5 N Test time : 10 sec 	<ol style="list-style-type: none"> No mechanical damage Soldering the products on PCB after the pulling test force > 5 N
Temperature Cycle	<ol style="list-style-type: none"> Temperature : -50 ~ +125℃ for 30 minutes each Cycle : 500 cycles Measurement : At ambient temperature 24 hours after test completion 	<ol style="list-style-type: none"> No mechanical damage Induction value should be within ±20 % of the initial value
Dry Heat Test	<ol style="list-style-type: none"> Temperature : 85℃±5℃ Test time : 500 hours Apply current : full rated current Measurement : At ambient temperature 24 hours after test completion 	<ol style="list-style-type: none"> No mechanical damage Induction value should be within ±20 % of the initial value
Humidity Test	<ol style="list-style-type: none"> Temperature : 60℃±2℃ Humidity : 90 ~ 95 % RH Apply current : full rated current Test time : 500 hours Measurement : At ambient temperature 24 hours after test completion 	<ol style="list-style-type: none"> No mechanical damage Induction value should be within ±20 % of the initial value