

LOC	DIST	REVISIONS					
AF	50	P	LTR	DESCRIPTION	DATE	DWN	APVD
		G		REV PER ECR-07-025738	30JAN08	JR	JK

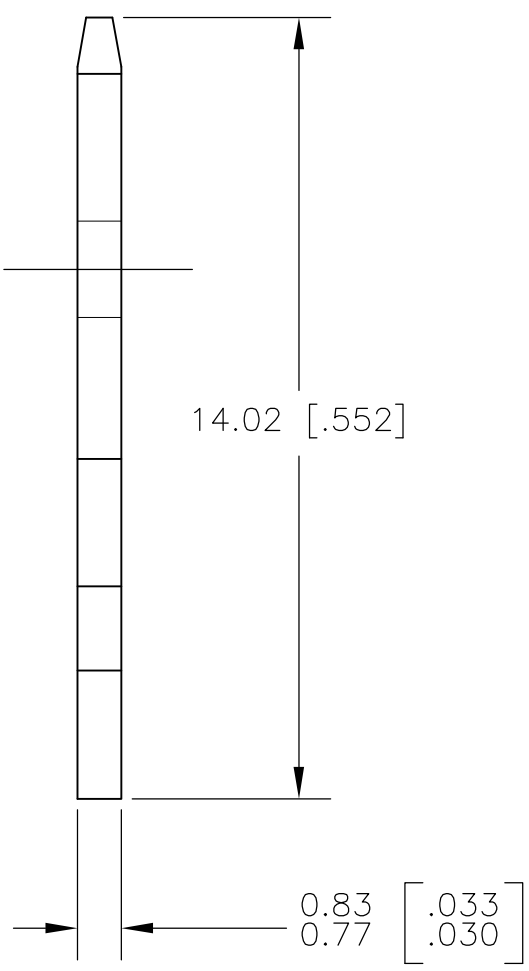

- 1 CONTINUOUS STRIP ON REELS.
- 2 TIN PLATE 0.00381 [.000150] MIN OVER 0.00254 [.000100] MIN THK COPPER OR TIN PLATE 0.00381 [.000150] MIN OVER 0.00127 [.000050] MIN THK NICKEL.
- 3 FEED IS 7.92±0.076 [.312±.003]
- 4 OPTIONAL ID MARK, LOCATED APPROX AS SHOWN.

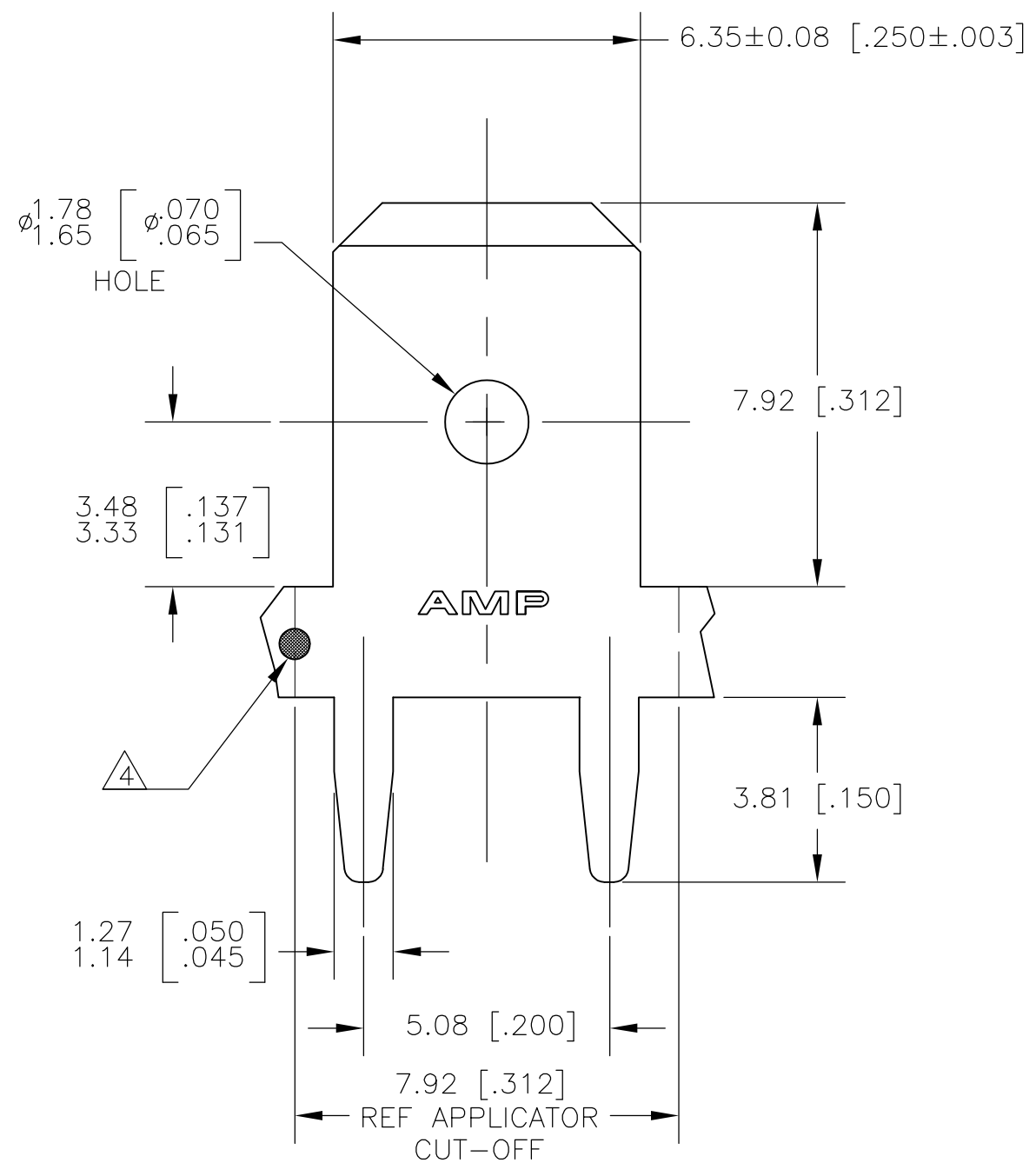
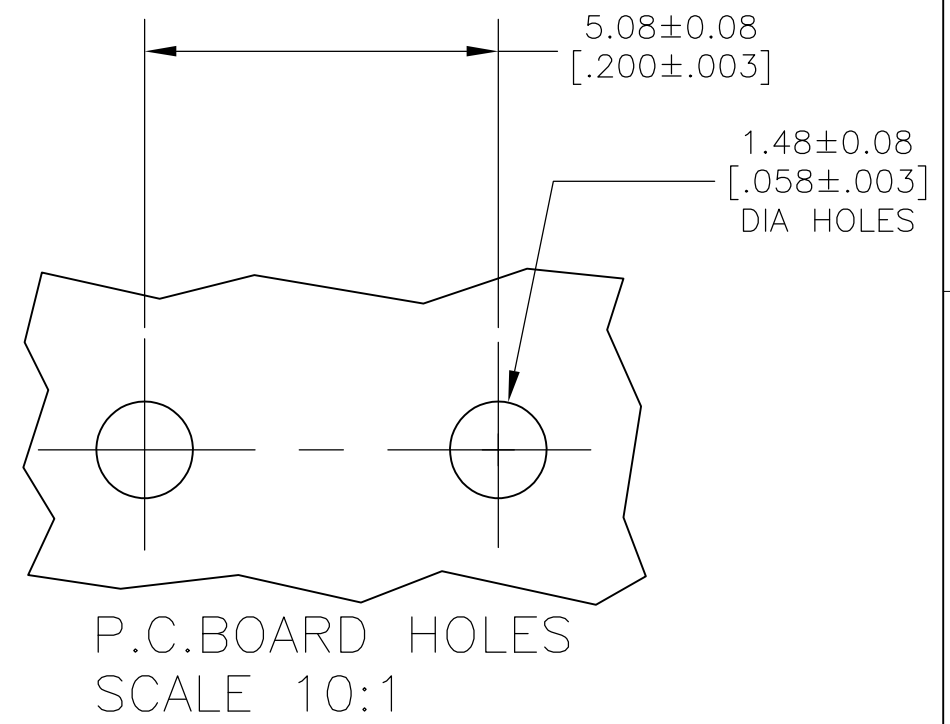

REVERSE REELED	1217566-2
STANDARD	1217566-1
REELING	PART NUMBER

THIS DRAWING IS A CONTROLLED DOCUMENT.		DWN	JR RUTH	11JAN01	Tyco Electronics Corporation Harrisburg, PA 17105-3608										
DIMENSIONS: mm [INCHES]		CHK	MS FEHER	11JAN01											
TOLERANCES UNLESS OTHERWISE SPECIFIED:		APVD	N DEIBERT	11JAN01	NAME TAB, FASTON, PC BOARD, 6.35 [.250] SERIES										
0 PLC ± - 1 PLC ± - 2 PLC ± 0.25 [.010] 3 PLC ± - 4 PLC ± - ANGLES ± -		PRODUCT SPEC	-												
MATERIAL	082 BRASS	FINISH	TIN OVER COPPER	APPLICATION SPEC	114-2115	SIZE	A3	CAGE CODE	00779	DRAWING NO	C-1217566	RESTRICTED TO	-		
CUSTOMER DRAWING										SCALE	8:1	SHEET	1 OF 1	REV	G