

**DESIGNED & DIMENSIONED
IN MILLIMETERS(INCHES)**

UUSB3-AB-S-X-XX-TR

VERSION
-3.0

TYPE
-MICRO AB

CONFIGURATION
-S: SINGLE

OPTION
-TR: TAPE AND REEL

TERMINATION
-SM: SHIELD TAB, SURFACE MOUNT CONTACT, SURFACE MOUNT
*-MT: SHIELD TAB, THROUGH HOLE CONTACT, SURFACE MOUNT

PLATING SPECIFICATION
-S: .000030" MIN GOLD ON MATING AREA
.000003" MIN GOLD ON SOLDER TAIL WITH .000050" MIN NICKEL UNDERPLATE
-F: .000003" MIN GOLD FLASH ON THE WHOLE CONTACT WITH .000050" MIN NICKEL UNDERPLATE
SHIELD PLATED:
0.000050" NICKEL WITH 0.000050" COPPER UNDERPLATED
* = NOT TOOLED

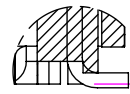
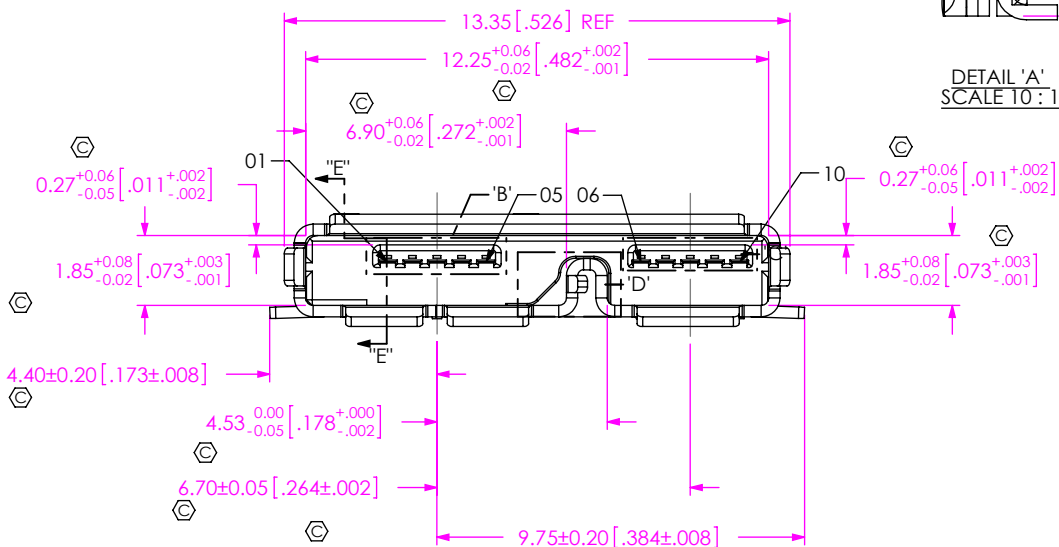
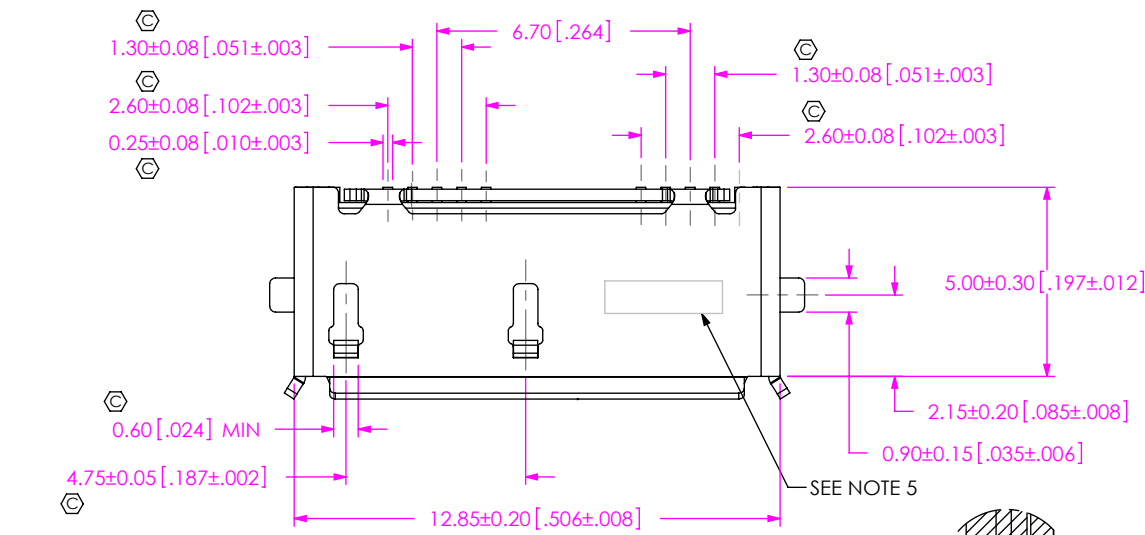

DETAIL 'A'
SCALE 10:1

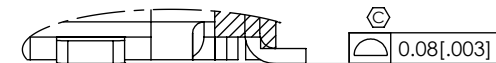
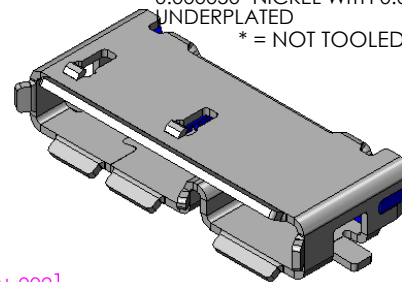

DETAIL 'F'
SCALE 10:1

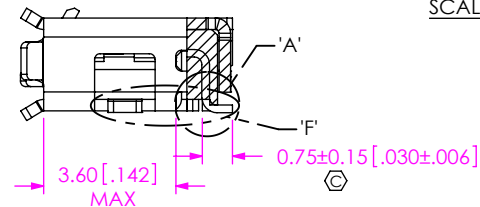

NOTES:

1. Ⓢ REPRESENTS A CRITICAL DIMENSION.
2. VENDOR: YANGMING PRECISION OF PLASTIC METAL ELECTRONIC CO.; PART NUMBER: 11163-210001-00.
3. PART TO BE COMPLIANT WITH USB3.0 SPECIFICATION.
4. THE COMPONENTS BE ROHS COMPLIANT, RECEPTACLE MATERIALS SHOULD CONFORM TO DIRECTIVE 2002/95/EC OF JANUARY 27, 2003 ON ROHS OR OTHER REGULATORY DIRECTIVES.
5. TAPE REEL PACKAGE OFFERED BY SUPPLIER.
6. INK PRINTED SAMTEC LOGO AND DATE CODE:

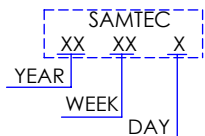

7. IF CUSTOMERS PURCHASE LESS THAN A FULL REEL THEY WILL NOT GET A LEADER AND TRAILER AND THESE WILL BE SHIPPED IN A BOX, BUT IN POCKETS.

UNLESS OTHERWISE SPECIFIED,
DIMENSIONS ARE
IN MILLIMETERS(INCHES).
TOLERANCES ARE:
DECIMALS ANGLES
X.X: ±0.3 [.01] 2°
X.XX: ±0.13 [.005]
X.XXX: ±0.051 [.0020]

PROPRIETARY NOTE

THIS DOCUMENT CONTAINS INFORMATION CONFIDENTIAL AND PROPRIETARY TO SAMTEC, INC. AND SHALL NOT BE REPRODUCED OR TRANSFERRED TO OTHER DOCUMENTS OR DISCLOSED TO OTHERS OR USED FOR ANY PURPOSE OTHER THAN THAT WHICH IT WAS OBTAINED WITHOUT THE EXPRESSED WRITTEN CONSENT OF SAMTEC, INC.

MATERIAL: DO NOT SCALE DRAWING
HOUSING: LCP E-130I BLACK
CONTACT: PHOSPHOR BRONZE C5191-H
SHIELD: SUS304-1/2H

SHEET SCALE: 5:1



520 PARK EAST BLVD, NEW ALBANY, IN 47150
PHONE: 812-944-6733 FAX: 812-948-5047
e-Mail: info@SAMTEC.com code: 55322

DESCRIPTION:
MICRO USB 3.0 A TYPE RECEPTACLE

DWG. NO.
UUSB3-AB-S-X-XX-TR

BY: TIM CHU 5/25/2010 SHEET 1 OF 3

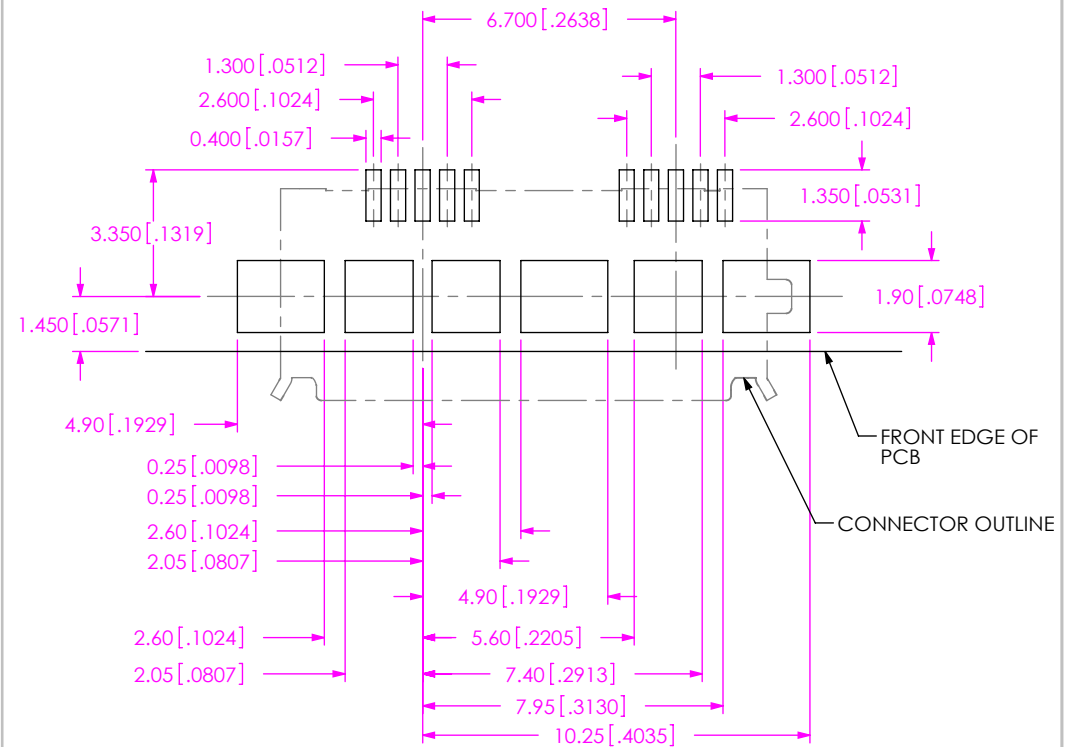
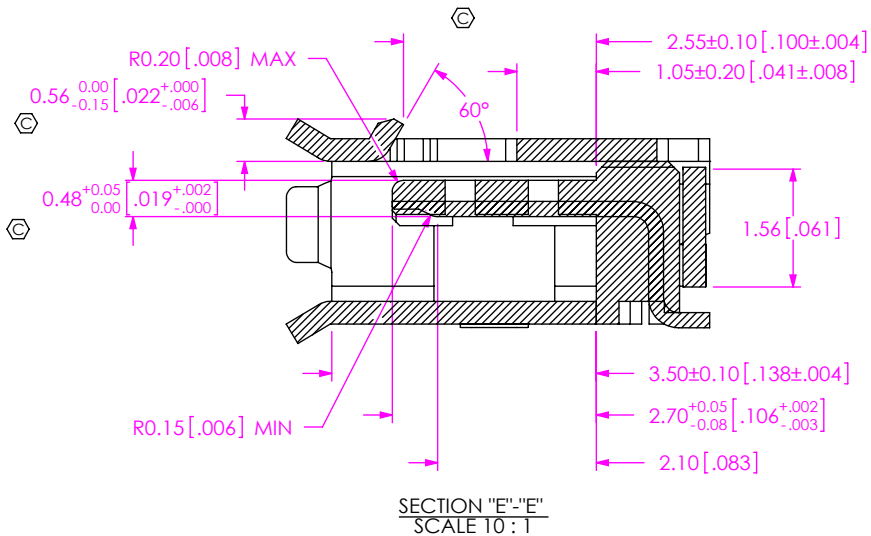
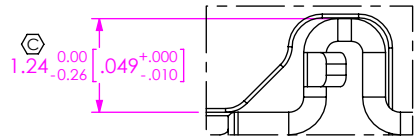
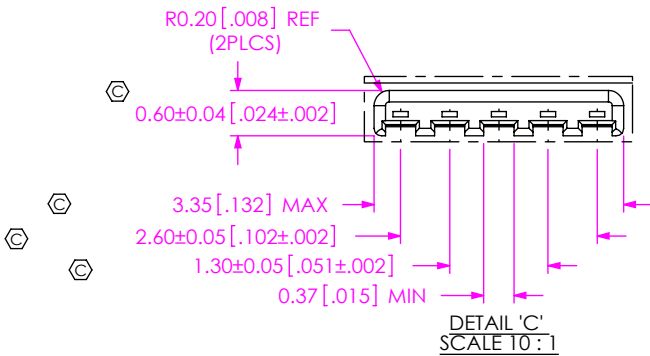
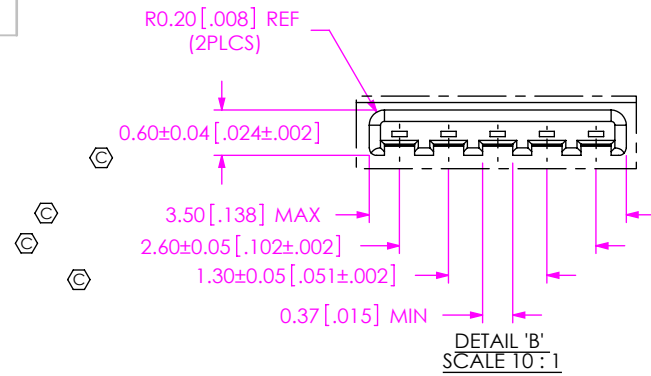

RECOMMENDED PCB LAYOUT

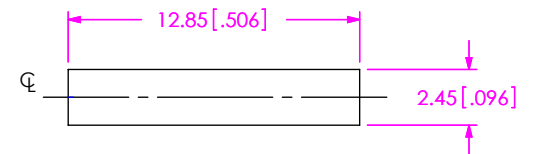

SUGGESTED PANEL CUTOUT DIMENSIONS

PROPRIETARY NOTE
THIS DOCUMENT CONTAINS INFORMATION
CONFIDENTIAL AND PROPRIETARY TO
SAMTEC, INC. AND SHALL NOT BE REPRODUCED
OR TRANSFERRED TO OTHER DOCUMENTS OR
DISCLOSED TO OTHERS OR USED FOR ANY
PURPOSE OTHER THAN THAT WHICH IT WAS
OBTAINED WITHOUT THE EXPRESSED WRITTEN
CONSENT OF SAMTEC, INC.

DO NOT SCALE DRAWING

SHEET SCALE: 1:0.333333

samtec

520 PARK EAST BLVD, NEW ALBANY, IN 47150
PHONE: 812-944-6733 FAX: 812-948-5047
e-Mail: info@SAMTEC.com code: 55322

DESCRIPTION: MICRO USB 3.0 A TYPE RECEPTACLE

DWG. NO. UUSB3-AB-S-X-XX-TR

BY: TIM CHU 5/25/2010 SHEET 2 OF 3

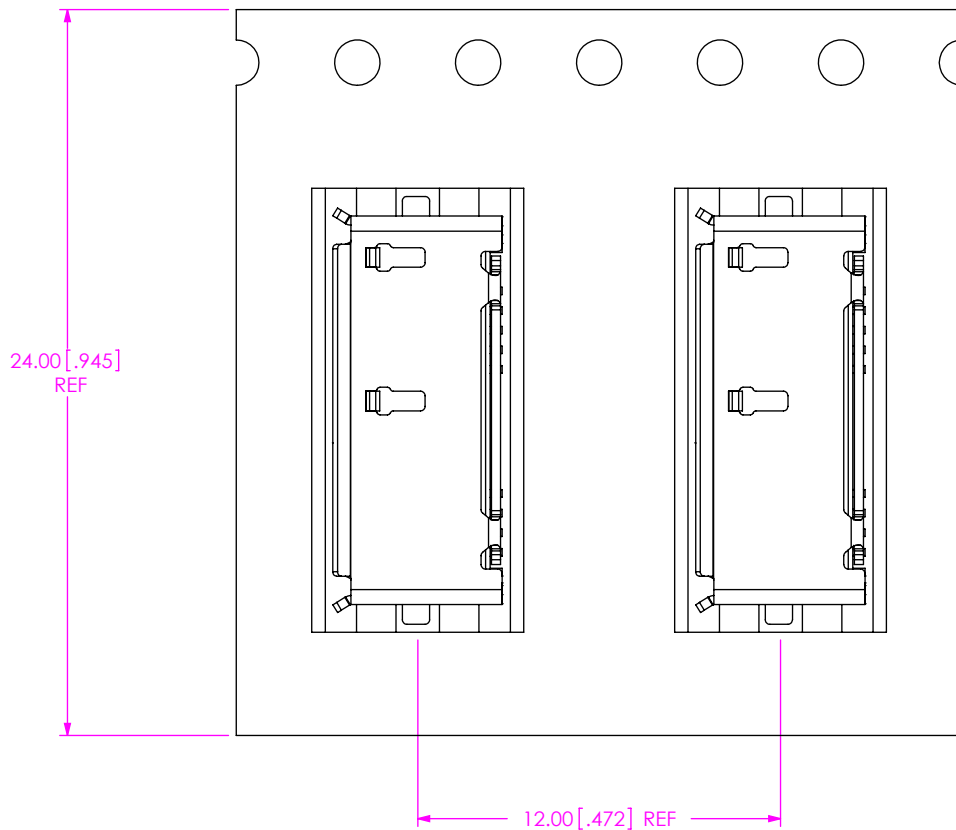

USER DIRECTION OF UN-REELING →
POCKET NOT DETAILED

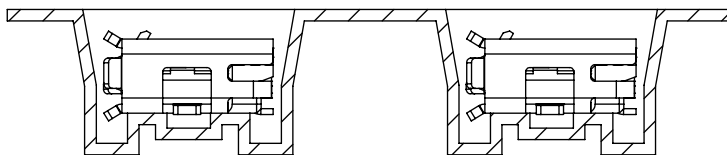

PACKAGING VIEW

PROPRIETARY NOTE
THIS DOCUMENT CONTAINS INFORMATION CONFIDENTIAL AND PROPRIETARY TO SAMTEC, INC. AND SHALL NOT BE REPRODUCED OR TRANSFERRED TO OTHER DOCUMENTS OR DISCLOSED TO OTHERS OR USED FOR ANY PURPOSE OTHER THAN THAT WHICH IT WAS OBTAINED WITHOUT THE EXPRESSED WRITTEN CONSENT OF SAMTEC, INC.

DO NOT SCALE DRAWING

SHEET SCALE: 2:1



520 PARK EAST BLVD, NEW ALBANY, IN 47150
PHONE: 812-944-6733 FAX: 812-948-5047
e-Mail: info@SAMTEC.com code: 55322

DESCRIPTION: MICRO USB 3.0 A TYPE RECEPTACLE

DWG. NO. UUSB3-AB-S-X-XX-TR

BY: TIM CHU 5/25/2010 SHEET 3 OF 3