



SPN6001

N-Channel Enhancement Mode MOSFET

DESCRIPTION

The SPN6001 is the N-Channel enhancement mode field effect transistors that are produced using high cell density DMOS technology.

APPLICATIONS

- High efficiency SMPS
- AC adapter
- Electronic Lamp Ballast

FEATURES

- ◆ 600V/1.0A , $R_{DS(ON)} = 15\Omega @ V_{GS} = 10V$
- ◆ TO-92 package design
- ◆ Fast switch, Low Ciss, Low gate charge
- ◆

PIN CONFIGURATION(TO-92)

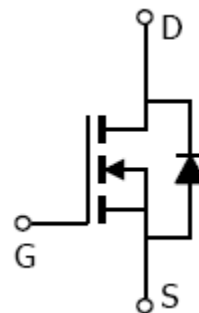
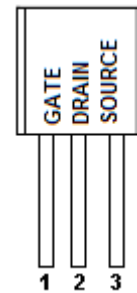

PART MARKING

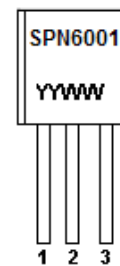

Y : Year Code
W : Week Code



SPN6001

N-Channel Enhancement Mode MOSFET

PIN DESCRIPTION

Pin	Symbol	Description
1	G	Gate
2	D	Drain
3	S	Source

ORDERING INFORMATION

Part Number	Package	Part Marking
SPN6001T92AGB	TO-92	SPN6001

※ Week Code : 01~53

※ SPN6001T92AGB : Tape Ammo ; Pb – Free ; Halogen - Free

ABSOLUTE MAXIMUM RATINGS (TA=25°C Unless otherwise noted)

Parameter	Symbol	Typical	Unit
Drain-Source Voltage	V _{DSS}	600	V
Gate –Source Voltage - Continuous	V _{GSS}	±20	V
Gate –Source Voltage - Non Repetitive (t _p < 50μs)	V _{GSS}	±40	V
Continuous Drain Current(T _J =150°C)	I _{DM}	1	A
TA=25°C			
Pulsed Drain Current (*)	I _{DM}	2.5	A
Power Dissipation	P _D	3	W
TA=25°C			
Operating Junction Temperature	T _J	-55 ~ 150	°C
Storage Temperature Range	T _{STG}	-55 ~ 150	°C
Thermal Resistance-Junction to Ambient	R _{θJA}	120	°C/W

(*) Pulse width limited by safe operating area



SPN6001

N-Channel Enhancement Mode MOSFET

ELECTRICAL CHARACTERISTICS ($T_A=25^{\circ}\text{C}$ Unless otherwise noted)

Parameter	Symbol	Conditions	Min.	Typ	Max.	Unit
Static						
Drain-Source Breakdown Voltage	$V_{(BR)DSS}$	$V_{GS}=0V, I_D=250\mu A$	600			V
Gate Threshold Voltage	$V_{GS(th)}$	$V_{DS}=V_{GS}, I_D=250\mu A$	2.0		4.0	
Gate Leakage Current	I_{GSS}	$V_{DS}=0V, V_{GS}=\pm 20V$			± 100	nA
Zero Gate Voltage Drain Current	I_{DSS}	$V_{DS}=480V, V_{GS}=0V$			10	μA
Drain-Source On-Resistance	$R_{DS(on)}$	$V_{GS}=10V, I_D=500mA$			15	Ω
Forward On Voltage	V_{SD}	$V_{GS}=0V, I_D=500mA$			1	V
Forward Transconductance	G_{fs}	$V_{DS} = 40 V, I_D = 500 mA$		0.8		S
Dynamic						
Total Gate Charge	Q_g	$V_{DD} = 480 V, I_D = 1 A,$ $V_{GS} = 10 V$		6.1	7.2	nC
Gate-Source Charge	Q_{gs}			1.0		
Gate-Drain Charge	Q_{gd}			3.0		
Input Capacitance	C_{iss}	$V_{DS} = 25 V, f = 1 MHz,$ $V_{GS} = 0$		178	221	pF
Output Capacitance	C_{oss}			19	27	
Reverse Transfer Capacitance	C_{rss}			3.7	4.8	
Turn-On Time	$t_{d(on)}$	$V_{DD} = 300 V, I_D = 1 A$ $R_G = 25\Omega$		15		ns
	t_r			46		
Turn-Off Time	$t_{d(off)}$			26		
	t_f			37		

(1) Pulsed: Pulse duration = 300 μs , duty cycle 2 %.

(2) Pulse width limited by maximum junction temperature.



SPN6001 N-Channel Enhancement Mode MOSFET

TYPICAL CHARACTERISTICS

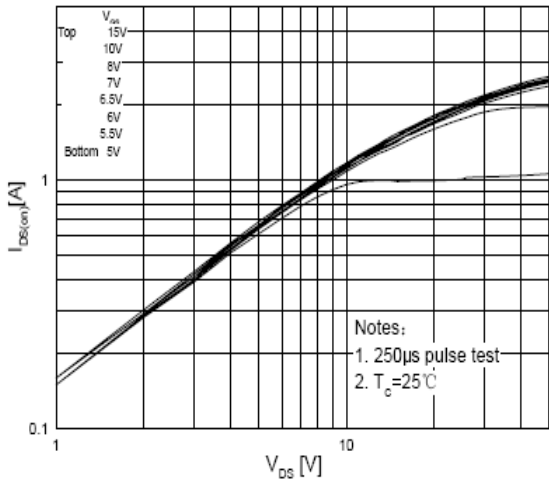

Fig. 1 Typical Output Characteristics

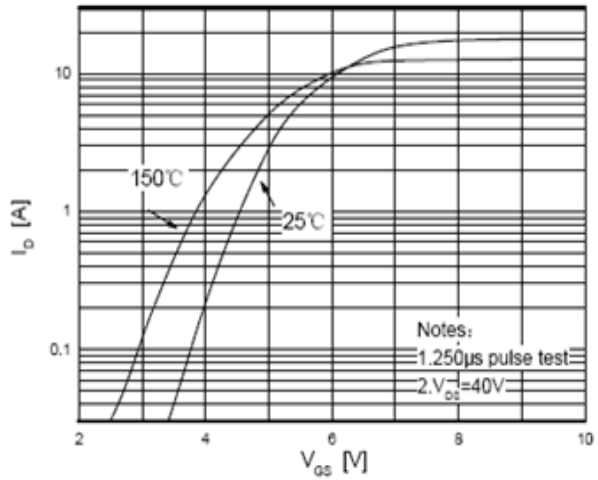

Fig. 2 Transfer Characteristics

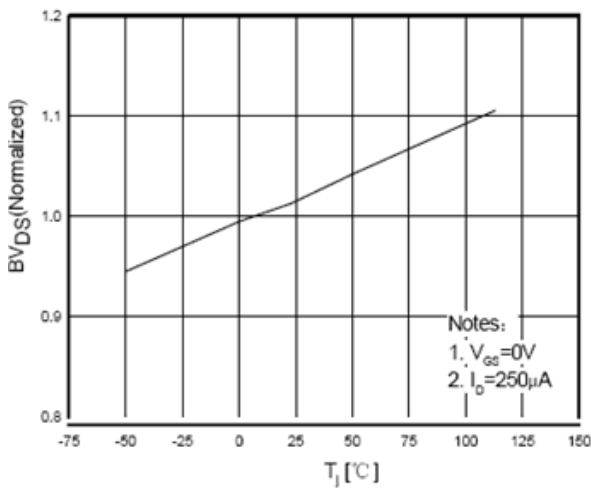

Fig. 3 BV_{DS} vs Junction Temperature

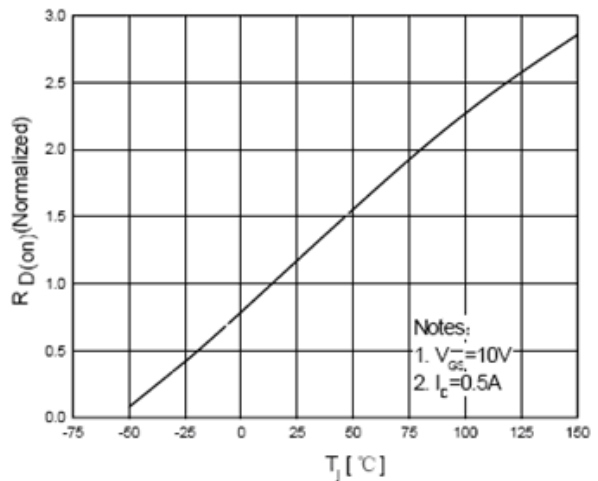

Fig. 4 On-Resistance vs Junction Temperature

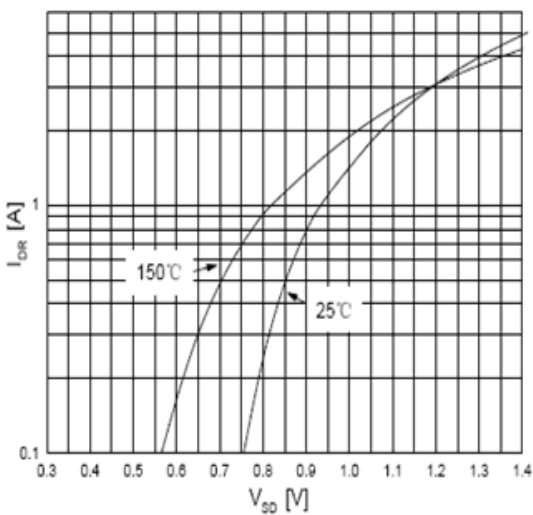

Fig. 5 Forward Characteristic of Reverse Diode

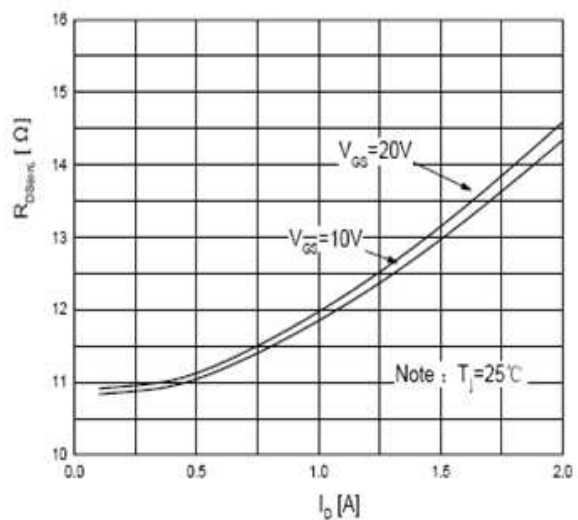

Fig. 6 On-Resistance vs Drain Current



SPN6001 N-Channel Enhancement Mode MOSFET

TYPICAL CHARACTERISTICS

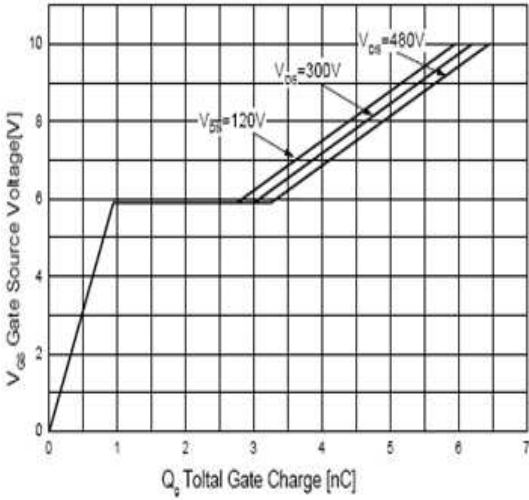

Fig. 7 Gate Charge Characteristics

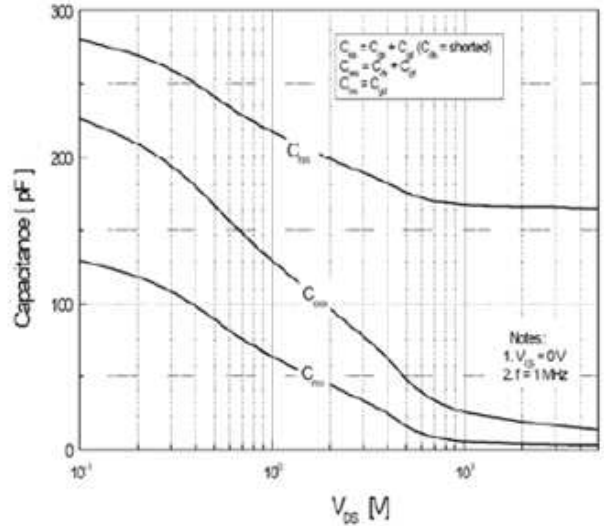

Fig. 8 Typical Capacitance Characteristics

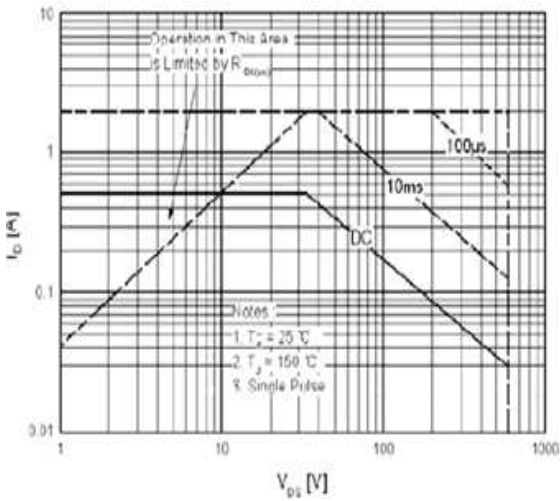

Fig. 9 Maximum Safe Operation Area

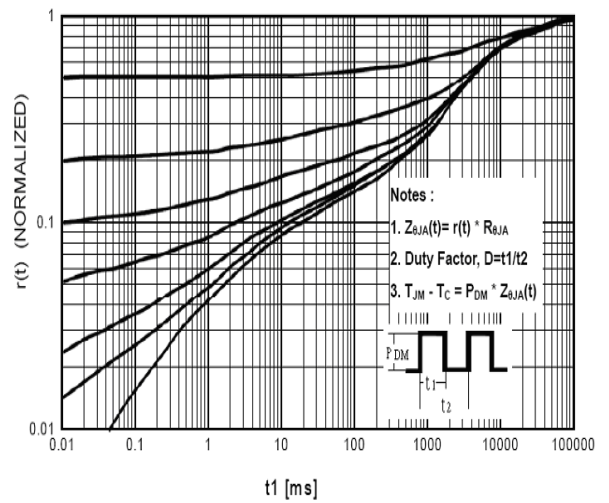

Fig. 10 Effective Transient Thermal Impedance



SPN6001

N-Channel Enhancement Mode MOSFET

TO-92 PACKAGE OUTLINE

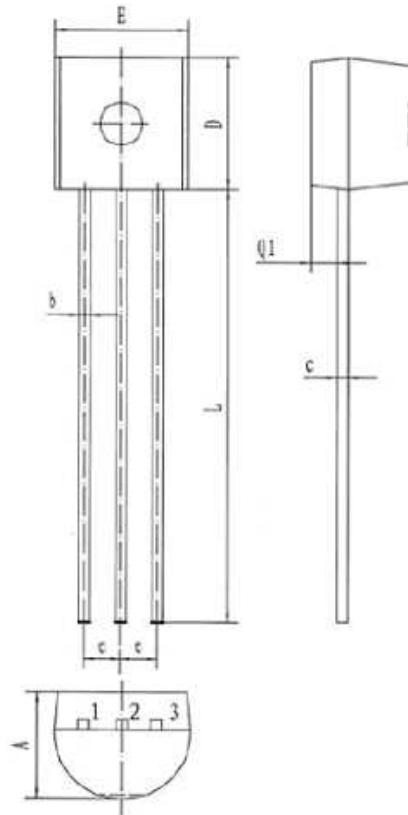

Dimension in mm

symbol	MIN	MAX
A	3.30	3.90
b	0.35	0.55
c	0.31	0.51
D	4.30	4.90
E	4.30	4.90
e	1.17	1.37
L	12.50	15.50
Q1	0.74	0.89



SPN6001

N-Channel Enhancement Mode MOSFET

Information provided is alleged to be exact and consistent. SYNC Power Corporation presumes no responsibility for the penalties of use of such information or for any violation of patents or other rights of third parties which may result from its use. No license is granted by allegation or otherwise under any patent or patent rights of SYNC Power Corporation. Conditions mentioned in this publication are subject to change without notice. This publication surpasses and replaces all information previously supplied. SYNC Power Corporation products are not authorized for use as critical components in life support devices or systems without express written approval of SYNC Power Corporation.

©The SYNC Power logo is a registered trademark of SYNC Power Corporation

©2011 SYNC Power Corporation – Printed in Taiwan – All Rights Reserved

SYNC Power Corporation

7F-2, No.3-1 Park Street

NanKang District (NKSP), Taipei, Taiwan, 115, R.O.C

Phone: 886-2-2655-8178

Fax: 886-2-2655-8468

©<http://www.syncpower.com>