

Radial Lead Resettable Polymer PTCs

SC60 Series

Description

SC60 series radial leaded PTCs are designed to provide over-current protection for low voltage ($\leq 60V$) applications where space is not a concern and resettable protection is preferred.

Features

- u Cured, flame retardant epoxy polymer meets UL 94V-0 requirements
- u 60V operating voltage
- u Fast time-to-trip
- u RoHS compliant, Lead-Free and Halogen-Free

Applications

- u USB hubs ,ports and peripherals
- u Power ports
- u IEEE1394 ports
- u Motor protection
- u Automotive application
- u Computers and peripherals
- u General electronics

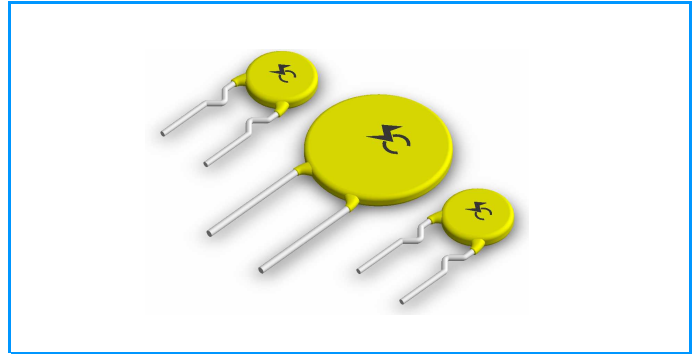

Electrical Parameters

Part Number	I_{hold} (A)	I_{trip} (A)	V_{max} (Vdc)	I_{max} (A)	$P_{dtyp.}$ (W)	Maximum Time To Trip		Resistance		
						Current (A)	Time (Sec.)	R_{min} (Ω)	R_{max} (Ω)	R_{1max} (Ω)
SC60-005	0.05	0.10	60	40	0.22	0.25	5.0	7.30	20.00	30.00
SC60-010	0.10	0.20	60	40	0.38	0.50	4.0	2.50	7.50	12.00
SC60-017	0.17	0.34	60	40	0.48	0.85	3.0	2.00	5.20	8.00
SC60-020	0.20	0.40	60	40	0.41	1.00	2.2	1.50	3.00	4.40
SC60-025	0.25	0.50	60	40	0.45	1.25	2.5	1.10	2.20	3.00
SC60-030	0.30	0.60	60	40	0.49	1.50	3.0	0.80	1.60	2.10
SC60-040	0.40	0.80	60	40	0.56	2.00	3.8	0.50	1.00	1.29
SC60-050	0.50	1.00	60	40	0.77	2.50	4.0	0.45	0.90	1.17
SC60-065	0.65	1.30	60	40	0.88	3.25	5.3	0.30	0.60	0.72
SC60-075	0.75	1.50	60	40	0.92	3.75	6.3	0.25	0.50	0.60
SC60-090	0.90	1.80	60	40	0.99	4.50	7.2	0.20	0.40	0.47
SC60-110	1.10	2.20	60	40	1.50	5.50	8.2	0.15	0.32	0.38
SC60-135	1.35	2.70	60	40	1.70	6.75	9.6	0.12	0.24	0.30
SC60-160	1.60	3.20	60	40	1.90	8.00	11.4	0.09	0.18	0.22
SC60-185	1.85	3.70	60	40	2.10	9.25	12.6	0.08	0.16	0.20
SC60-200	2.00	4.00	60	40	2.10	6.00	20.0	0.08	0.16	0.20
SC60-250	2.50	5.00	60	40	2.50	12.50	15.6	0.05	0.11	0.13
SC60-300	3.00	6.00	60	40	2.80	15.00	19.8	0.04	0.08	0.10
SC60-375	3.75	7.50	60	40	3.20	18.75	24.0	0.03	0.065	0.08
SC60-500	5.00	10.00	60	40	3.20	15.00	25.0	0.025	0.05	0.06

I_{hold} = Hold current: maximum current device will pass without tripping in 25°C still air.

I_{trip} = Trip current: minimum current at which the device will trip in 25°C still air.

V_{max} = Maximum voltage device can withstand without damage at rated current (I_{max})

I_{max} = Maximum fault current device can withstand without damage at rated voltage (V_{max})

$P_{dtyp.}$ = Power dissipated from device when in the tripped state at 25°C still air.

R_{min} = Minimum resistance of device in initial (un-soldered) state.

R_{max} = Maximum resistance of device in initial (un-soldered) state.

R_{1max} = Maximum resistance of device at 25°C measured one hour after tripping.

Caution: Operation beyond the specified rating may result in damage and possible arcing and flame.

Radial Lead Resettable Polymer PTCs

SC60 Series

Temperature Derating Chart – I_{hold} (A)

Part Number	Ambient Operation Temperature								
	-40°C	-20°C	0°C	25°C	40°C	50°C	60°C	70°C	85°C
	Hold Current (A)								
SC60-005	0.078	0.068	0.06	0.05	0.04	0.036	0.032	0.027	0.02
SC60-010	0.16	0.14	0.12	0.10	0.08	0.072	0.063	0.054	0.04
SC60-017	0.26	0.23	0.20	0.17	0.14	0.12	0.11	0.09	0.07
SC60-020	0.31	0.27	0.24	0.20	0.16	0.14	0.13	0.11	0.08
SC60-025	0.39	0.34	0.30	0.25	0.20	0.18	0.16	0.14	0.10
SC60-030	0.47	0.41	0.36	0.30	0.24	0.22	0.20	0.16	0.12
SC60-040	0.62	0.54	0.48	0.40	0.32	0.29	0.25	0.22	0.16
SC60-050	0.78	0.68	0.60	0.50	0.41	0.36	0.32	0.27	0.20
SC60-065	1.01	0.88	0.77	0.65	0.53	0.47	0.41	0.35	0.26
SC60-075	1.16	1.02	0.89	0.75	0.61	0.54	0.47	0.41	0.30
SC60-090	1.40	1.22	1.07	0.90	0.73	0.65	0.57	0.49	0.36
SC60-110	1.71	1.50	1.31	1.10	0.89	0.79	0.69	0.59	0.44
SC60-135	2.09	1.84	1.61	1.35	1.09	0.97	0.85	0.73	0.54
SC60-160	2.48	2.18	1.90	1.60	1.30	1.15	1.01	0.86	0.64
SC60-185	2.87	2.52	2.20	1.85	1.50	1.33	1.17	1.00	0.74
SC60-200	3.10	2.72	2.38	2.00	1.62	1.44	1.26	1.08	0.80
SC60-250	3.88	3.40	2.98	2.50	2.03	1.80	1.58	1.35	1.00
SC60-300	4.65	4.08	3.57	3.00	2.43	2.16	1.89	1.62	1.20
SC60-375	5.81	5.10	4.46	3.75	3.04	2.70	2.36	2.03	1.50
SC60-500	7.75	6.80	5.95	5.00	4.05	3.60	3.15	2.70	2.00

Average Time Current Curves

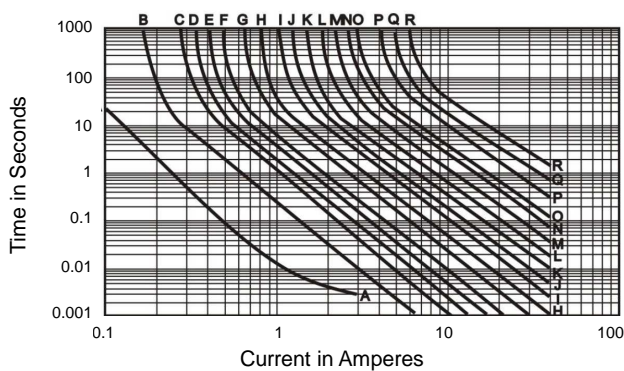

- | | | |
|------------|------------|------------|
| A=SC60-005 | G=SC60-040 | M=SC60-135 |
| B=SC60-010 | H=SC60-050 | N=SC60-160 |
| C=SC60-017 | I=SC60-065 | O=SC60-185 |
| D=SC60-020 | J=SC60-075 | P=SC60-250 |
| E=SC60-025 | K=SC60-090 | Q=SC60-300 |
| F=SC60-030 | L=SC60-110 | R=SC60-375 |

Temperature Derating Curve

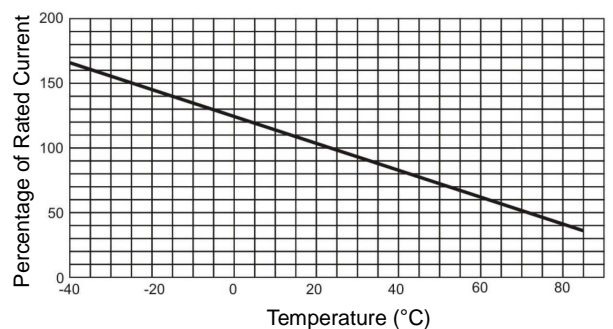

Radial Lead Resettable Polymer PTCs

SC60 Series

Test Procedures and Requirement

Test	Test Conditions	Accept/Reject Criteria
Resistance	In still air @25±2°C	$R_{min} \leq R \leq R_{max}$
Hold Current	60 min, at I_{hold} , In still air @25±2°C	No trip
Time to Trip	Specified current, V_{max} , @25±2°C	$T \leq$ Maximum Time To Trip
Trip Cycle Life	V_{max} , I_{max} , 100 cycles	No arcing or burning
Trip Endurance	V_{max} , 24hours	No arcing or burning

Soldering Parameters

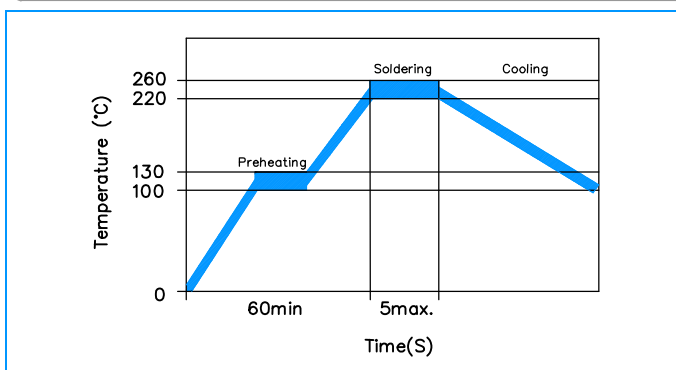

Pre-Heating Zone	Refer to the condition recommended by the manufacturer. Max. ramping rate should not exceed 4°C/Sec
Soldering Zone	Max. solder temperature should not exceed 260°C
Cooling Zone	Cooling by natural convection in air

Physical Specifications

Lead Material	0.05-0.4A Tin-plated Copper clad steel 0.5-3.75A Tin-plated Copper
Soldering Characteristics	Solder ability per MIL-STD-202, Method 208E
Insulating Material	Cured, flame retardant epoxy polymer meets UL 94V-0 requirements.
Device Labeling	Marked with 'SC', voltage, current rating

Part Numbering

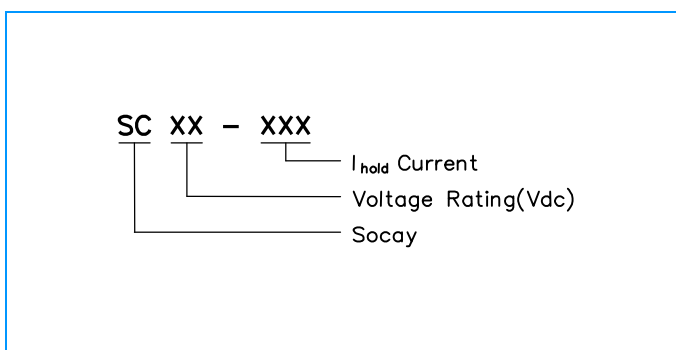

Part Marking

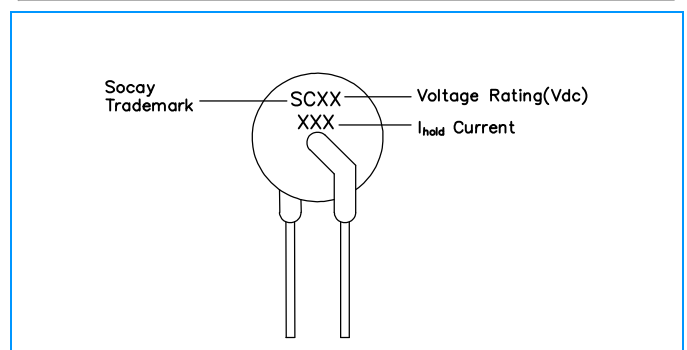

Radial Lead Resettable Polymer PTCs

SC60 Series

Dimensions

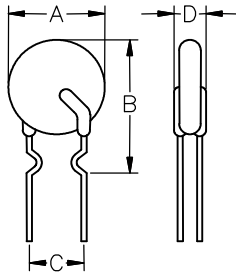

Figure1

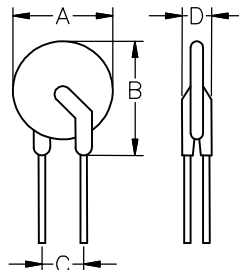

Figure2

Part Number	Figure	A		B		C		D		Lead (dia)		Packaging (Bulk Pack)
		Inches	mm	Inches	mm	Inches	mm	Inches	mm	Inches	Mm	
		Max.	Max.	Max.	Max.	Typ.	Typ.	Max.	Max.			
SC60-005	Figure1	0.236	6.0	0.405	10.3	0.200	5.1	0.122	3.1	0.020	0.5	1000
SC60-010	Figure1	0.236	6.0	0.405	10.3	0.200	5.1	0.122	3.1	0.020	0.5	1000
SC60-017	Figure1	0.236	6.0	0.445	11.3	0.200	5.1	0.122	3.1	0.020	0.5	1000
SC60-020	Figure1	0.236	6.0	0.421	10.7	0.200	5.1	0.122	3.1	0.020	0.5	1000
SC60-025	Figure1	0.236	6.0	0.445	11.3	0.200	5.1	0.122	3.1	0.020	0.5	1000
SC60-030	Figure1	0.236	6.0	0.472	12.0	0.200	5.1	0.122	3.1	0.020	0.5	1000
SC60-040	Figure1	0.276	7.0	0.472	12.0	0.200	5.1	0.122	3.1	0.020	0.5	1000
SC60-050	Figure1	0.283	7.2	0.480	12.2	0.200	5.1	0.122	3.1	0.020	0.5	1000
SC60-065	Figure1	0.346	8.8	0.543	13.8	0.200	5.1	0.122	3.1	0.020	0.5	1000
SC60-075	Figure1	0.374	9.5	0.570	14.5	0.200	5.1	0.122	3.1	0.020	0.5	1000
SC60-090	Figure1	0.421	10.7	0.618	15.7	0.200	5.1	0.122	3.1	0.020	0.5	1000
SC60-110	Figure2	0.480	12.2	0.618	15.7	0.200	5.1	0.122	3.1	0.031	0.8	1000
SC60-135	Figure2	0.543	13.8	0.681	17.3	0.200	5.1	0.122	3.1	0.031	0.8	1000
SC60-160	Figure2	0.614	15.6	0.772	19.6	0.200	5.1	0.122	3.1	0.031	0.8	500
SC60-185	Figure2	0.661	16.8	0.819	20.8	0.200	5.1	0.122	3.1	0.031	0.8	500
SC60-200	Figure2	0.661	16.8	0.819	20.8	0.200	5.1	0.122	3.1	0.031	0.8	500
SC60-250	Figure2	0.811	20.6	0.949	24.1	0.200	5.1	0.122	3.1	0.031	0.8	500
SC60-300	Figure2	0.933	23.7	1.071	27.2	0.200	5.1	0.122	3.1	0.031	0.8	200
SC60-375	Figure2	1.023	26.0	1.161	29.5	0.400	10.2	0.122	3.1	0.031	0.8	200
SC60-500	Figure2	1.023	26.0	1.161	29.5	0.400	10.2	0.122	3.1	0.031	0.8	200

Warning



- ⚠ This product should not be used in an application where the maximum interrupt voltage or maximum interrupt current in a fault condition, Operation beyond the maximum rating or improper use may result in device damage and possible electrical arcing and flame.
- ⚠ A PPTC device is not a fuse, It is a nonlinear thermistor that limits current, Because under a fault condition all PPTC devices go into a high resistance state but not open circuit hazardous voltage may be present at PPTC.
- ⚠ The devices are intended for protection against occasional over-current or over-temperature fault conditions and should not be used when repeated fault conditions or prolonged trip events.
- ⚠ In most application, power must be removed and the fault condition cleared in order to reset a PPTC device.
- ⚠ PPTC devices are not recommended to be installed in applications where the device is constrained such that its PPTC properties are inhibited, for example in rigid potting materials or Add devices surface coating, Bundled devices ontology, which lack adequate clearance to accommodate device expansion.
- ⚠ Contamination on of the PPTC material with certain silicone-based oils or some aggressive solvents can adversely impact the performance of the devices. For example, Organic solvents to cleaning.