

Circuits from the Lab™
Reference Circuits

Circuits from the Lab™ reference circuits are engineered and tested for quick and easy system integration to help solve today's analog, mixed-signal, and RF design challenges. For more information and/or support, visit www.analog.com/CN0311.

Devices Connected/Referenced

ADF4351	Fractional-N PLL IC with Integrated VCO
ADL5385	Wideband Transmit Modulator
ADP150	Low Noise 3.3 V LDO
ADP3334	Low Noise Adjustable LDO

Broadband, Low Error Vector Magnitude (EVM) Direct Conversion Transmitter Using LO Divide-by-2 Modulator

EVALUATION AND DESIGN SUPPORT

Circuit Evaluation Boards

[ADF4351 Evaluation Board \(EVAL-ADF4351EB1Z\)](#)

[ADL5385 Evaluation Board \(ADL5385-EVALZ\)](#)

Design and Integration Files

[Schematics, Layout Files, Bill of Materials](#)

CIRCUIT FUNCTION AND BENEFITS

This circuit is a complete implementation of the analog portion of a broadband direct conversion transmitter (analog baseband in, RF out). RF frequencies from 30 MHz to 2.2 GHz are supported by using a phase-locked loop (PLL) with a broadband integrated voltage controlled oscillator (VCO). Unlike modulators that use a divide-by-1 local oscillator (LO) stage (as described in [CN-0285](#)), harmonic filtering of the LO is not required.

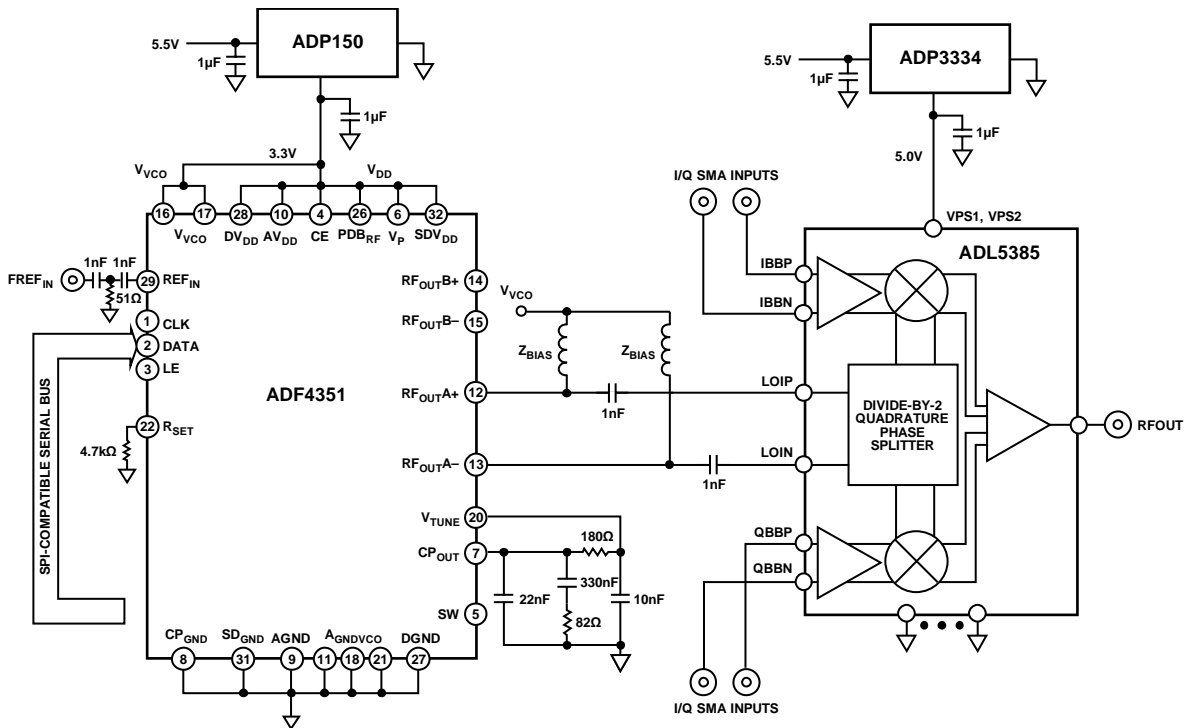

Figure 1. Direct Conversion Transmitter (Simplified Schematic: All Connections and Decoupling Not Shown)

112885-001

Rev. 0

Circuits from the Lab™ circuits from Analog Devices have been designed and built by Analog Devices engineers. Standard engineering practices have been employed in the design and construction of each circuit, and their function and performance have been tested and verified in a lab environment at room temperature. However, you are solely responsible for testing the circuit and determining its suitability and applicability for your use and application. Accordingly, in no event shall Analog Devices be liable for direct, indirect, special, incidental, consequential or punitive damages due to any cause whatsoever connected to the use of any Circuits from the Lab circuits. (Continued on last page)

To achieve optimum performance, the only requirement is that the LO inputs of the modulator be driven differentially. The [ADF4351](#) provides differential RF outputs and is, therefore, an excellent match. This PLL-to-modulator interface is applicable to all I/Q modulators and I/Q demodulators that contain a 2XLO-based phase splitter. Low noise LDOs ensure that the power management scheme has no adverse impact on phase noise and error vector magnitude (EVM). This combination of components represents an industry-leading direct conversion transmitter performance over a frequency range of 30 MHz to 2.2 GHz. For frequencies above 2.2 GHz, it is recommended to use a divide-by-1 modulator, as described in [CN-0285](#).

CIRCUIT DESCRIPTION

The circuit shown in Figure 1 uses the [ADF4351](#), a fully integrated fractional-N PLL IC, and the [ADL5385](#) wideband transmit modulator. The [ADF4351](#) provides the local oscillator (the LO is twice the modulator RF output frequency) signal for the [ADL5385](#) transmit quadrature modulator, which upconverts the analog I/Q signals to RF. Taken together, the two devices provide a wideband, baseband I/Q-to-RF transmit solution.

The [ADF4351](#) is powered off the ultralow noise 3.3 V [ADP150](#) regulator for optimal LO phase noise performance. The [ADL5385](#) is powered off a 5 V [ADP3334](#) LDO. The [ADP150](#) LDO has an output voltage noise of only 9 μ V rms, integrated from 10 Hz to 100 kHz, and helps to optimize VCO phase noise and reduce the impact of VCO pushing (equivalent to power supply rejection). See [CN-0147](#) for more details on powering the [ADF4351](#) with the [ADP150](#) LDO.

The [ADL5385](#) uses a divide-by-2 block to generate the quadrature LO signals. The quadrature accuracy is, thus, dependent on the duty cycle accuracy of the incoming LO signal (as well as the matching of the internal divider flip-flops). Any imbalance in the rise and fall times causes even-order harmonics to appear, as evident on the [ADF4351](#) RF outputs. When driving the modulator LO inputs differentially, even-order cancellation of harmonics is achieved, improving the overall quadrature generation. (See “Wideband A/D Converter Front-End Design Considerations: When to Use a Double Transformer Configuration.” Rob Reeder and Ramya Ramachandran. *Analog Dialogue*, 40-07.)

Because sideband suppression performance is dependent on the modulator quadrature accuracy, better sideband suppression is achievable when driving the LO input ports differentially vs. single-ended. The [ADF4351](#) has differential RF outputs compared to the single-ended output available on most of the competitor’s PLL devices with integrated VCOs.

The [ADF4351](#) output match consists of the Z_{BIAS} pull-up and, to a lesser extent, the decoupling capacitors on the supply node. To get a broadband match, it is recommended to use either a resistive load ($Z_{BIAS} = 50 \Omega$) or a resistive in parallel with a reactive load for Z_{BIAS} . The latter gives slightly higher output power, depending on the inductor chosen. Use an inductor value of 19 nH or greater for LO operation below 1 GHz. The measured results in this circuit were performed using $Z_{BIAS} = 50 \Omega$ and an output power setting of 5 dBm. When using the 50 Ω resistor, this setting gives approximately 0 dBm on each output across the full band, or 3 dBm differentially. The [ADL5385](#) LO input drive level specification is -10 dBm to $+5$ dBm; therefore, it is possible to reduce the [ADF4351](#) output power to save current.

A sweep of sideband suppression vs. RF output frequency is shown in Figure 2. In this sweep, the test conditions were as follows:

- Baseband I/Q amplitude = 1.4 V p-p differential sine waves in quadrature with a 500 mV dc bias
- Baseband I/Q frequency (f_{BB}) = 1 MHz
- LO = $2 \times RF_{OUT}$

A simplified diagram of the test setup is shown in Figure 3. A modified [ADL5385](#) evaluation board was used because the standard [ADL5385](#) board does not allow a differential LO input drive.

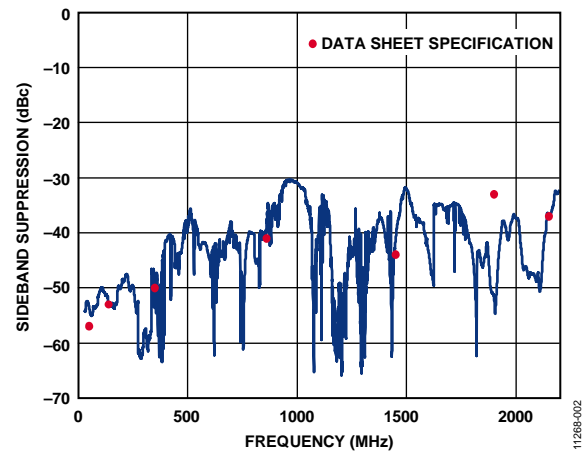

Figure 2. Sideband Suppression, RF_{OUT} Swept from 30 MHz to 2200 MHz

This circuit achieves comparable or improved sideband suppression performance when compared to driving the [ADL5385](#) with a low noise RF signal generator, as used in the data sheet measurement. Using the differential RF outputs of the [ADF4351](#) provides even-order harmonic cancellation and improves modulator quadrature accuracy. This affects sideband suppression performance and EVM. A single carrier W-CDMA composite EVM of better than 2% was measured with the circuit shown in Figure 1. The solution thus provides a low EVM broadband solution for frequencies from 30 MHz to 2.2 GHz. For frequencies above 2.2 GHz, use a divide-by-1 modulator block, as described in [CN-0285](#).

The complete design support package can be found at <http://www.analog.com/CN0311-DesignSupport>.

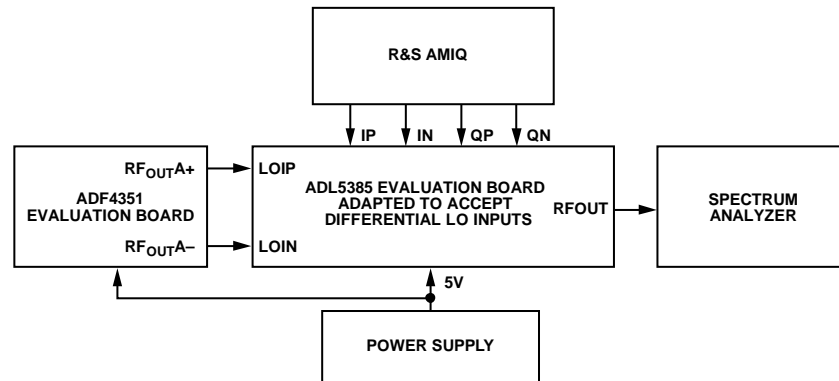

Figure 3. Sideband Suppression Measurement Test Setup (Simplified Diagram)

COMMON VARIATIONS

The PLL-to-modulator interface described is applicable to all I/Q modulators that contain a 2XLO-based phase splitter. It is also applicable to 2XLO-based I/Q demodulators, such as the [ADL5387](#).

CIRCUIT EVALUATION AND TEST

The [CN-0311](#) uses the [EVAL-ADF4351EB1Z](#) and the [ADL5385-EVALZ](#) for the evaluation of the described circuit, allowing for quick setup and evaluation. The [EVAL-ADF4351EB1Z](#) uses the standard [ADF4351](#) programming software contained on the CD that accompanies the evaluation board.

Equipment Needed

The following equipment is needed:

- A PC with a USB port that contains Windows® XP, Vista, or Windows 7
- The [EVAL-ADF4351EB1Z](#) evaluation board
- The [ADL5385-EVALZ](#) evaluation board,
- [ADF4351](#) programming software
- Power supplies (5 V, 500 mA)
- An I-Q signal source, such as a Rohde & Schwarz AMIQ
- A spectrum analyzer

Also, see the [UG-435](#) User Guide for the [EVAL-ADF4351EB1Z](#) evaluation board, the [ADF4351](#) data sheet, and the [ADL5385](#) data sheet.

Getting Started

A description of the circuit, the schematic, and a block diagram of the test setup is detailed within the [CN-0311](#) (see Figure 1 and Figure 3). The [UG-435](#) user guide details the installation and use of the [EVAL-ADF4351EB1Z](#) evaluation software. The [UG-435](#) also contains the board setup instructions, and the board schematic, layout, and bill of materials. The [ADL5385-EVALZ](#) board schematic, block diagram, bill of materials, layout, and assembly information is included in the [ADL5385](#) data sheet. See the [ADF4351](#) data sheet and [ADL5385](#) data sheet for device information.

Functional Block Diagram

The functional block diagram of the described test setup is shown in Figure 3.

Setup and Test

After setting up the equipment, use standard RF test methods to measure the sideband suppression of the circuit.

11268-003

LEARN MORE

CN0311 Design Support Package:

<http://www.analog.com/CN0311-DesignSupport>

ADIsimPLL Design Tool

ADIsimPower Design Tool

ADIsimRF Design Tool

Brandon, David, David Crook, and Ken Gentile. AN-0996

Application Note, *The Advantages of Using a Quadrature Digital Upconverter (QDUC) in Point-to-Point Microwave Transmit Systems*. Analog Devices.

CN-0134, *Broadband Low EVM Direct Conversion Transmitter*.

Analog Devices.

CN-0147, *Using the ADP150 LDO Regulators to Power the*

ADF4350 PLL and VCO. Analog Devices.

Nash, Eamon. AN-1039 Application Note, *Correcting*

Imperfections in IQ Modulators to Improve RF Signal Fidelity. Analog Devices.

Reeder, Rob, and Ramya Ramachandran. "Wideband A/D

Converter Front-End Design Considerations: When to Use a Double Transformer Configuration." *Analog Dialogue*, 40-07.

Data Sheets and Evaluation Boards

[ADF4351 Data Sheet](#)

[ADF4351 Evaluation Board](#)

[ADL5385 Data Sheet](#)

[ADL5385 Evaluation Board](#)

[ADP150 Data Sheet](#)

[ADP3334 Data Sheet](#)

REVISION HISTORY

12/12—Revision 0: Initial Version

(Continued from first page) Circuits from the Lab circuits are intended only for use with Analog Devices products and are the intellectual property of Analog Devices or its licensors. While you may use the Circuits from the Lab circuits in the design of your product, no other license is granted by implication or otherwise under any patents or other intellectual property by application or use of the Circuits from the Lab circuits. Information furnished by Analog Devices is believed to be accurate and reliable. However, Circuits from the Lab circuits are supplied "as is" and without warranties of any kind, express, implied, or statutory including, but not limited to, any implied warranty of merchantability, noninfringement or fitness for a particular purpose and no responsibility is assumed by Analog Devices for their use, nor for any infringements of patents or other rights of third parties that may result from their use. Analog Devices reserves the right to change any Circuits from the Lab circuits at any time without notice but is under no obligation to do so.