

TO-92 Plastic-Encapsulate Transistors

3DG3332 TRANSISTOR (NPN)

FEATURES

- Low Current
- High Voltage

APPLICATIONS

- Video
- Telephony
- Professional Communication Equipment

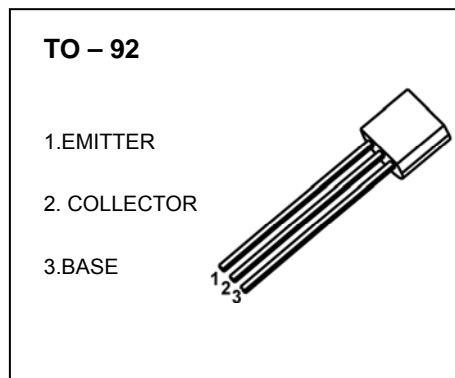

MAXIMUM RATINGS (T_a=25°C unless otherwise noted)

Symbol	Parameter	Value	Unit
V _{CB0}	Collector-Base Voltage	180	V
V _{CEO}	Collector-Emitter Voltage	160	V
V _{EBO}	Emitter-Base Voltage	6	V
I _C	Collector Current	0.7	A
P _C	Collector Power Dissipation	625	mW
R _{θJA}	Thermal Resistance From Junction To Ambient	200	°C/W
T _j	Junction Temperature	150	°C
T _{stg}	Storage Temperature	-55~+150	°C

ELECTRICAL CHARACTERISTICS (T_a=25°C unless otherwise specified)

Parameter	Symbol	Test conditions	Min	Typ	Max	Unit
Collector-base breakdown voltage	V _{(BR)CBO}	I _C = 0.01mA, I _E =0	180			V
Collector-emitter breakdown voltage	V _{(BR)CEO}	I _C =1mA, I _B =0	160			V
Emitter-base breakdown voltage	V _{(BR)EBO}	I _E =0.01mA, I _C =0	6			V
Collector cut-off current	I _{CBO}	V _{CB} =120V, I _E =0			0.1	μA
Emitter cut-off current	I _{EBO}	V _{EB} =4V, I _C =0			0.1	μA
DC current gain	h _{FE(1)}	V _{CE} =5V, I _C =100mA	100		400	
	h _{FE(2)}	V _{CE} =5V, I _C =10mA	80			
Collector-emitter saturation voltage	V _{CE(sat)(1)}	I _C =250mA, I _B =25mA			0.4	V
Base-emitter saturation voltage	V _{BE (sat)}	I _C =250mA, I _B =25mA			1.2	V
Transition frequency	f _T	V _{CE} =10V, I _C =50mA		120		MHz
Collector output capacitance	C _{ob}	V _{CB} =10V, I _E =0, f=1MHz		8		pF

CLASSIFICATION OF h_{FE(1)}

RANK	R	S	T
RANGE	100-200	140-280	200-400