

RS6512A

2A, 20V, 1.2MHz DC/DC Asynchronous Step-Down Converter

General Description

The RS6512A is a high-efficiency asynchronous step-down DC/DC converter that can deliver up to 2A output current from 4.75V to 20V input supply. The RS6512A's current mode architecture and external compensation allow the transient response to be optimized over a wide range of loads and output capacitors. Cycle-by-cycle current limit provides protection against shorted outputs and thermal shutdown protection.

The RS6512A also provides output under voltage protection and thermal shutdown protection. The low current (<30µA) shutdown mode provides output disconnection, enabling easy power management in battery-powered systems.

Features

- 2A Output Current
- Up to 93% Efficiency
- Integrated 100mΩ Power MOSFET Switches
- Fixed 1.2MHz Frequency
- Cycle-by-Cycle Over Current Protection
- Thermal Shutdown function
- Wide 4.75V to 20V Operating Input Range
- Output Adjustable from 1.23V to 18V
- Programmable Under Voltage Lockout
- Available in an SOP-8 Package
- RoHS Compliant and 100% Lead (Pb)-Free and Green (Halogen Free with Commercial Standard)

Applications

- PC Motherboard, Graphic Card
- LCD Monitor
- Set-Top Boxes
- DVD-Video Player
- Telecom Equipment
- ADSL Modem
- Printer and other Peripheral Equipment
- Microprocessor core supply
- Networking power supply
- Pre-Regulator for Linear Regulators
- Green Electronics/Appliances

Application Circuits

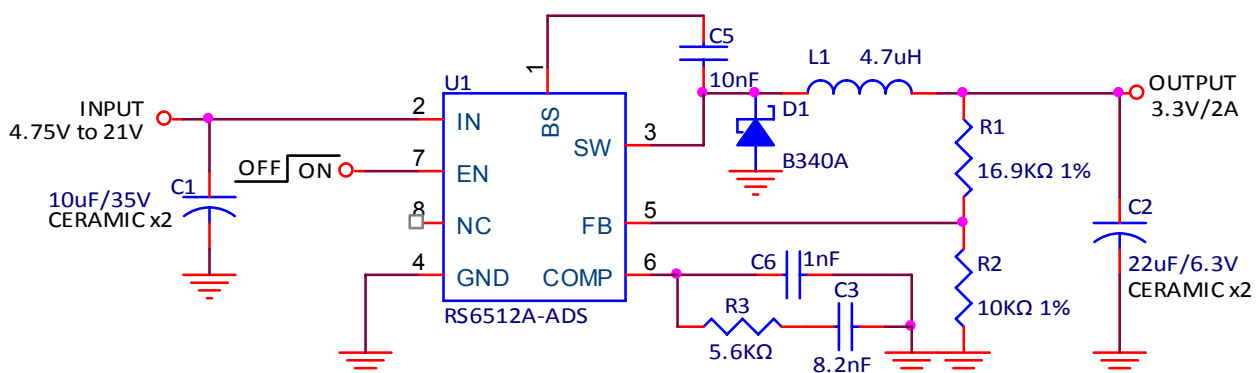

This integrated circuit can be damaged by ESD. Orister Corporation recommends that all integrated circuits be handled with appropriate precautions. Failure to observe proper handling and installation procedures can cause damage.

ESD damage can range from subtle performance degradation to complete device failure. Precision integrated circuits may be more susceptible to damage because very small parametric changes could cause the device not to meet its published specifications.

Pin Assignments

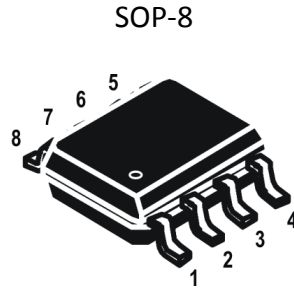

PACKAGE	PIN	SYMBOL	DESCRIPTION
SOP-8	1	BS	Bootstrap. This capacitor (C5) is needed to drive the power switch's gate above the supply voltage. It is connected between the SW and BS pins to form a floating supply across the power switch driver. The voltage across C5 is about 5V and is supplied by the internal +5V supply when the SW pin voltage is low.
	2	IN	Supply Voltage. The RS6512A operates from a 4.75V to 20V unregulated input. C1 is needed to prevent large voltage spikes from appearing at the input.
	3	SW	Power Switching Output. SW is the switching node that supplies power to the output. Connect the output LC filter from SW to the output load. Note that a capacitor is required from SW to BS to power the high-side switch.
	4	GND	Ground.
	5	FB	Feedback Input. FB senses the output voltage and regulates it. Drive FB with a resistive voltage divider from the output voltage to ground. The feedback threshold is 1.23V. See Setting the Output Voltage.
	6	COMP	Compensation Node. COMP is used to compensate the regulation control loop. Connect a series RC network from COMP to GND. In some cases, an additional capacitor from COMP to GND is required. See Compensation.
	7	EN	Enable Input. EN is a digital input that turns the regulator on or off. Drive EN high to turn on the regulator, drive it low to turn it off. For automatic startup, leave EN unconnected.
	8	NC	No internal connection.

Ordering Information

DEVICE	DEVICE CODE
RS6512A-XX Y Z	<p>XX is nominal output voltage :</p> <p>AD : ADJ</p> <p>Y is package & Pin Assignments designator :</p> <p>S : SOP-8</p> <p>Z is Lead Free designator :</p> <p>P: Commercial Standard, Lead (Pb) Free and Phosphorous (P) Free Package</p> <p>G: Green (Halogen Free with Commercial Standard)</p>

Block Diagram

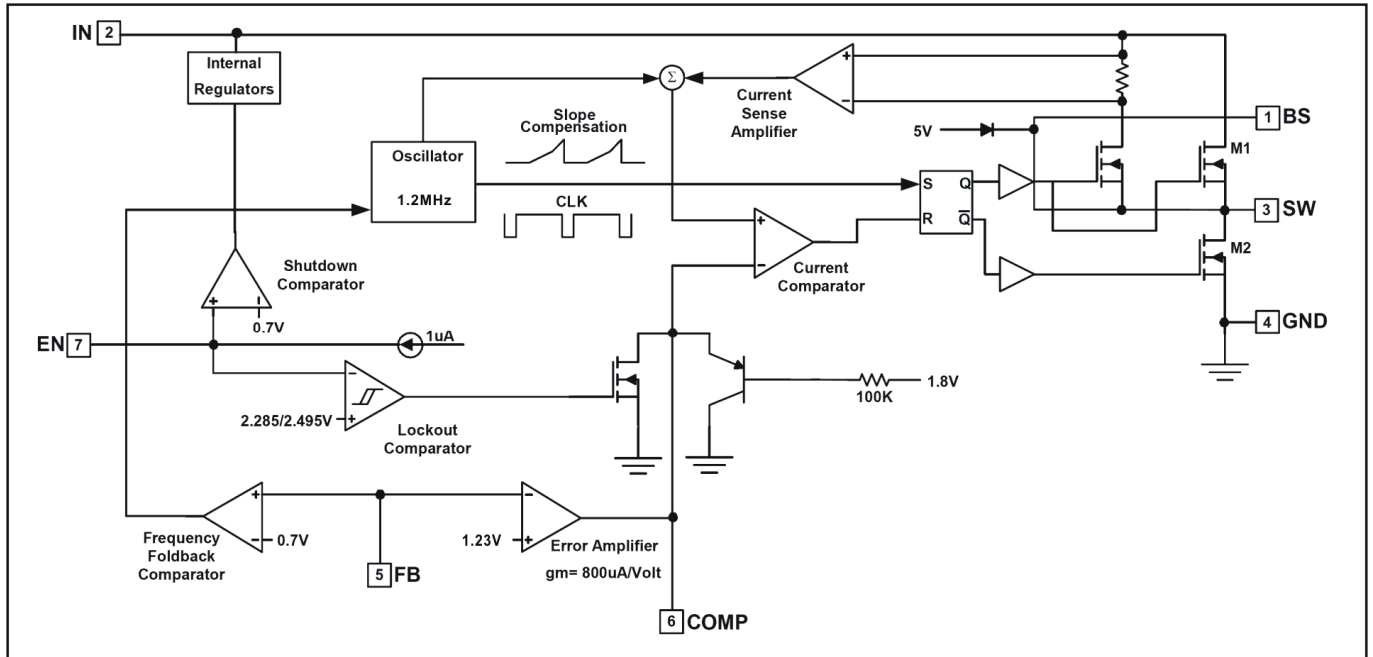

Absolute Maximum Ratings

Symbol	Parameter	Range	Units
V_{IN}	Supply Voltage	-0.3 to +21	V
V_{SW}	SW Pin Voltage	-0.3 to $V_{IN} + 0.3$	V
V_{BS}	Boot Strap Voltage	$V_{SW} - 0.3$ to $V_{SW} + 6$	V
V_{FB}	Feedback Voltage	-0.3 to +6	V
V_{EN}	Enable/UVLO Voltage	-0.3 to +6	V
V_{COMP}	Comp Voltage	-0.3 to +6	V
T_J	Junction Temperature	150	°C
T_{OPR}	Operating Temperature Range	-20 to +85	°C
T_{STG}	Storage Temperature Range	-65 to +150	°C
T_{LEAD}	Lead Temperature	260	°C

Electrical Characteristics ($V_{IN}=12V$, $T_A=25^{\circ}C$, unless otherwise specified)

Symbol	Parameter	Conditions	Min.	Typ.	Max.	Unit
V_{IN}	Input Voltage	-	4.75	-	20	V
V_{FB}	Feedback Voltage	$4.75V \leq V_{IN} \leq 20V$	1.19	1.23	1.26	V
$R_{DS(ON)1}$	Upper Switch On Resistance	-	-	0.22	-	Ω
$R_{DS(ON)2}$	Lower Switch On Resistance	-	-	10	-	Ω
I_{SW}	Upper Switch Leakage	$V_{EN} = 0V, V_{SW} = 0V$	-	-	10	μA
I_{LIM}	Current Limit ^(NOTE 1)	-	-	3.8	-	A
G_{CS}	Current Sense Transconductance Output Current to Comp Pin Voltage	-	-	1.95	-	A/V
A_{VEA}	Error Amplifier Voltage Gain	-	-	400	-	V/V
G_{EA}	Error Amplifier Transconductance	-	550	830	1150	$\mu A/V$
F_S	Oscillator Frequency	-	-	1.2	-	MHz
F_{OSC1}	Short Circuit Frequency	$V_{FB} = 0V$	-	240	-	KHz
D_{MAX}	Maximum Duty Cycle	$V_{FB} = 1.0V$	-	90	-	%
t_{ON}	Minimum On Time	-	-	100	-	ns
-	EN Shutdown Threshold	$I_{CC} > 100\mu A$	0.7	1.0	1.3	V
-	Enable Pull Up Current	$V_{EN} = 0V$	-	1.0	-	μA
-	EN UVLO Threshold Rising	V_{IN} Rising	2.35	2.50	2.65	V
-	EN UVLO Threshold Hysteresis	-	-	200	-	mV
I_{SD}	Supply Current (Shutdown)	$V_{IN} \leq 0.4V$	-	23	36	μA
I_Q	Supply Current (Quiescent)	$V_{EN} \geq 3V$	-	1.1	1.3	mA
T_{SD}	Thermal Shutdown	-	-	160	-	$^{\circ}C$

Notes:

- Slope compensation changes current limit above 40% duty cycle.
- Stresses listed as the above "Absolute Maximum Ratings" may cause permanent damage to the device. These are for stress ratings. Functional operation of the device at these or any other conditions beyond those indicated in the operational sections of the specifications is not implied. Exposure to absolute maximum rating conditions for extended periods may remain possibility to affect device reliability.
- Devices are ESD sensitive. Handling precaution is recommended.
- The device is not guaranteed to function outside its operating conditions.
- θ_{JA} is measured in the natural convection at $T_A = 25^{\circ}C$ on a high effective four layers thermal conductivity test board of JEDEC 51-7 thermal measurement standard.

Detail Description

The RS6512A is a synchronous high voltage buck converter that can support the input voltage range from 4.75V to 20V and the output current can be up to 2A.

Output Voltage Setting

The resistive divider allows the FB pin to sense the output voltage as shown in Figure 1.

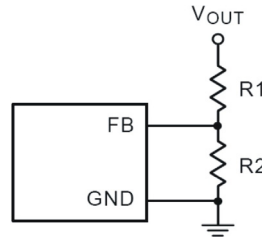

Figure 1. Output Voltage Setting

The output voltage is set by an external resistive divider according to the following equation :

$$V_{OUT} = V_{FB} \left(1 + \frac{R1}{R2} \right)$$

Where VFB is the feedback reference voltage (1.23V typ.).

External Bootstrap Diode

Connect a 10nF low ESR ceramic capacitor between the BOOT pin and SW pin. This capacitor provides the gate driver voltage for the high side MOSFET.

It is recommended to add an external bootstrap diode between an external 5V and the BOOT pin for efficiency improvement when input voltage is lower than 5.5V or duty ratio is higher than 65%. The bootstrap diode can be a low cost one such as 1N4148 or BAT54.

Inductor Selection

The inductor value and operating frequency determine the ripple current according to a specific input and output voltage. The ripple current ΔI_L increases with higher V_{IN} and decreases with higher inductance.

$$\Delta I_L = \left[\frac{V_{OUT}}{f \times L} \right] \times \left[1 - \frac{V_{OUT}}{V_{IN}} \right]$$

Having a lower ripple current reduces not only the ESR losses in the output capacitors but also the output voltage ripple. High frequency with small ripple current can achieve highest efficiency operation. However, it requires a large inductor to achieve this goal.

For the ripple current selection, the value of $\Delta I_L = 0.2375(I_{MAX})$ will be a reasonable starting point. The largest ripple current occurs at the highest V_{IN} . To guarantee that the ripple current stays below the specified maximum, the inductor value should be chosen according to the following equation :

$$L = \left[\frac{V_{OUT}}{f \times \Delta I_L(MAX)} \right] \times \left[1 - \frac{V_{OUT}}{V_{IN(MAX)}} \right]$$

Inductor Core Selection

The inductor type must be selected once the value for L is known. Generally speaking, high efficiency converters can not afford the core loss found in low cost powdered iron cores. So, the more expensive ferrite or mollypermalloy cores will be a better choice.

The selected inductance rather than the core size for a fixed inductor value is the key for actual core loss. As the inductance increases, core losses decrease. Unfortunately, increase of the inductance requires more turns of wire and therefore the copper losses will increase.

Ferrite designs are preferred at high switching frequency due to the characteristics of very low core losses. So, design goals can focus on the reduction of copper loss and the saturation prevention.

Ferrite core material saturates “hard”, which means that inductance collapses abruptly when the peak design current is exceeded. The previous situation results in an abrupt increase in inductor ripple current and consequent output voltage ripple.

Do not allow the core to saturate! Different core materials and shapes will change the size/ current and price/current relationship of an inductor.

Toroid or shielded pot cores in ferrite or permalloy materials are small and do not radiate energy. However, they are usually more expensive than the similar powdered iron inductors. The rule for inductor choice mainly depends on the price vs. size requirement and any radiated field/EMI requirements.

C_{IN} and C_{OUT} Selection

The input capacitance, C_{IN}, is needed to filter the trapezoidal current at the source of the high side MOSFET. To prevent large ripple current, a low ESR input capacitor sized for the maximum RMS current should be used. The RMS current is given by :

$$I_{RMS} = I_{OUT(MAX)} \cdot \frac{V_{OUT}}{V_{IN}} \cdot \sqrt{\frac{V_{IN}}{V_{OUT}} - 1}$$

This formula has a maximum at V_{IN} = 2V_{OUT}, where I_{RMS} = I_{OUT}/2. This simple worst-case condition is commonly used for design because even significant deviations do not offer much relief.

Choose a capacitor rated at a higher temperature than required. Several capacitors may also be paralleled to meet size or height requirements in the design.

For the input capacitor, a 10μF x 2 low ESR ceramic capacitor is recommended. For the recommended capacitor, please refer to table 3 for more detail. The selection of C_{OUT} is determined by the required ESR to minimize voltage ripple.

Moreover, the amount of bulk capacitance is also a key for C_{OUT} selection to ensure that the control loop is stable. Loop stability can be checked by viewing the load transient response as described in a later section. The output ripple, ΔV_{OUT}, is determined by :

$$\Delta V_{OUT} \leq \Delta I_L \cdot \left[ESR + \frac{1}{8fC_{OUT}} \right]$$

The output ripple will be highest at the maximum input voltage since ΔI_L increases with input voltage. Multiple capacitors placed in parallel may be needed to meet the ESR and RMS current handling requirement. Dry tantalum, special polymer, aluminum electrolytic and ceramic capacitors are all available in surface mount packages. Special polymer capacitors offer very low ESR value. However, it provides lower capacitance density than other types. Although Tantalum capacitors have the highest capacitance density, it is important to only use types that pass the surge test for use in switching power supplies. Aluminum electrolytic capacitors have significantly higher ESR. However, it can be used in cost-sensitive applications for ripple current rating and long term reliability considerations. Ceramic capacitors have excellent low ESR characteristics but can have a high voltage coefficient and audible piezoelectric effects. The high Q of ceramic capacitors with trace inductance can also lead to significant ringing.

Higher values, lower cost ceramic capacitors are now becoming available in smaller case sizes. Their high ripple current, high voltage rating and low ESR make them ideal for switching regulator applications. However, care must be taken when these capacitors are used at input and output. When a ceramic capacitor is used at the input and the power is supplied by a wall adapter through long wires, a load step at the output can induce ringing at the input, V_{IN}. At best, this ringing can couple to the output and be mistaken as loop instability. At worst, a sudden inrush of current through the long wires can potentially cause a voltage spike at V_{IN} large enough to damage the part.

Output Rectifier Diode

The output rectifier diode supplies the current to the inductor when the high-side switch is off. To reduce losses due to the diode forward voltage and recovery times, use a Schottky diode.

Choose a diode whose maximum reverse voltage rating is greater than the maximum input voltage, and whose current rating is greater than the maximum load current.

Choose a rectifier who's maximum reverse voltage rating is greater than the maximum input voltage, and who's current rating is greater than the maximum load current.

Checking Transient Response

The regulator loop response can be checked by looking at the load transient response. Switching regulators take several cycles to respond to a step in load current. When a load step occurs, V_{OUT} immediately shifts by an amount equal to $\Delta I_{LOAD} (ESR)$ also begins to charge or discharge C_{OUT} generating a feedback error signal for the regulator to return V_{OUT} to its steady-state value. During this recovery time, V_{OUT} can be monitored for overshoot or ringing that would indicate a stability problem.

Table 1. Suggested Inductors for Typical Application Circuit

Component Supplier	Series	Dimensions (mm)
COILTRONICS	DR73-4R7	6.0 x 7.6 x 3.5
MAGLAYERS	MSCH-5750C-4R67M	5.7 x 5.0 x 4.7
TOKO	A916CY-4R7M	6.2 x 6.2 x 3.5

Table 2. Suggested Capacitors for C_{IN} and C_{OUT}

Component Supplier	Part No.	Capacitance (uF)	Case Size
MURATA	GRM31CR61E106K	10	1206
TDK	C3225X5R1E106K	10	1206
MURATA	GRM32ER71C226M	22	1200
TDK	C3225X5R1C226M	22	1200

Table 3. Schottky Rectifier Selection Guide

V_{IN} (Max.)	2A Load Current	
	Part No.	Vendor
20V	B320	Diodes, Inc. (www.diodes.com)
	SK33	Pan Jit International (www.panjit.com.tw)
	SS32	General Semiconductor (www.gensemi.com)
26V	B330	Diodes, Inc. (www.diodes.com)
	B340L	Diodes, Inc. (www.diodes.com)
	SK33	Diodes, Inc. (www.diodes.com)
	MBRD330	On Semiconductor (www.onsemi.com)
	SS33	Fairchild Semiconductor (www.fairchildsemi.com) General Semiconductor (www.gensemi.com)

SOP-8 Dimension

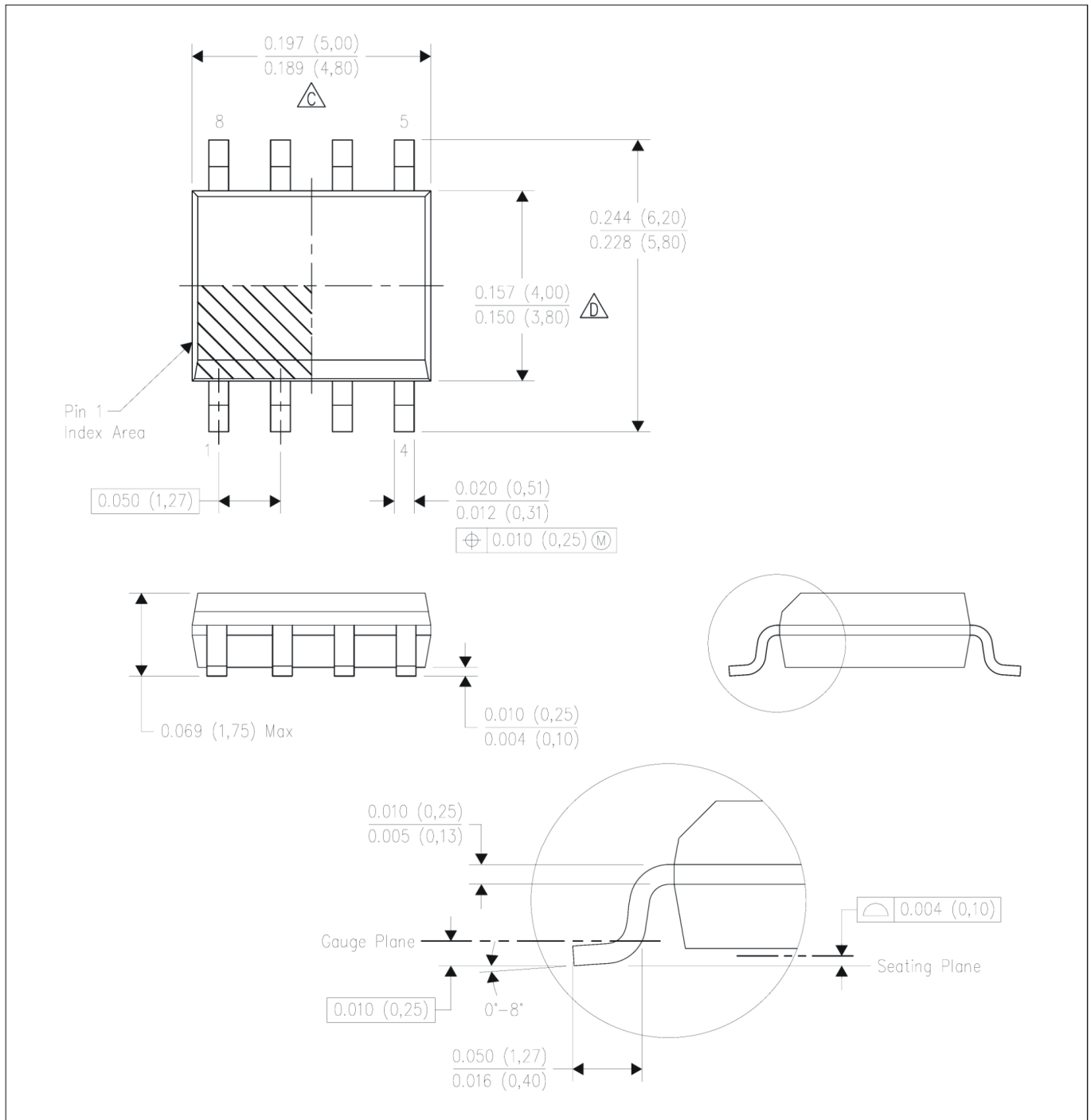

NOTES:

- All linear dimensions are in millimeters (inches).
- This drawing is subject to change without notice.
- Body length does not include mold flash, protrusions, or gate burrs. Mold flash, protrusions, or gate burrs shall not exceed 0.006 (0.15) per end.
- Body width does not include interlead flash. Interlead flash shall not exceed 0.017 (0.43) per side.
- Falls within JEDEC MS-012 variation AA.

Soldering Methods for Orister's Products

1. Storage environment: Temperature=10°C~35°C Humidity=65%±15%
2. Reflow soldering of surface-mount devices

Figure 1: Temperature profile

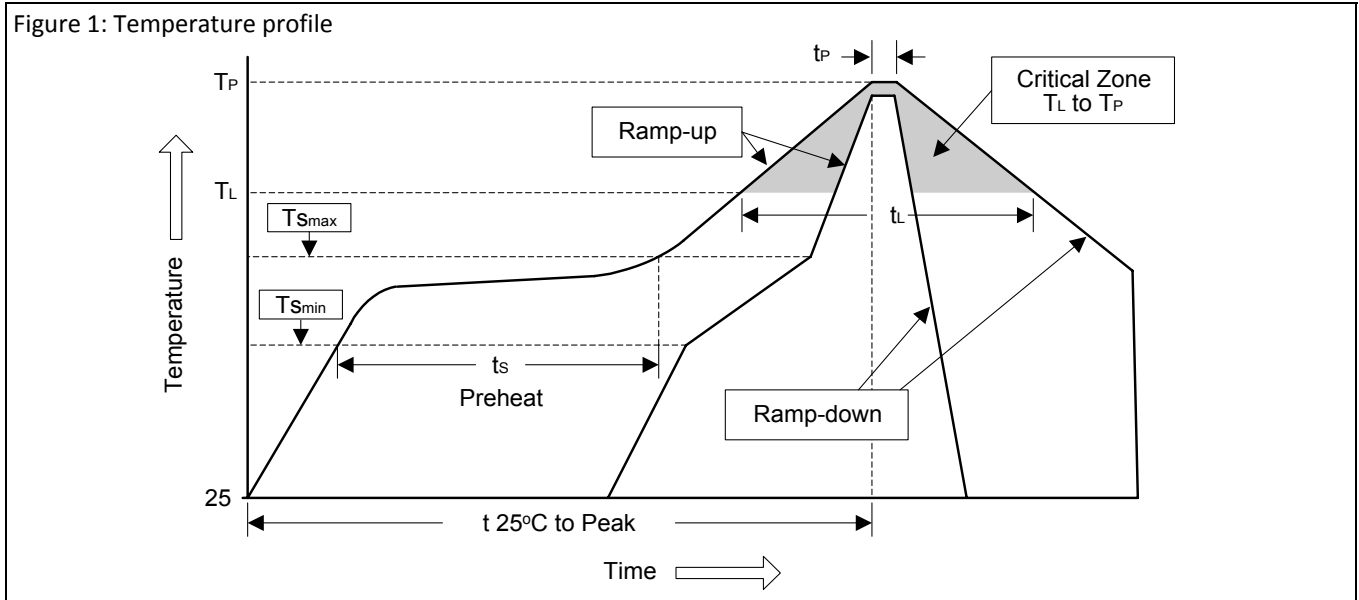

Profile Feature	Sn-Pb Eutectic Assembly	Pb-Free Assembly
Average ramp-up rate (T_L to T_P)	<3°C/sec	<3°C/sec
Preheat		
- Temperature Min (T_{Smin})	100°C	150°C
- Temperature Max (T_{Smax})	150°C	200°C
- Time (min to max) (t_s)	60~120 sec	60~180 sec
T_{Smax} to T_L		
- Ramp-up Rate	<3°C/sec	<3°C/sec
Time maintained above:		
- Temperature (T_L)	183°C	207°C
- Time (t_L)	60~150 sec	60~150 sec
Peak Temperature (T_P)	240°C +0/-5°C	260°C +0/-5°C
Time within 5°C of actual Peak Temperature (t_p)	10~30 sec	20~40 sec
Ramp-down Rate	<6°C/sec	<6°C/sec
Time 25°C to Peak Temperature	<6 minutes	<8 minutes

3. Flow (wave) soldering (solder dipping)

Products	Peak temperature	Dipping time
Pb devices.	245°C ±5°C	5sec ±1sec
Pb-Free devices.	260°C +0/-5°C	5sec ±1sec

Important Notice:

© Orister Corporation

Orister cannot assume responsibility for use of any circuitry other than circuitry entirely embodied in an Orister product. No circuit patent licenses, copyrights, mask work rights, or other intellectual property rights are implied.

Orister reserves the right to make changes to their products or specifications or to discontinue any product or service without notice. Except as provided in Orister's terms and conditions of sale, Orister assumes no liability whatsoever, and Orister disclaims any express or implied warranty relating to the sale and/or use of Orister products including liability or warranties relating to fitness for a particular purpose, merchantability, or infringement of any patent, copyright or other intellectual property right. In order to minimize risks associated with the customer's applications, adequate design and operating safeguards must be provided by the customer to minimize inherent or procedural hazards. Testing and other quality control techniques are utilized to the extent Orister deems necessary to support this warranty. Specific testing of all parameters of each device is not necessarily performed.

Orister and the Orister logo are trademarks of Orister Corporation. All other brand and product names appearing in this document are registered trademarks or trademarks of their respective holders.