

GAS GENERATOR SET

GS 100-6S

100 kWe / 60 Hz / Standby
208 - 600V



SYSTEM RATINGS

| Standby (NG) (LP) | GS 100N6SDT GS 100L6SDT | GS 100N6SGT GS 100L6SGT | GS 100N6SPT GS 100L6SPT | GS 100N6SJT GS 100L6SJT | GS 100N6SRT GS 100L6SRT | GS 100N6SNT GS 100L6SNT |
|----------------------|----------------------------|----------------------------|----------------------------|----------------------------|----------------------------|----------------------------|
| Voltage (L-L) | 240V** | 240V** | 208V** | 240V** | 480V** | 600V** |
| Phase | 1 | 1 | 3 | 3 | 3 | 3 |
| PF | 1 | 1 | 0.8 | 0.8 | 0.8 | 0.8 |
| Hz | 60 | 60 | 60 | 60 | 60 | 60 |
| Natural Gas | | | | | | |
| Ratings: Amps | 417 | 417 | 347 | 301 | 151 | 120 |
| Natural Gas | | | | | | |
| Ratings: kW/kVA | 100/100 | 100/100 | 100/125 | 100/125 | 100/125 | 100/125 |
| LP Gas | | | | | | |
| Ratings: Amps | 417 | 417 | 347 | 301 | 151 | 120 |
| LP Gas | | | | | | |
| Ratings: kW/kVA | 100/100 | 100/100 | 100/125 | 100/125 | 100/125 | 100/125 |
| skVA@30% | | | | | | |
| Voltage Dip | 311 | 130 | 258 | 258 | 344 | 277 |
| Generator Model* | 363CSL1617 | 431CSL6204 | 362CSL1606 | 362CSL1606 | 362CSL1606 | 362PSL1636 |
| Temp Rise | 130 °C/40 °C | 130 °C/40 °C | 130 °C/40 °C | 130 °C/40 °C | 130 °C/40 °C | 130 °C/40 °C |
| Connection | 4 LEAD | 12 LEAD ZIG-ZAG | 12 LEAD LOW WYE | 12 LEAD HI DELTA | 12 LEAD HI WYE | 4 LEAD WYE |

** UL 2200 Offered

Note: This unit is available with a dual fuel configuration.

CERTIFICATIONS AND STANDARDS

// **Generator set is designed and manufactured in facilities certified to standards ISO 9001:2008 and ISO 14001:2004**

// **Power Rating**

- Accepts Rated Load in One Step Per NFPA 110

// **UL 2200 / CSA – Optional**

- UL 2200 Listed
- CSA Certified

// **Performance Assurance Certification (PAC)**

- Generator Set Tested to ISO 8528-5 for Transient Response
- Verified product design, quality and performance integrity
- All engine systems are prototype and factory tested

STANDARD FEATURES*

- // MTU Onsite Energy is a single source supplier
 - // Global Product Support
 - // 2 Year Standard Warranty
 - // 6.8L Engine
 - 6.8 Liter Displacement
 - 4-Cycle
 - // 3-Way Catalyst
 - // Optional Fuels: LP Liquid and Dual Fuel
 - // Engine-generator resilient mounted
 - // Complete Range of Accessories
- // Generator
 - Brushless, Rotating Field Generator
 - 2/3 Pitch Windings
 - 300% Short Circuit Capability
 - // Digital Control Panel(s)
 - UL Recognized, CSA Certified, NFPA 110
 - Complete System Metering
 - LCD Display
 - // Cooling System
 - Integral Set-Mounted
 - Engine Driven Fan

STANDARD EQUIPMENT*

// Engine

Heavy Duty Air Cleaner
 Oil Pump
 Oil Drain Extension & S/O Valve
 Full Flow Oil Filter
 Jacket Water Pump
 Thermostat
 Blower Fan & Fan Drive
 Radiator - Unit Mounted
 Electric Starting Motor - 12V
 Governor - Electronic Isochronous
 Base - Formed Steel
 SAE Flywheel & Bell Housing
 Charging Alternator - 12V
 Battery Rack & Cables
 Flexible Exhaust Connection
 Liquid Cooled, Ball Bearing Turbocharger
 EPA Certified Engine

// Generator

NEMA MG1, IEEE and ANSI standards compliance for temperature rise and motor starting
 Sustained short circuit current of up to 300% of the rated current for up to 10 seconds
 Self-Ventilated
 Superior Voltage Waveform
 Solid State, Volts-per-Hertz Regulator
 ±1% Voltage Regulation No Load to Full Load

Brushless Alternator with Brushless Pilot Exciter
 4 Pole, Rotating Field
 130 °C Maximum Standby Temperature Rise
 1 Bearing, Sealed
 Flexible Coupling
 Full Amortisseur Windings
 125% Rotor Balancing
 3-Phase Voltage Sensing
 100% of Rated Load - One Step
 5% Maximum Total Harmonic Distortion

// Digital Control Panel(s)

Digital Metering
 Engine Parameters
 Generator Protection Functions
 Engine Protection
 SAE J1939 Engine ECU Communications
 Windows®-Based Software
 Multilingual Capability
 Remote Communications to RDP-110 Remote Annunciator
 16 Programmable Contact Inputs
 Up to 11 Contact Outputs
 UL Recognized, CSA Certified, CE Approved
 Event Recording
 IP 54 Front Panel Rating with Integrated Gasket
 NFPA110 Compatible

* Represents standard product only. Consult Factory/MTU Onsite Energy Distributor for additional configurations.

APPLICATION DATA

// Engine

| | |
|------------------------------------|--------------|
| Manufacturer | Ford |
| Model | 6.8L V10 |
| Type | 4-Cycle |
| Aspiration | Turbocharged |
| Arrangement | 10-V |
| Displacement: L (in ³) | 6.8 (415) |
| Bore: cm (in) | 90.2 (3.55) |
| Stroke: cm (in) | 105.8 (4.17) |
| Compression Ratio | 9:1 |
| Rated RPM | 1,800 |
| Engine Governor | Bosch |
| Maximum Power (NG): kWm (bhp) | 132 (177) |
| Maximum Power (LP): kWm (bhp) | 132 (177) |
| Speed Regulation | C/F |
| Air Cleaner | Dry |

// Liquid Capacity (Lubrication)

| | |
|---------------------------------------|--------------|
| Total Oil System: L (gal) | 5.7 (1.5) |
| Engine Jacket Water Capacity: L (gal) | 6 (1.6) |
| System Coolant Capacity: L (gal) | 27.47 (7.25) |

// Electrical

| | |
|------------------------------------------|-----|
| Electric Volts DC | 12 |
| Cold Cranking Amps Under -17.8 °C (0 °F) | 925 |

// Fuel Inlet

| | |
|------------------------------------------------------------------|----------------|
| Fuel Supply Connection Size | 1 1/2" NPT |
| Fuel Supply Pressure: mm H ₂ O (in. H ₂ O) | 178-279 (7-11) |

// Fuel Consumption (NG-1000 BTU/ft³ / LP-2500 BTU/ft³)

| | NG | LPG |
|-------------------------------------------------------------------|---------------|---------------|
| At 100% of Power Rating: m ³ /hr (ft ³ /hr) | 31.15 (1,100) | 14.49 (511.5) |
| At 75% of Power Rating: m ³ /hr (ft ³ /hr) | 23.67 (835.9) | 11.32 (400) |
| At 50% of Power Rating: m ³ /hr (ft ³ /hr) | 16.2 (520.1) | 8.07 (284.8) |

// Cooling - Radiator System

| | | |
|----------------------------------------------------------------------------------------------------|---------------|-----------|
| Ambient Capacity of Radiator: °C (°F) | 50 (122) | |
| Maximum Restriction of Cooling Air, Intake, and Discharge Side of Rad.: kPa (in. H ₂ O) | 0.12 (0.5) | |
| Water Pump Capacity: L/min (gpm) | 123 (32.5) | |
| Heat Rejection to Coolant: kW (BTUM) | 81.29 (4,623) | |
| Heat Radiated to Ambient: kW (BTUM) | 41.54 (2,362) | |
| Fan Power: kW (hp) | 4.1 (5.5) | 4.1 (5.5) |

// Air Requirements

| | |
|---------------------------------------------------------------------------------------------------------------------------------------------|-----------------|
| Aspirating: *m ³ /min (SCFM) | 5.91 (208.7) |
| Air Flow Required for Rad. Cooled Unit: *m ³ /min (SCFM) | 254.9 (9,001.7) |
| Remote Cooled Applications; Air Flow Required for Dissipation of Radiated Gen-set Heat For a Max of 25 °F Rise: *m ³ /min (SCFM) | 150.9 (5,329) |

* Air density = 1.184 kg/m³ (0.0739 lbm/ft³)

// Exhaust System

| | |
|-------------------------------------------------------------|---------------|
| Gas Temp. (Stack): °C (°F) | 716.1 (1,321) |
| Gas Volume at Stack Temp: m ³ /min (CFM) | 20.2 (713.4) |
| Maximum Allowable Back Pressure: kPa (in. H ₂ O) | 6.23 (25) |

WEIGHTS AND DIMENSIONS

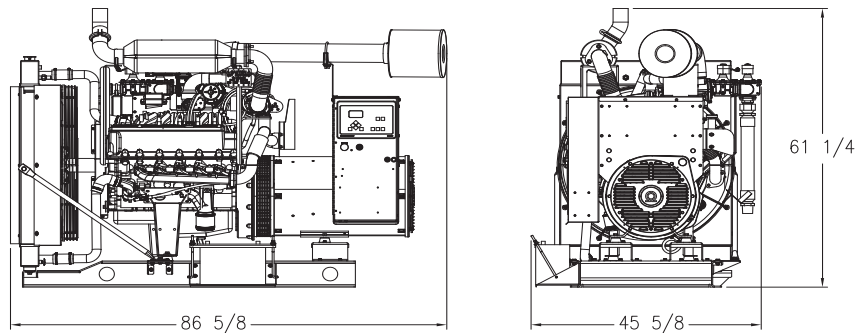

Drawing above for illustration purposes only, based on standard open power 480 volt generator set. Lengths may vary with other voltages. Do not use for installation design. See website for unit specific template drawings.

| System | Dimensions (L x W x H) | Weight (dry) |
|--------|---------------------------------------------------|-----------------------|
| OPU | 2,199 x 1,158 x 1,556 mm (86.6 x 45.6 x 61.25 in) | 1,163.9 kg (2,566 lb) |

Weights and dimensions are based on open power units and are estimates only. Consult the factory for accurate weights and dimensions for your specific generator set.

SOUND DATA

| Unit Type | Standby Full Load (NG) | Standby Full Load (LP) |
|--------------------------------|------------------------|------------------------|
| Level 0: Open Power Unit dB(A) | 77.2 | 77.3 |

Sound data is provided at 7 m (23 ft). Generator set tested in accordance with ISO 8528-10 and with infinite exhaust.

EMISSIONS DATA

| Fuel Type | THC + NO _x | CO |
|----------------|-----------------------|------|
| Natural Gas | 0.44 | 0.20 |
| Liquid Propane | 0.12 | 0.09 |

**All units are in g/hp-hr.
Engine meets EPA 40 CFR Part 60/1048 specifications.**

RATING DEFINITIONS AND CONDITIONS

// Standby ratings apply to installations served by a reliable utility source. The standby rating is applicable to varying loads for the duration of a power outage. No overload capability for this rating. Ratings are in accordance with ISO 3046-1, BS 5514, AS 2789, and DIN 6271.

// Deration Factor:

Altitude: Consult your local MTU Onsite Energy Power Generation Distributor for altitude derations.

Temperature: Consult your local MTU Onsite Energy Power Generation Distributor for temperature derations.

Materials and specifications subject to change without notice.

C/F = Consult Factory/MTU Onsite Energy Distributor

MTU Onsite Energy
A Rolls-Royce Power Systems Brand

www.mtuonsiteenergy.com