

Digilent PmodOD1™ Open Drain Output Module Board Reference Manual



Revision: February 23, 2007

Note: This document applies to REV A of the board.

215 E Main Suite D | Pullman, WA 99163
(509) 334 6306 Voice and Fax

Overview

The Digilent PmodOD1 Open Drain Output Module Board (PmodOD1) can drive high current devices using On-Semiconductor NTHD4508NT power FET output transistors. The output transistors are driven by logic signals from a Digilent system board.

The output transistors function as low side switches, sinking current from an external voltage source to ground. The outputs can be used to drive DC motors, stepper motors, relays, solenoids or other electrical devices operated via a switch closure to ground. Flyback protection diodes are included on each output to allow the outputs to drive inductive loads.

Features include:

- two NTHD4508 dual power FETs
- 4.1A peak output current ($t < 5s$)
- 3.0A continuous current (at 25°C), 2.2A continuous current (at 85°C)
- a 6-pin header for inputs
- two screw terminal blocks for outputs
- 20V max. output voltage
- small form factor (0.80" x 1.15").

Functional Description

The PmodOD1 module is designed to work with either Digilent programmable logic system boards or embedded control boards. Most Digilent system boards, like the Basys, Nexys or Cerebot, have 6-pin connectors that allow the PmodOD1 to plug directly into the system board or to connect via a Digilent 6-pin cable.

Some older Digilent boards may need a Digilent Module Interface Board (MIB) and a 6-pin cable to connect to the PmodOD1. The

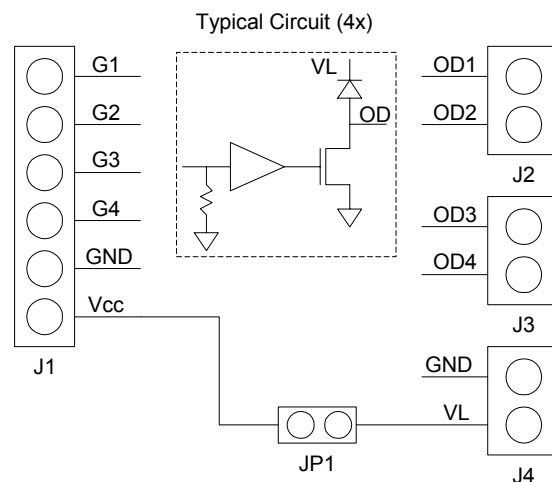
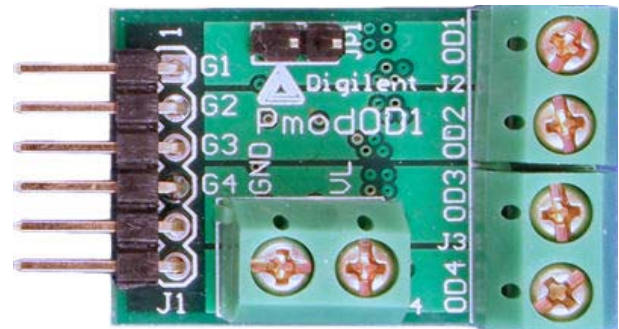

Figure 1 PmodOD1 Block Diagram

MIB plugs into the system board and the cable connects the MIB to the PmodOD1.

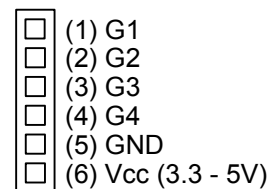

Figure 2 PmodOD1 Input Connector, J1

The PmodOD1 provides four logic level inputs, G1-G4. Each input connects to a Schmitt trigger, non-inverting buffer that drives the gate of the corresponding output transistor. Driving an input high will drive the gate of the corresponding output transistor high,

turning the transistor on. The output transistor will then sink current to ground. Driving an input low drives the gate of the transistor low, turning off the output transistor. Each input has a pull-down resistor that prevents the output from turning on unless it is actively being driven high.

Access to the outputs of the PmodOD1 is provided by screw terminal blocks J2 and J3. The outputs are labeled OD1 – OD4. Input G1 controls output OD1 and so on. Each output is connected to the drain of the corresponding output transistor and functions like a low impedance switch closure to ground.

Each output provides a clamp diode to prevent damage due to flyback voltages generated by inductive loads. Each output transistor functions independently of the others, so they can be used individually or simultaneously.

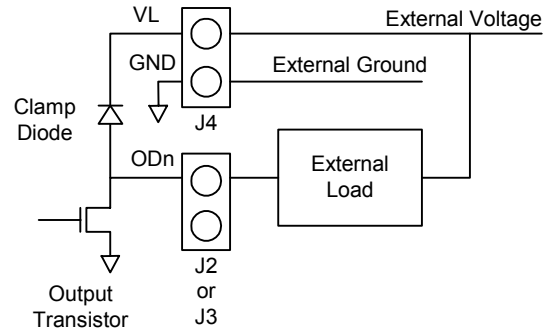

Figure 3 Output Circuit with Load Connection

As illustrated in Figure 3, a load is connected so that current from an external voltage source conducts through the load to ground when the output transistor is turned on. In order to complete the circuit, the GND pin on J4 must be connected to the ground for the external voltage supply. Additionally, the external voltage source must be connected to the VL pin on J4 to complete the circuit for the output clamp diode.

For more information, the PmodOD1 schematic is available at www.digilentinc.com.