

THIS DRAWING IS UNPUBLISHED. RELEASED FOR PUBLICATION
 © COPYRIGHT 2005 BY TYCO ELECTRONICS CORPORATION. ALL RIGHTS RESERVED.

LOC		DIST		REVISIONS			
P	LTR	DESCRIPTION	DATE	DWN	APVD		
GP	00						
	C	REVISED PER ECO-10-000073	4FEB2010	CJV	SB		

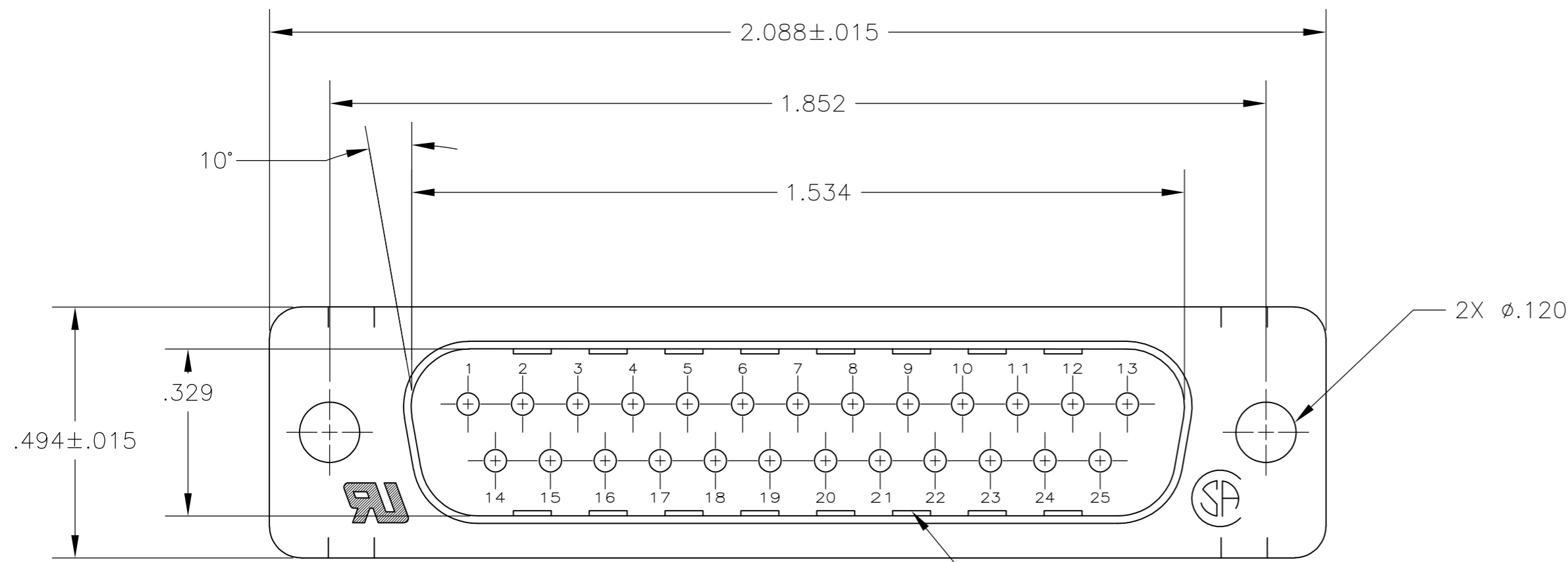

- 1 MOLDED PARTS: GLASS-FILLED NYLON, UL 94V-0 RATED, COLOR BLACK.
SHELLS: CARBON STEEL.
CONTACTS: BRASS.
- 2 SHELLS: .000200 MIN TIN OVER .000100 MIN COPPER.
CONTACTS: GOLD PLATING FOR A LENGTH OF .150 MIN FROM MATING END, .000030 MIN GOLD IN MATED AREA, .000100 MIN TIN ON SOLDER END, BOTH OVER .000050 MIN NICKEL.
-OR-
GOLD FLASH OVER PALLADIUM-NICKEL PLATED FOR A LENGTH OF .150 MIN FROM MATING END, .000030 MIN TOTAL IN MATED AREA, .000100 MIN TIN ON SOLDER END, BOTH OVER .000050 MIN NICKEL.

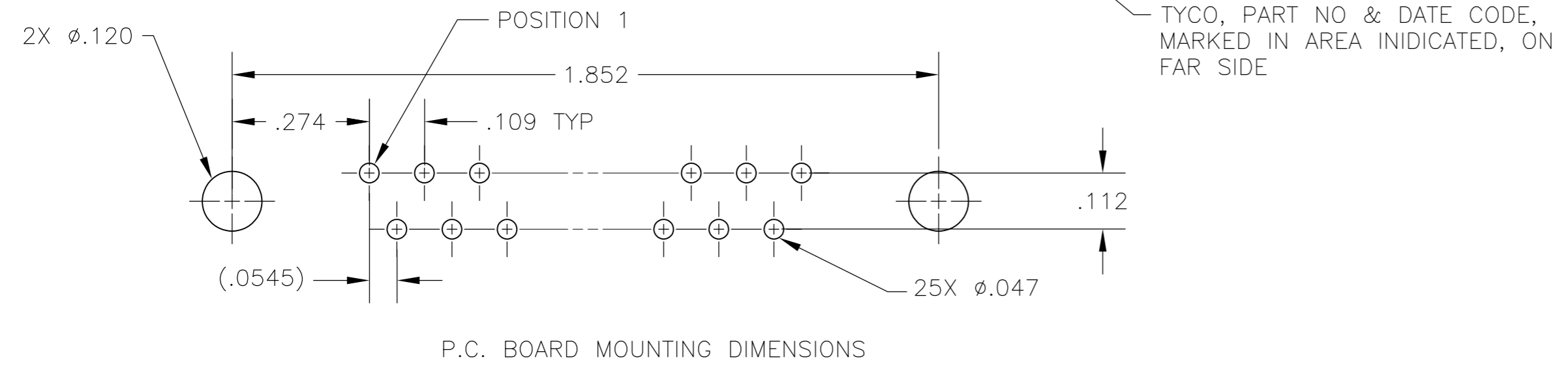
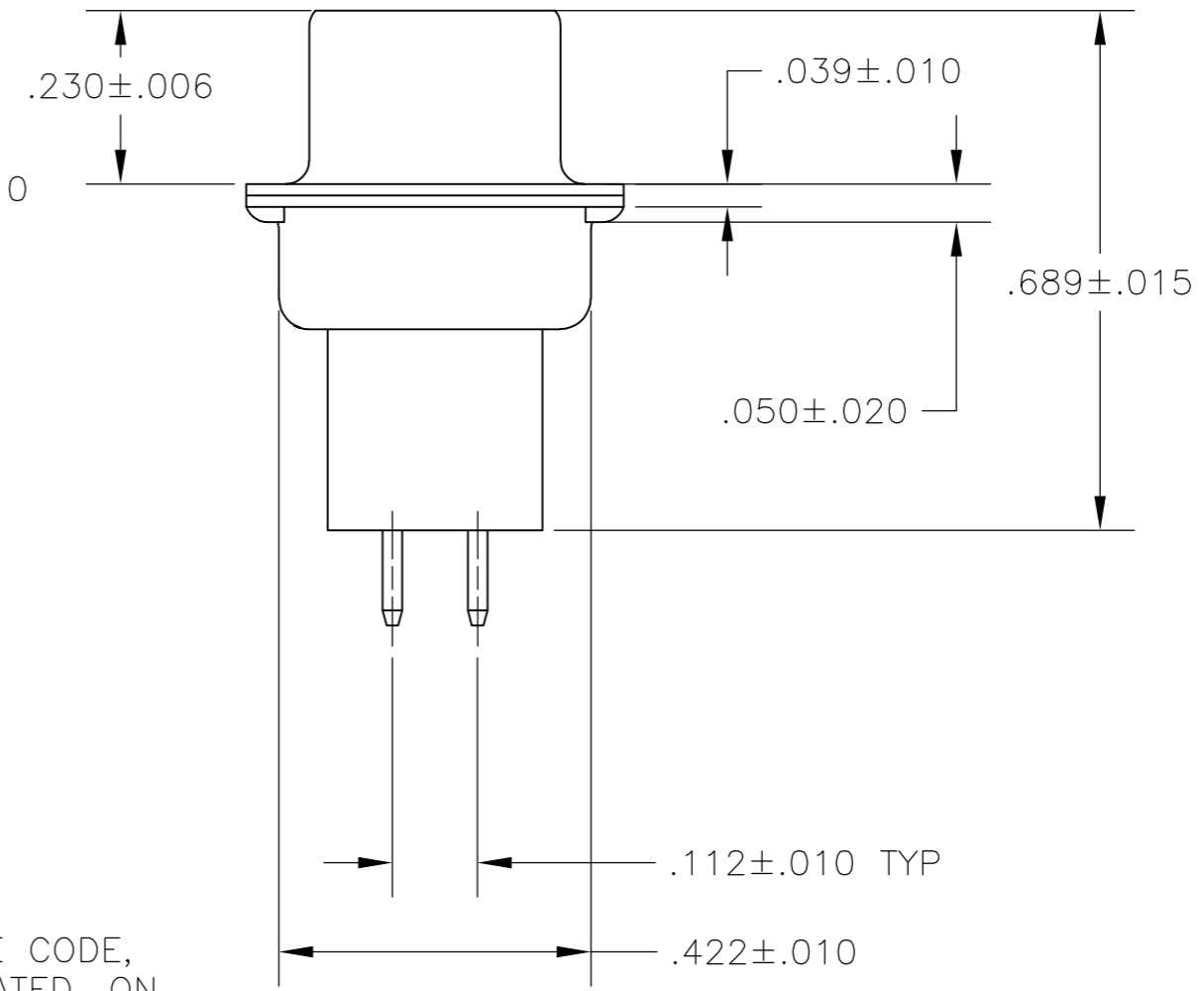
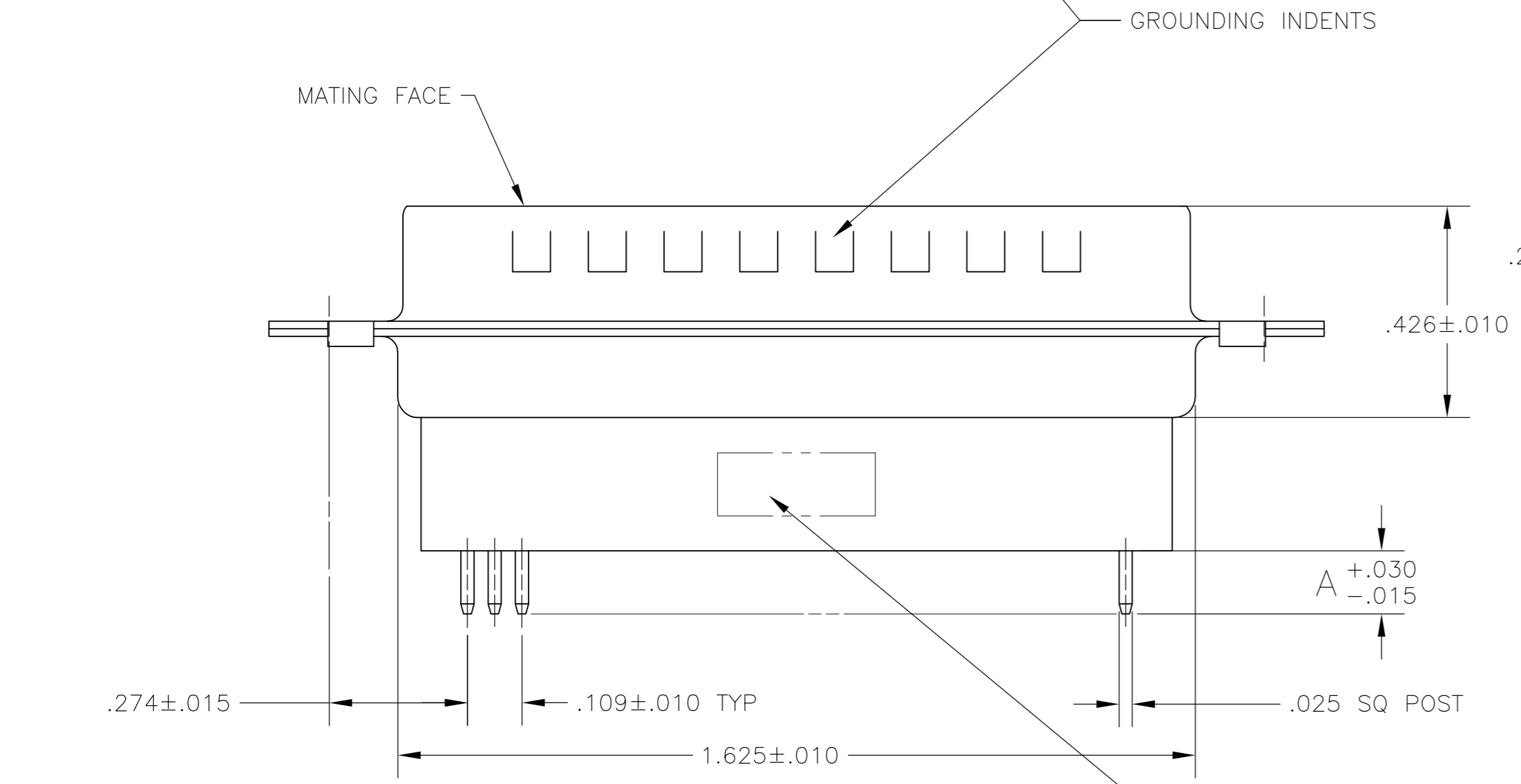

TYCO, PART NO & DATE CODE, MARKED IN AREA INDICATED, ON FAR SIDE

.188	5745412-7
.125	5745412-1
A	PART NO

THIS DRAWING IS A CONTROLLED DOCUMENT.		DWN B. LATTUCA 16SEPT05	Tyco Electronics Corporation Harrisburg, PA 17105-3608	
DIMENSIONS: INCHES		CHK S. BOLASH 16SEPT05	NAME	
TOLERANCES UNLESS OTHERWISE SPECIFIED:		APVD M. WALMSLEY 16SEPT05	PLUG ASSEMBLY, SIZE 3, 25 POSN, VERTICAL, .025 SQ. POSTS, GROUNDING INDENTS, AMPLIMITE HDP	
0 PLC ± -		PRODUCT SPEC 108-40025	SIZE A2	CAGE CODE 00779
1 PLC ± -		APPLICATION SPEC 114-40013	DRAWING NO C=5745412	RESTRICTED TO -
2 PLC ± -			SCALE NTS	SHEET 1 of 1
3 PLC ± .005				REV C
4 PLC ± -				
ANGLES ± -				
FINISH				
MATERIAL 1				
FINISH 2				
CUSTOMER DRAWING				

5745412