

Features

Type	$R_{DS(on)}$	I_{OUT}	V_{CC}
VN800PS-E	135 m Ω	0.7 A	36 V

- ECOPACK[®]: lead free and RoHS compliant
- Automotive Grade: compliance with AEC guidelines
- Very low standby current
- CMOS compatible input
- Thermal shutdown protection and diagnosis
- Undervoltage shutdown
- Overvoltage clamp
- Load current limitation
- Reverse battery protection
- Electrostatic discharge protection

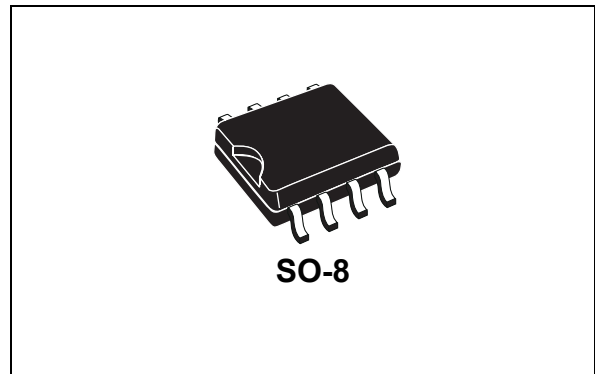

Description

The VN800PS-E is monolithic device made by using STMicroelectronics[™] VIPower[™] M0-3 technology, intended for driving any kind of load with one side connected to ground.

Active V_{CC} pin voltage clamp protects the device against low energy spikes. Active current limitation combined with thermal shutdown and automatic restart protect the device against overload. Device automatically turns off in case of ground pin disconnection.

This device is especially suitable for industrial applications in norms conformity with IEC1131 (Programmable Controllers International Standard).

Table 1. Device summary

Package	Order codes	
	Tube	Tape and reel
SO-8	VN800PS-E	VN800PSTR-E

Contents

1	Block diagram and pin description	5
2	Electrical specifications	6
2.1	Absolute maximum ratings	6
2.2	Thermal data	7
2.3	Electrical characteristics	8
3	Application information	15
3.1	GND protection network against reverse battery	15
3.1.1	Solution 1: resistor in the ground line (RGND only)	15
3.1.2	Solution 2: diode (DGND) in the ground line	16
3.2	Microcontroller I/Os protection	16
3.3	Electrical characteristics curves	17
3.4	SO-8 maximum demagnetization energy	19
4	Package and PCB thermal data	20
4.1	SO-8 thermal data	20
5	Package and packing information	23
5.1	ECOPACK®	23
5.2	SO-8 package information	23
5.3	SO-8 packing information	25
6	Revision history	26

List of tables

Table 1.	Device summary	1
Table 2.	Suggested connections for unused and not connected pins	5
Table 3.	Absolute maximum ratings	6
Table 4.	Thermal data.	7
Table 5.	Power	8
Table 6.	Switching ($V_{CC} = 24\text{ V}$).	8
Table 7.	Input pin	8
Table 8.	V_{CC} - output diode	9
Table 9.	Status pin	9
Table 10.	Protections	9
Table 11.	Truth table.	10
Table 12.	Electrical transient requirements on V_{CC} pin (part 1/3).	12
Table 13.	Electrical transient requirements on V_{CC} pin (part 2/3).	12
Table 14.	Electrical transient requirements on V_{CC} pin (part 3/3).	12
Table 15.	Thermal parameter	22
Table 16.	SO-8 mechanical data	23
Table 17.	Document revision history	26

List of figures

Figure 1.	Block diagram	5
Figure 2.	Configuration diagram (top view)	5
Figure 3.	Current and voltage conventions	6
Figure 4.	Status timing	10
Figure 5.	Switching time waveforms	11
Figure 6.	Peak short circuit current test circuit	13
Figure 7.	Avalanche energy test circuit	13
Figure 8.	Waveforms	14
Figure 9.	Application schematic	15
Figure 10.	Off-state output current	17
Figure 11.	High level input current	17
Figure 12.	Status leakage current	17
Figure 13.	On-state resistance vs T_{case}	17
Figure 14.	On-state resistance vs V_{CC}	17
Figure 15.	Input high level	17
Figure 16.	Input low level	18
Figure 17.	Turn-on voltage slope	18
Figure 18.	Overvoltage shutdown	18
Figure 19.	Input hysteresis voltage	18
Figure 20.	Turn-off voltage slope	18
Figure 21.	I_{LIM} vs T_{case}	18
Figure 22.	SO-8 maximum turn off current versus load inductance	19
Figure 23.	Demagnetization	19
Figure 24.	SO-8 PC board ⁽¹⁾	20
Figure 25.	SO-8 $R_{thj-amb}$ vs PCB copper area in open box free air condition	20
Figure 26.	SO-8 thermal impedance junction ambient single pulse	21
Figure 27.	Thermal fitting model of a single channel HSD in SO-8	21
Figure 28.	SO-8 package dimensions	24
Figure 29.	SO-8 tube shipment (no suffix)	25
Figure 30.	SO-8 tape and reel shipment (suffix "TR")	25

1 Block diagram and pin description

Figure 1. Block diagram

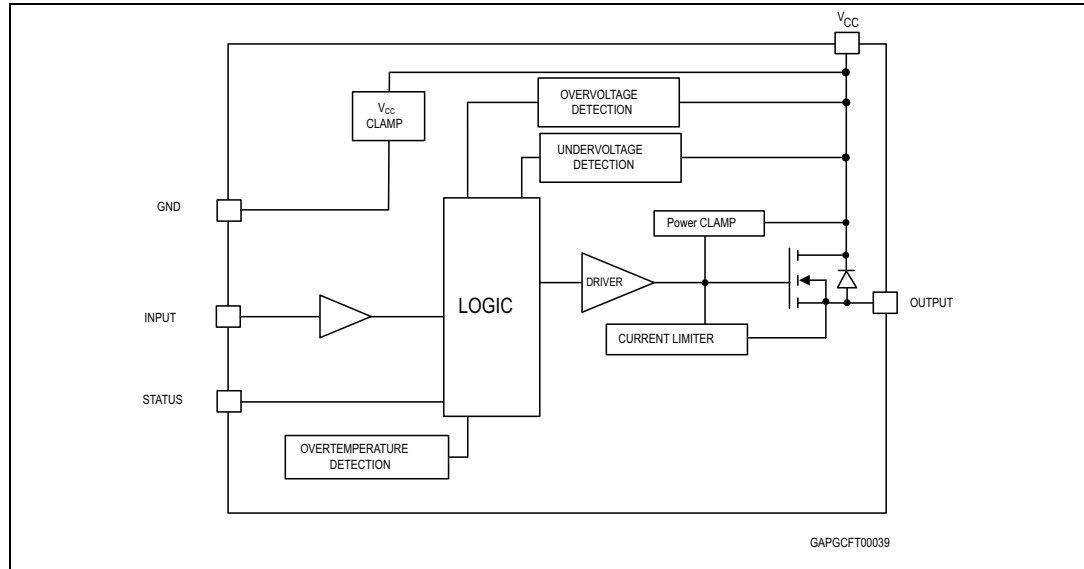

Figure 2. Configuration diagram (top view)

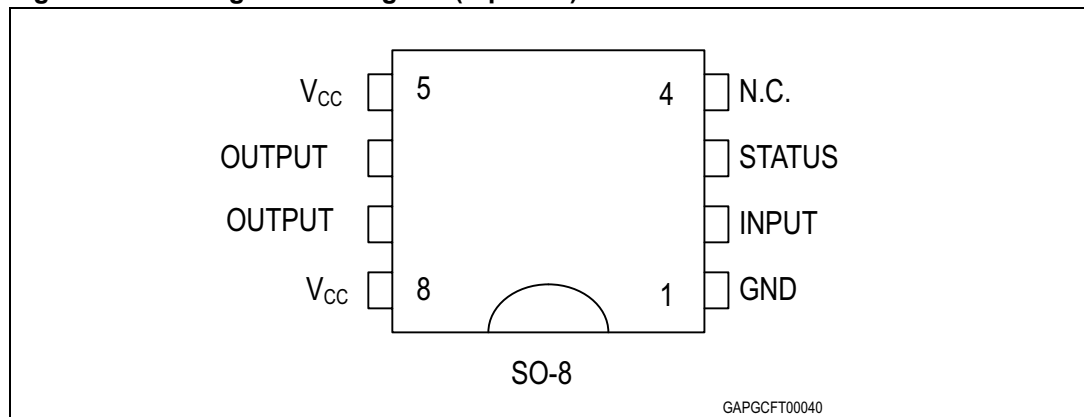
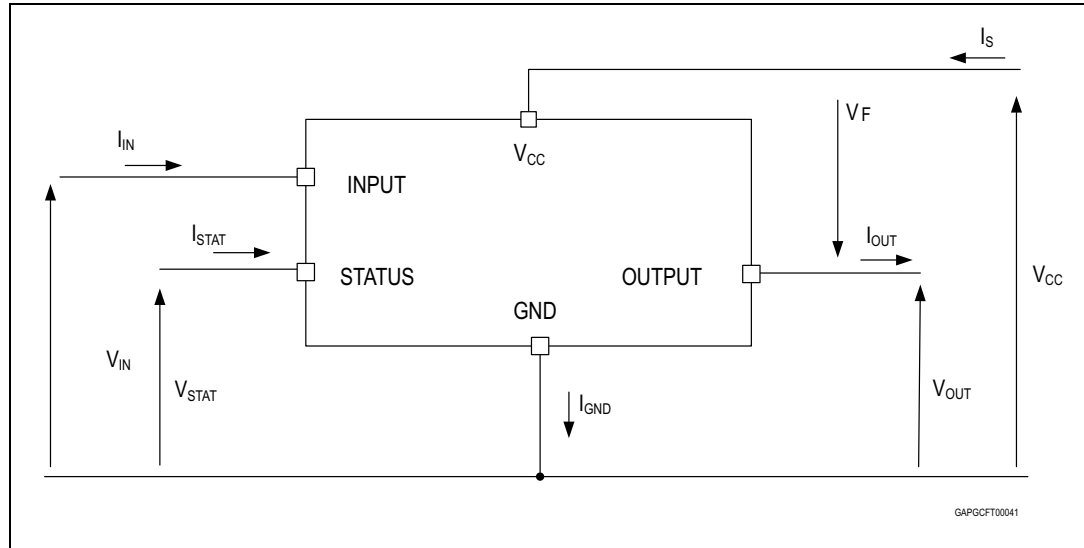

Table 2. Suggested connections for unused and not connected pins

Connection/pin	Status	N.C.	Output	Input
Floating	X	X	X	X
To ground		X		Through 10 KΩ resistor

2 Electrical specifications

Figure 3. Current and voltage conventions



2.1 Absolute maximum ratings

Table 3. Absolute maximum ratings

Symbol	Parameter	Value	Unit
		SO-8	
V_{CC}	DC supply voltage	41	V
$-V_{CC}$	Reverse DC supply voltage	-0.3	V
$-I_{GND}$	DC reverse ground pin current	-200	mA
I_{OUT}	DC output current	Internally limited	A
$-I_{OUT}$	Reverse DC output current	-6	A
I_{IN}	DC input current	+/- 10	mA
V_{IN}	Input voltage range	-3/+ V_{CC}	V
V_{STAT}	DC status voltage	+ V_{CC}	V
V_{ESD}	Electrostatic discharge (human body model: R = 1.5 K Ω ; C = 100 pF)		
	- Input	4000	V
	- Status	4000	V
	- Output	5000	V
	- V_{CC}	5000	V
P_{tot}	Power dissipation $T_C = 25\text{ }^\circ\text{C}$	4.2	W
E_{MAX}	Maximum switching energy (L = 77.5 mH; $R_L = 0\text{ }\Omega$; $V_{bat} = 13.5\text{ V}$; $T_{jstart} = 150\text{ }^\circ\text{C}$; $I_L = 1.5\text{ A}$)	121	mJ

Table 3. Absolute maximum ratings (continued)

Symbol	Parameter	Value	Unit
		SO-8	
T_j	Junction operating temperature	Internally limited	°C
T_c	Case operating temperature	-40 to 150	°C
T_{stg}	Storage temperature	-55 to 150	°C

2.2 Thermal data

Table 4. Thermal data

Symbol	Parameter	Value	Unit
		SO-8	
$R_{thj-lead}$	Thermal resistance junction-lead max	30	°C/W
$R_{thj-amb}$	Thermal resistance junction-ambient max	93 ⁽¹⁾	°C/W
		82 ⁽²⁾	°C/W

1. When mounted on FR4 printed circuit board with 0.5 cm² of copper area (at least 35 μm thick) connected to all V_{CC} pins.
2. When mounted on FR4 printed circuit board with 2 cm² of copper area (at least 35 μm thick).

2.3 Electrical characteristics

Values specified in this section are for $8\text{ V} < V_{CC} < 36\text{ V}$; $-40\text{ }^{\circ}\text{C} < T_j < 150\text{ }^{\circ}\text{C}$, unless otherwise stated.

Table 5. Power

Symbol	Parameter	Test conditions	Min.	Typ.	Max.	Unit
V_{CC}	Operating supply voltage		5.5		36	V
V_{USD}	Undervoltage shutdown		3	4	5.5	V
V_{OV}	Overvoltage shutdown		36	42		V
R_{ON}	On-state resistance	$I_{OUT} = 0.5\text{ A}$; $T_j = 25\text{ }^{\circ}\text{C}$ $I_{OUT} = 0.5\text{ A}$			135 270	m Ω m Ω
I_S	Supply current	Off-state; $V_{CC} = 24\text{ V}$; $T_{case} = 25\text{ }^{\circ}\text{C}$ On-state; $V_{CC} = 24\text{ V}$ On-state; $V_{CC} = 24\text{ V}$; $T_{case} = 100\text{ }^{\circ}\text{C}$		10 1.5	20 3.5 2.6	μA mA mA
I_{LGND}	Output current at turn-off	$V_{CC} = V_{STAT} = V_{IN} = V_{GND} = 24\text{ V}$; $V_{OUT} = 0\text{ V}$			1	mA
$I_{L(off1)}$	Off-state output current	$V_{IN} = V_{OUT} = 0\text{ V}$	0		50	μA
$I_{L(off2)}$	Off-state output current	$V_{IN} = V_{OUT} = 0\text{ V}$; $V_{CC} = 13\text{ V}$; $T_j = 125\text{ }^{\circ}\text{C}$			5	μA
$I_{L(off3)}$	Off-state output current	$V_{IN} = V_{OUT} = 0\text{ V}$; $V_{CC} = 13\text{ V}$; $T_j = 25\text{ }^{\circ}\text{C}$			3	μA

Table 6. Switching ($V_{CC} = 24\text{ V}$)

Symbol	Parameter	Test conditions	Min.	Typ.	Max.	Unit
$t_{d(on)}$	Turn-on delay time	$R_L = 48\text{ }\Omega$ from V_{IN} rising edge to $V_{OUT} = 2.4\text{ V}$	-	10	-	μs
$t_{d(off)}$	Turn-off delay time	$R_L = 48\text{ }\Omega$ from V_{IN} falling edge to $V_{OUT} = 21.6\text{ V}$	-	40	-	μs
$dV_{OUT}/dt_{(on)}$	Turn-on voltage slope	$R_L = 48\text{ }\Omega$ from $V_{OUT} = 2.4\text{ V}$ to $V_{OUT} = 19.2\text{ V}$	-	See relative diagram	-	V/ μs
$dV_{OUT}/dt_{(off)}$	Turn-off voltage slope	$R_L = 48\text{ }\Omega$ from $V_{OUT} = 21.6\text{ V}$ to $V_{OUT} = 2.4\text{ V}$	-	See relative diagram	-	V/ μs

Table 7. Input pin

Symbol	Parameter	Test conditions	Min.	Typ.	Max.	Unit
V_{INL}	Input low level			-	1.25	V
I_{INL}	Low level input current	$V_{IN} = 1.25\text{ V}$	1	-		μA
V_{INH}	Input high level		3.25	-		V

Table 7. Input pin (continued)

Symbol	Parameter	Test conditions	Min.	Typ.	Max.	Unit
I_{INH}	High level input current	$V_{IN}=3.25\text{ V}$		-	10	μA
$V_{I(hyst)}$	Input hysteresis voltage		0.5	-		V
I_{IN}	Input current	$V_{IN} = V_{CC} = 36\text{ V}$		-	200	μA

Table 8. V_{CC} - output diode

Symbol	Parameter	Test conditions	Min.	Typ.	Max.	Unit
V_F	Forward on voltage	$-I_{OUT} = 0.6\text{ A}; T_j = 150\text{ }^\circ\text{C}$	-	-	0.6	V

Table 9. Status pin

Symbol	Parameter	Test conditions	Min.	Typ.	Max.	Unit
V_{STAT}	Status low output voltage	$I_{STAT} = 1.6\text{ mA}$	-	-	0.5	V
I_{LSTAT}	Status leakage current	Normal operation; $V_{STAT} = V_{CC} = 36\text{ V}$	-	-	10	μA
C_{STAT}	Status pin input capacitance	Normal operation; $V_{STAT} = 5\text{ V}$	-	-	30	pF

Table 10. Protections⁽¹⁾

Symbol	Parameter	Test conditions	Min.	Typ.	Max.	Unit
T_{TSD}	Shutdown temperature		150	175	200	$^\circ\text{C}$
T_R	Reset temperature		135			$^\circ\text{C}$
T_{hyst}	Thermal hysteresis		7	15		$^\circ\text{C}$
T_{SDL}	Status delay in overload condition	$T_j > T_{jsh}$			20	μs
I_{lim}	DC short circuit current	$V_{CC} = 24\text{ V}; R_{LOAD} = 10\text{ m}\Omega$	0.7		2	A
V_{demag}	Turn-off output clamp voltage	$I_{OUT} = 0.5\text{ A}; L = 6\text{ mH}$	$V_{CC} - 47$	$V_{CC} - 52$	$V_{CC} - 57$	V

1. To ensure long term reliability under heavy overload or short circuit conditions, protection and related diagnostic signals must be used together with a proper software strategy. If the device is subjected to abnormal conditions, this software must limit the duration and number of activation cycles.

Figure 4. Status timing

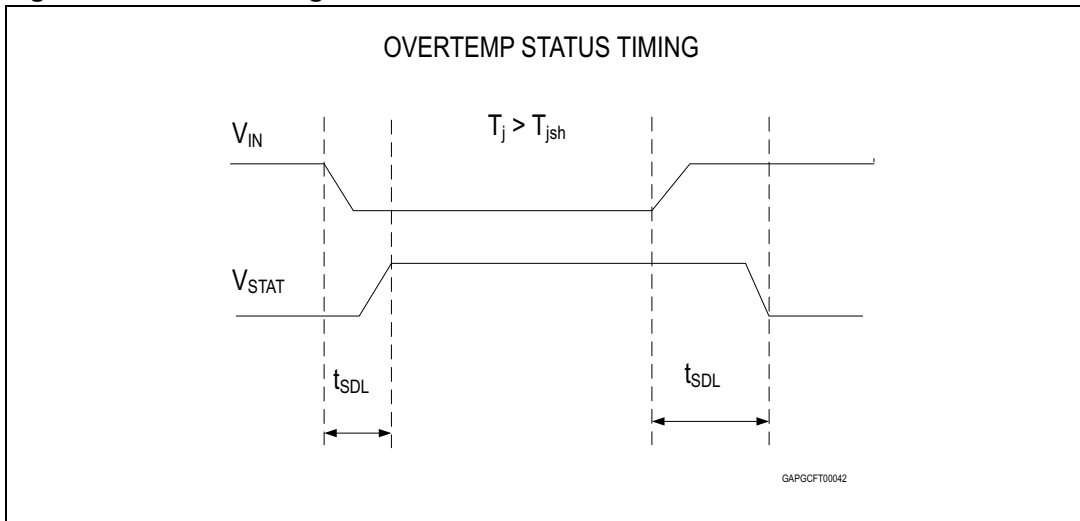

Table 11. Truth table

Conditions	Input	Output	Status
Normal operation	L	L	H
	H	H	H
Current limitation	L	L	H
	H	X	($T_j < T_{TSD}$) H
	H	X	($T_j > T_{TSD}$) L
Over temperature	L	L	H
	H	L	L
Undervoltage	L	L	X
	H	L	X
Overvoltage	L	L	H
	H	L	H

Figure 5. Switching time waveforms

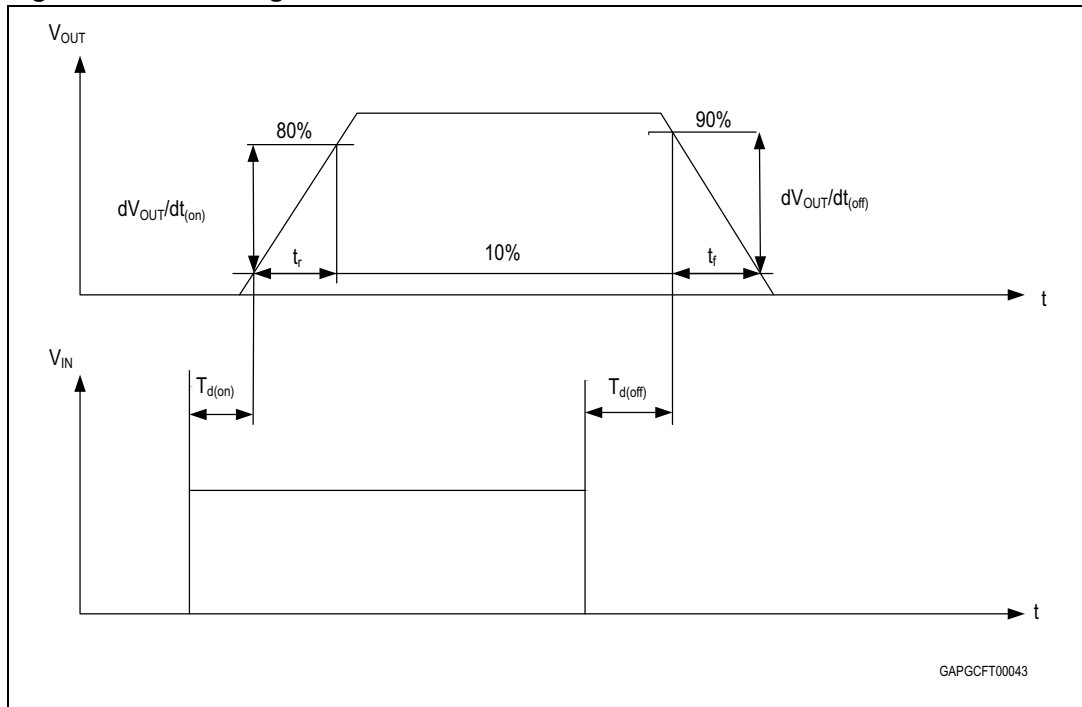

Table 12. Electrical transient requirements on V_{CC} pin (part 1/3)

ISO T/R 7637/1 test pulse	Test levels				Delays and impedance
	I	II	III	IV	
1	-25 V	-50 V	-75 V	-100 V	2 ms, 10 Ω
2	+25 V	+50 V	+75 V	+100 V	0.2 ms, 10 Ω
3a	-25 V	-50 V	-100 V	-150 V	0.1 μs, 50 Ω
3b	+25 V	+50 V	+75 V	+100 V	0.1 μs, 50 Ω
4	-4 V	-5 V	-6 V	-7 V	100 ms, 0.01 Ω
5	+26.5 V	+46.5 V	+66.5 V	+86.5 V	400 ms, 2 Ω

Table 13. Electrical transient requirements on V_{CC} pin (part 2/3)

ISO T/R 7637/1 Test pulse	Test levels results			
	I	II	III	IV
1	C	C	C	C
2	C	C	C	C
3a	C	C	C	C
3b	C	C	C	C
4	C	C	C	C
5	C	E	E	E

Table 14. Electrical transient requirements on V_{CC} pin (part 3/3)

Class	Contents
C	All functions of the device are performed as designed after exposure to disturbance.
E	One or more functions of the device is not performed as designed after exposure to disturbance and cannot be returned to proper operation without replacing the device.

Figure 6. Peak short circuit current test circuit

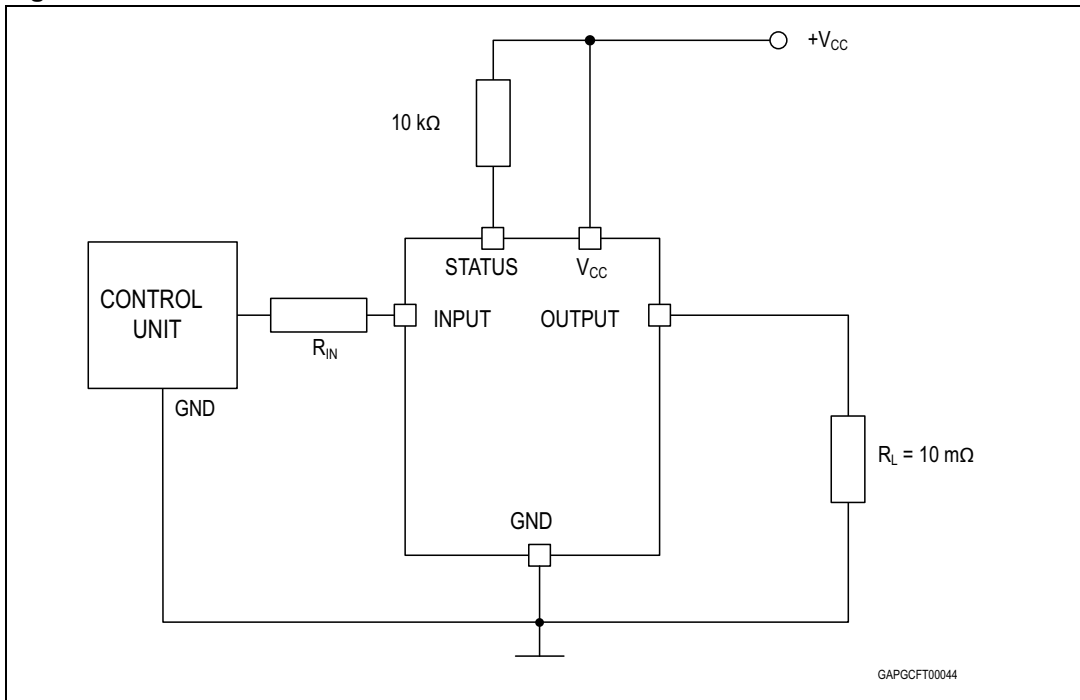

Figure 7. Avalanche energy test circuit

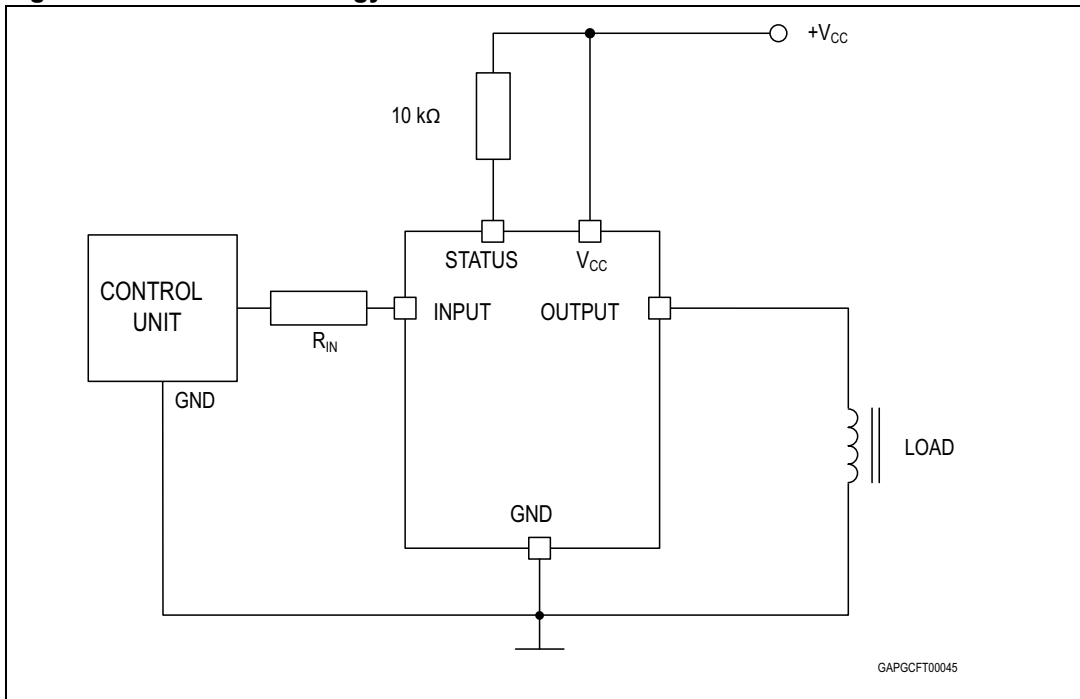
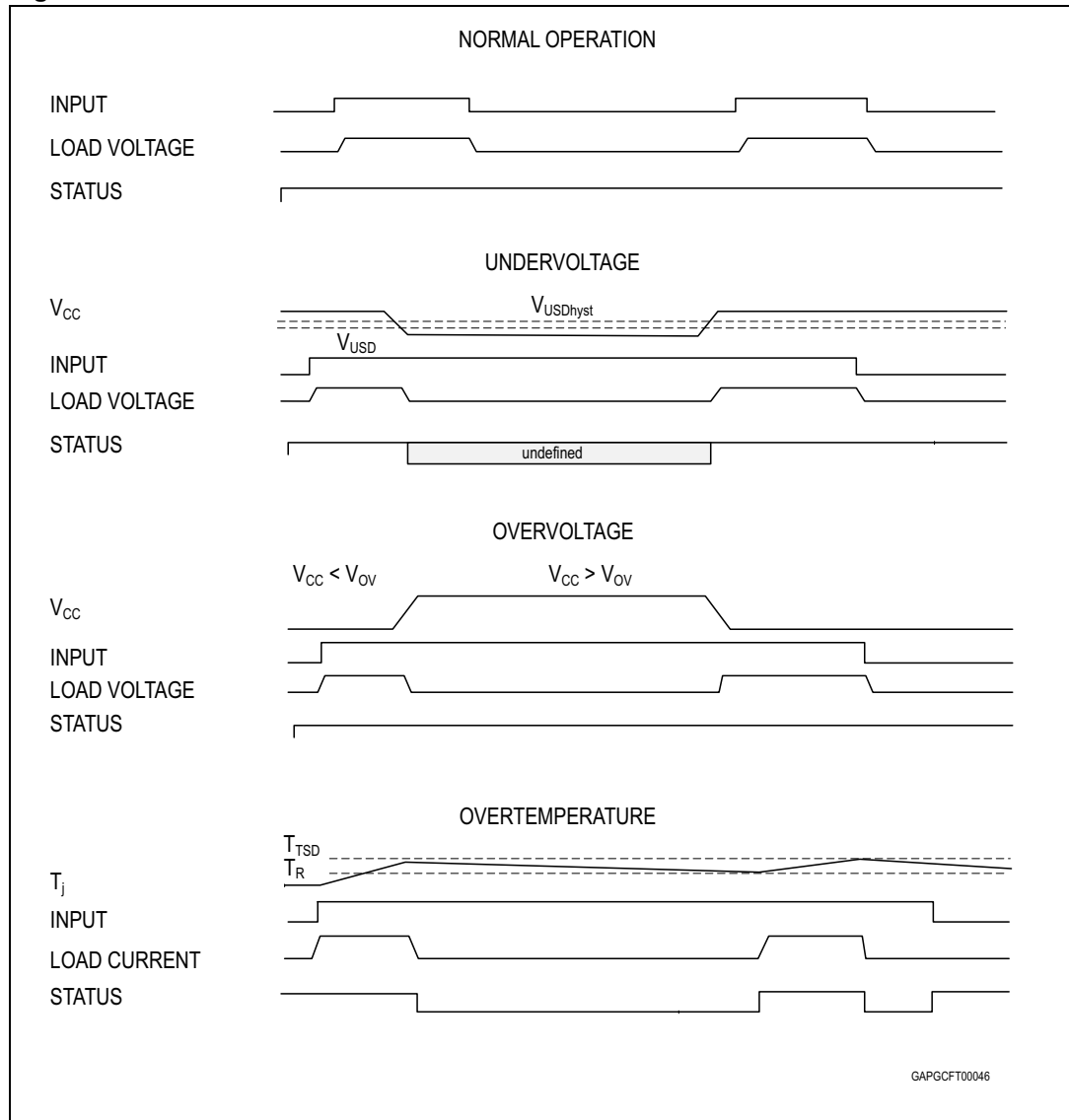
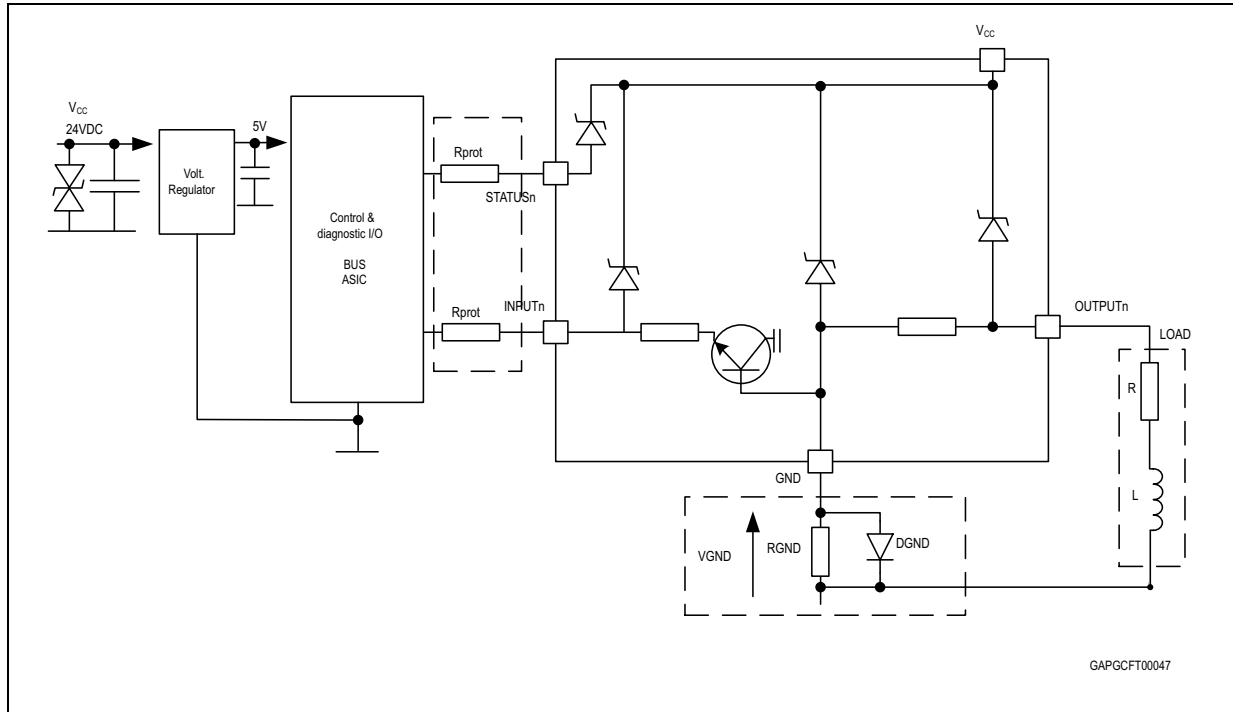

Figure 8. Waveforms



3 Application information

Figure 9. Application schematic



3.1 GND protection network against reverse battery

3.1.1 Solution 1: resistor in the ground line (R_{GND} only)

This can be used with any type of load.

The following is an indication on how to dimension the R_{GND} resistor.

$$1) R_{GND} \leq 600 \text{ mV} / (I_{S(on)max})$$

$$2) R_{GND} \geq (-V_{CC}) / (-I_{GND})$$

where -I_{GND} is the DC reverse ground pin current and can be found in the absolute maximum rating section of the device's datasheet.

Power dissipation in R_{GND} (when V_{CC} < 0: during reverse battery situations) is:

$$P_D = (-V_{CC})^2 / R_{GND}$$

This resistor can be shared amongst several different HSD. Please note that the value of this resistor should be calculated with formula (1) where I_{S(on)max} becomes the sum of the maximum on-state currents of the different devices.

Please note that if the microprocessor ground is not common with the device ground then the R_{GND} produces a shift (I_{S(on)max} * R_{GND}) in the input thresholds and the status output values. This shift varies depending on many devices are on in the case of several high side drivers sharing the same R_{GND}.

If the calculated power dissipation leads to a large resistor or several devices have to share the same resistor then the ST suggests to utilize Solution 2 (see [Section 3.1.2](#)).

3.1.2 Solution 2: diode (D_{GND}) in the ground line

A resistor ($R_{GND} = 1 \text{ k}\Omega$) should be inserted in parallel to D_{GND} if the device is driving an inductive load.

This small signal diode can be safely shared amongst several different HSD. Also in this case, the presence of the ground network produces a shift ($\approx 600 \text{ mV}$) in the input threshold and the status output values if the microprocessor ground is not common with the device ground. This shift not varies if more than one HSD shares the same diode/resistor network.

Series resistor in input and status lines are also required to prevent that, during battery voltage transient, the current exceeds the absolute maximum rating.

Safest configuration for unused input and status pin is to leave them unconnected.

3.2 Microcontroller I/Os protection

If a ground protection network is used and negative transients are present on the V_{CC} line, the control pins are pulled negative. ST suggests to insert a resistor (R_{prot}) in line to prevent the microcontroller I/Os pins to latch-up.

The value of these resistors is a compromise between the leakage current of microcontroller and the current required by the HSD I/Os (Input levels compatibility) with the latch-up limit of microcontroller I/Os.

$$-V_{CCpeak}/I_{latchup} \leq R_{prot} \leq (V_{OH\mu C} - V_{IH} - V_{GND}) / I_{IHmax}$$

Calculation example:

$$\text{For } V_{CCpeak} = -100 \text{ V and } I_{latchup} \geq 20 \text{ mA; } V_{OH\mu C} \geq 4.5 \text{ V}$$

$$5 \text{ k}\Omega \leq R_{prot} \leq 65 \text{ k}\Omega.$$

Recommended R_{prot} value is 10 k Ω .

3.3 Electrical characteristics curves

Figure 10. Off-state output current

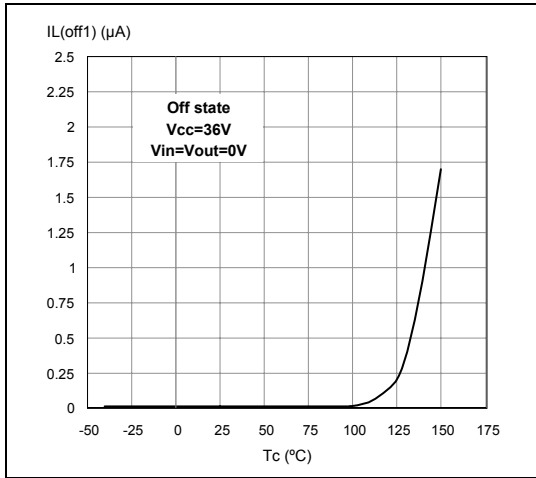

Figure 11. High level input current

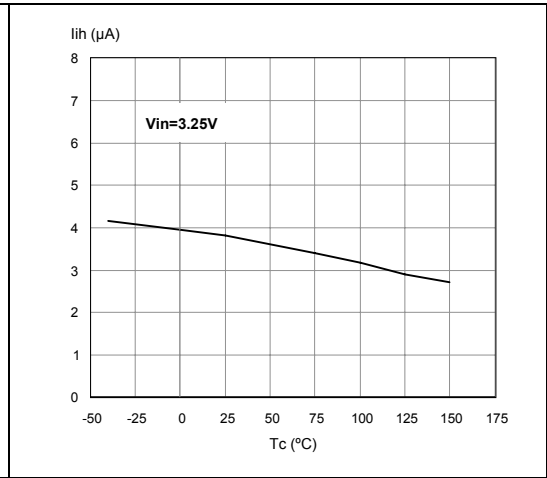

Figure 12. Status leakage current

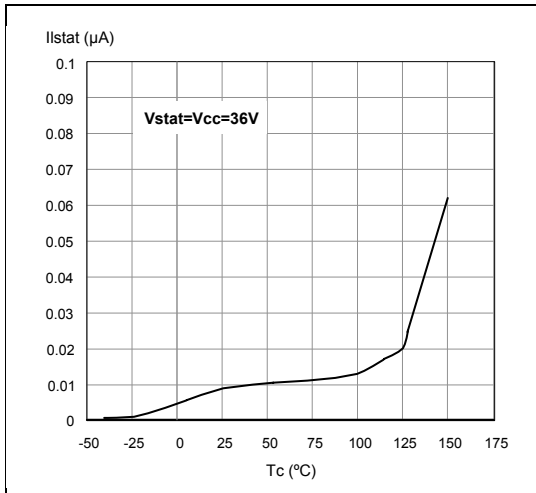

Figure 13. On-state resistance vs T_{case}

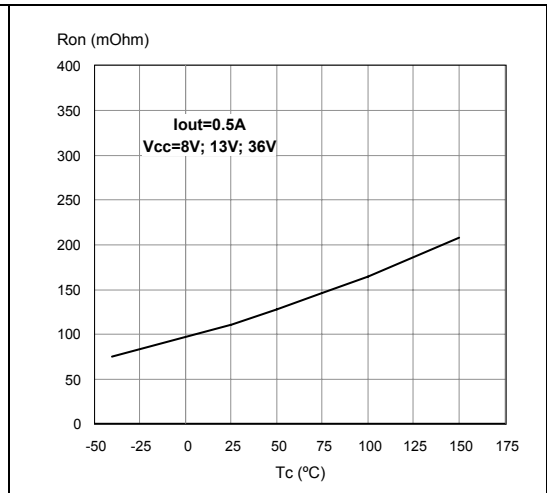

Figure 14. On-state resistance vs V_{CC}

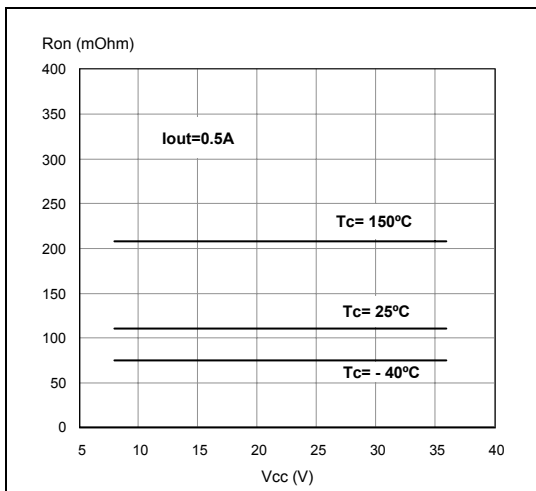

Figure 15. Input high level

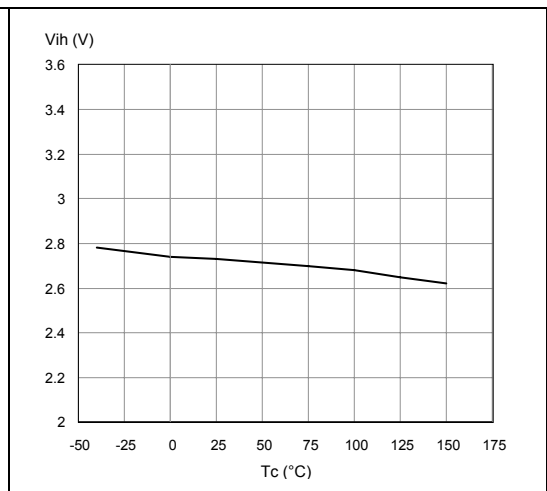

Figure 16. Input low level

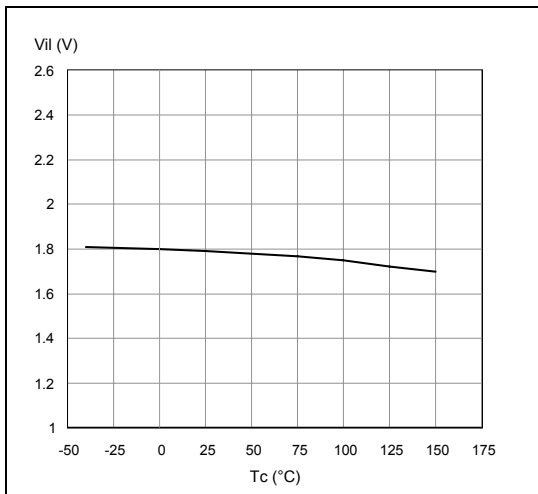

Figure 17. Turn-on voltage slope

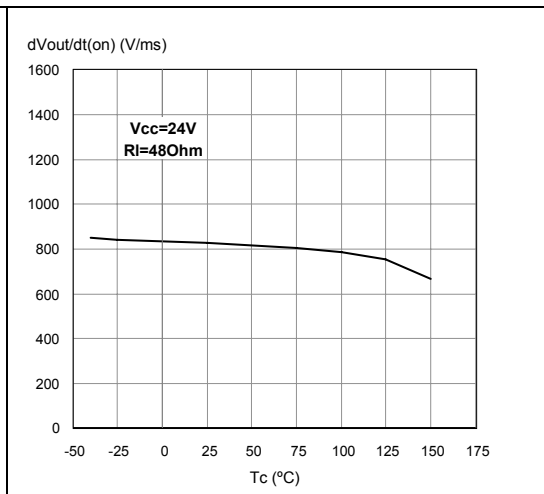

Figure 18. Overvoltage shutdown

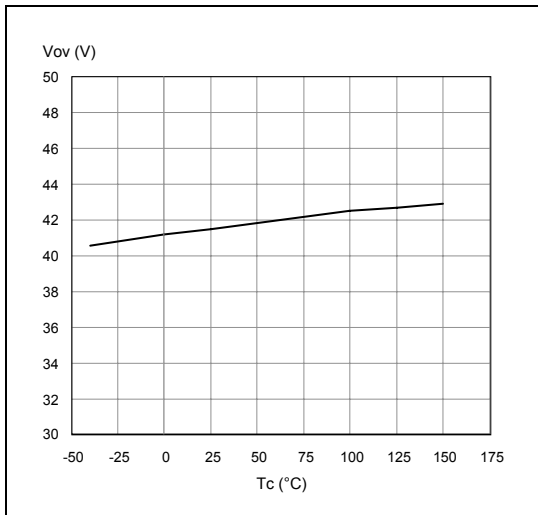

Figure 19. Input hysteresis voltage

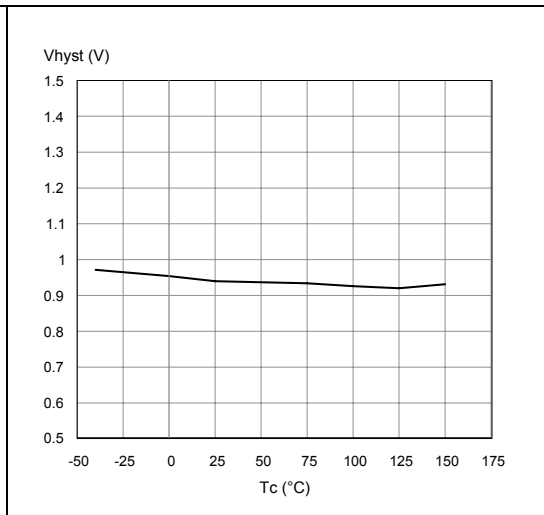

Figure 20. Turn-off voltage slope

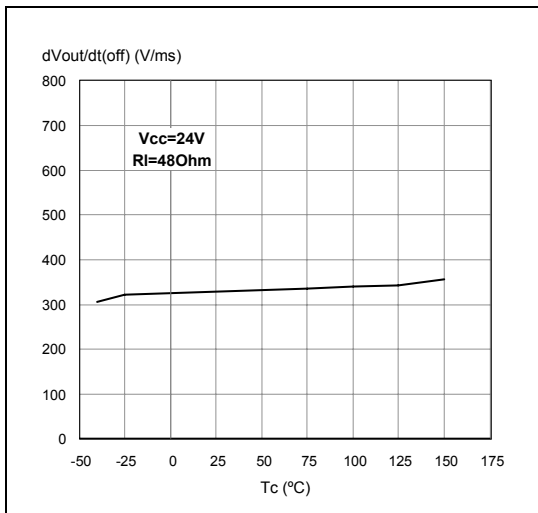
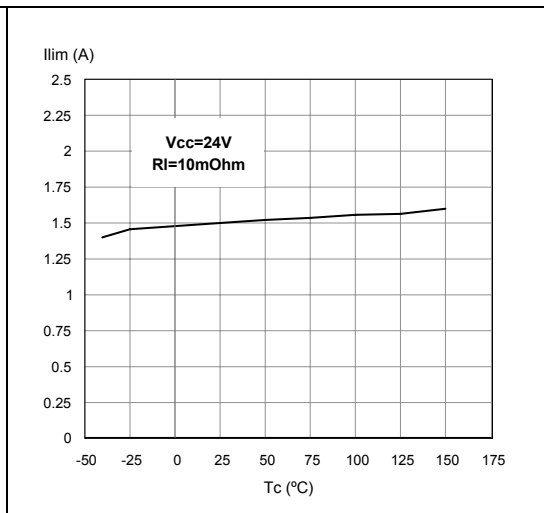
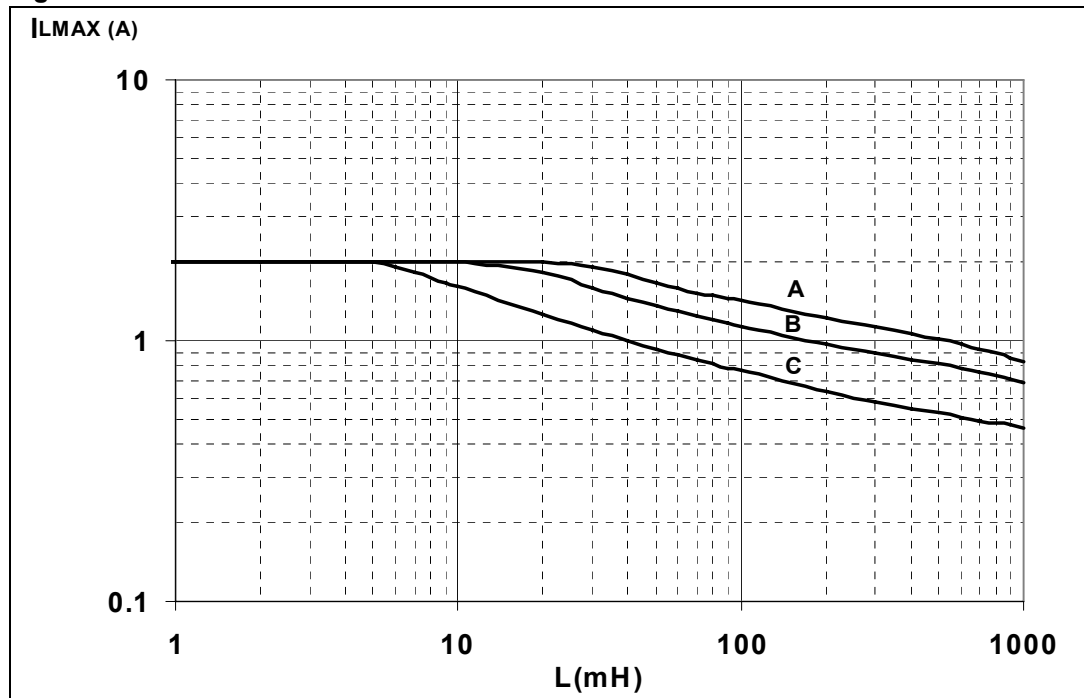

Figure 21. I_{LIM} vs T_{case}



3.4 SO-8 maximum demagnetization energy

Figure 22. SO-8 maximum turn off current versus load inductance



Note:

Legend

A = Single pulse at $T_{Jstart} = 150\text{ }^{\circ}\text{C}$

B = Repetitive pulse at $T_{Jstart} = 100\text{ }^{\circ}\text{C}$

C = Repetitive Pulse at $T_{Jstart} = 125\text{ }^{\circ}\text{C}$

Conditions:

$V_{CC} = 13.5\text{ V}$

Values are generated with $R_L = 0\text{ }\Omega$

In case of repetitive pulses, T_{Jstart} (at beginning of each demagnetization) of every pulse must not exceed the temperature specified above for curves B and C.

Figure 23. Demagnetization

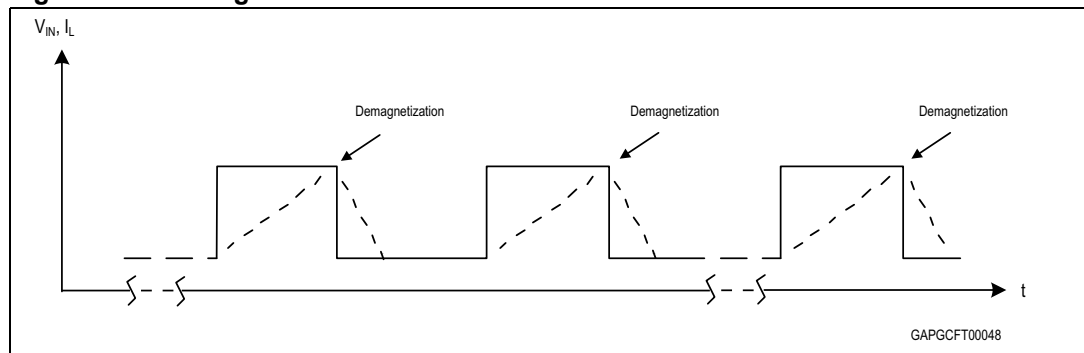

4 Package and PCB thermal data

4.1 SO-8 thermal data

Figure 24. SO-8 PC board⁽¹⁾

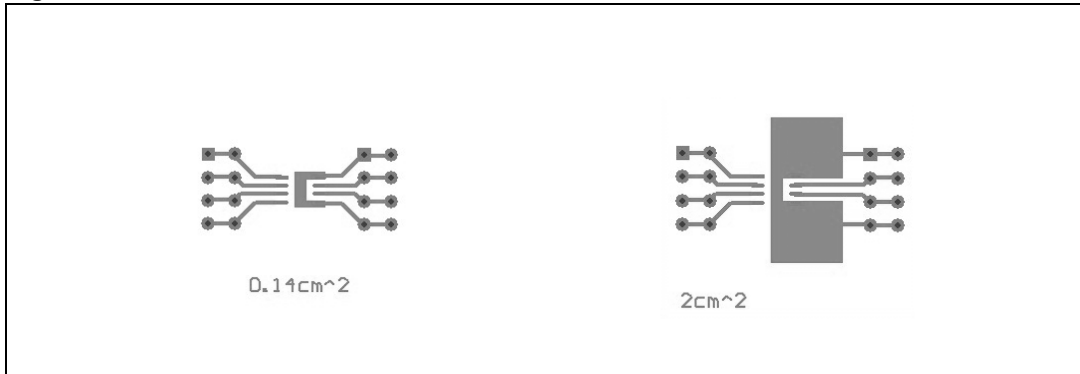

1. Layout condition of R_{th} and Z_{th} measurements (PCB FR4 area = 58 mm x 58 mm, PCB thickness = 2 mm, Cu thickness = 35 μm , Copper areas: 0.14 cm^2 , 2 cm^2).

Figure 25. SO-8 $R_{thj-amb}$ vs PCB copper area in open box free air condition

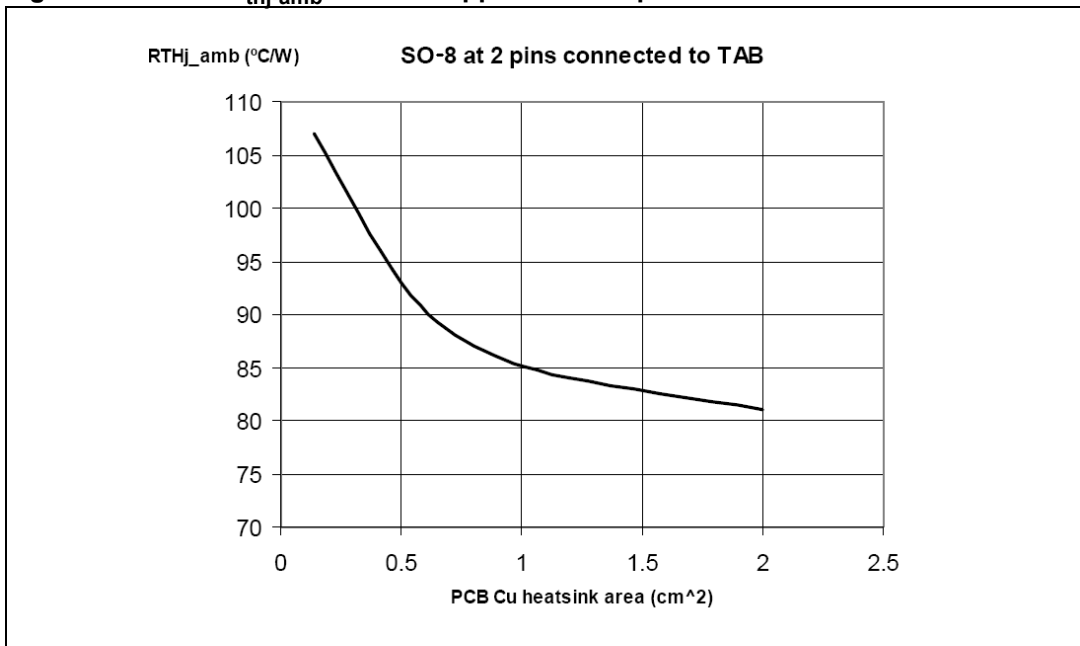

Figure 26. SO-8 thermal impedance junction ambient single pulse

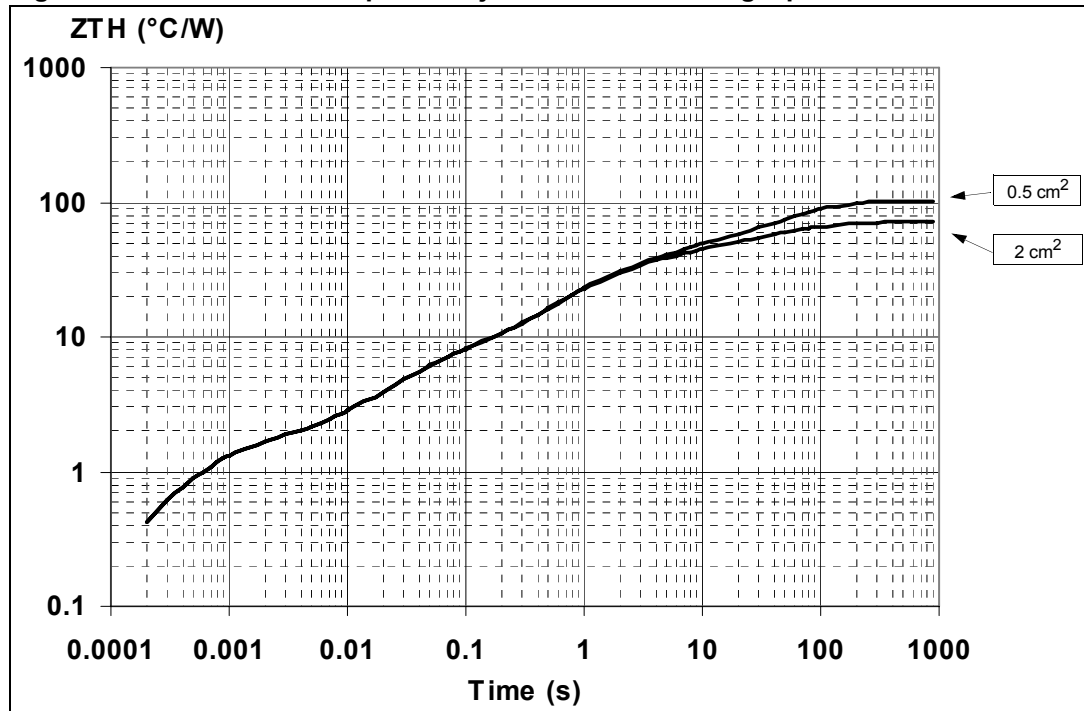
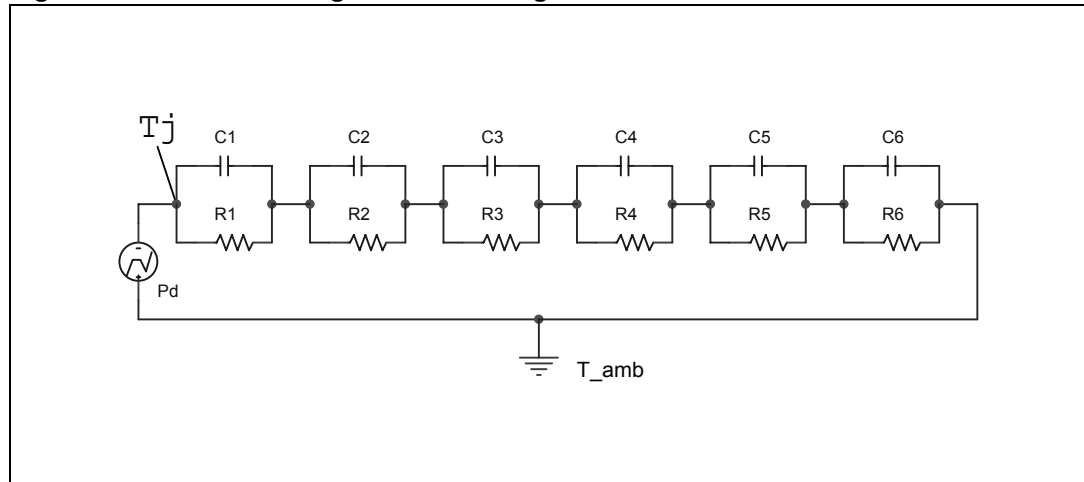

Figure 27. Thermal fitting model of a single channel HSD in SO-8



Equation 1 Pulse calculation formula

$$Z_{TH\delta} = R_{TH} \cdot \delta + Z_{THtp}(1 - \delta)$$

where

$$\delta = t_p/T$$

Table 15. Thermal parameter

Area/island (cm ²)	0.14	2
R1 (°C/W)	0.24	
R2 (°C/W)	1.2	
R3 (°C/W)	4.5	
R4 (°C/W)	21	
R5 (°C/W)	16	
R6 (°C/W)	58	28
C1 (W.s/°C)	0.00015	
C2 (W.s/°C)	0.0005	
C3 (W.s/°C)	7.50E-03	
C4 (W.s/°C)	0.045	
C5 (W.s/°C)	0.35	
C6 (W.s/°C)	1.05	2

5 Package and packing information

5.1 ECOPACK®

In order to meet environmental requirements, ST offers these devices in different grades of ECOPACK® packages, depending on their level of environmental compliance. ECOPACK® specifications, grade definitions and product status are available at: www.st.com. ECOPACK® is an ST trademark.

5.2 SO-8 package information

Table 16. SO-8 mechanical data

Dim.	mm		
	Min.	Typ.	Max.
A			1.75
a1	0.1		0.25
a2			1.65
a3	0.65		0.85
b	0.35		0.48
b1	0.19		0.25
C	0.25		0.5
c1		45	
D	4.8		5
E	5.8		6.2
e		1.27	
e3		3.81	
F	3.8		4
L	0.4		1.27
M			0.6
S			8
L1	0.8		1.2

Figure 28. SO-8 package dimensions

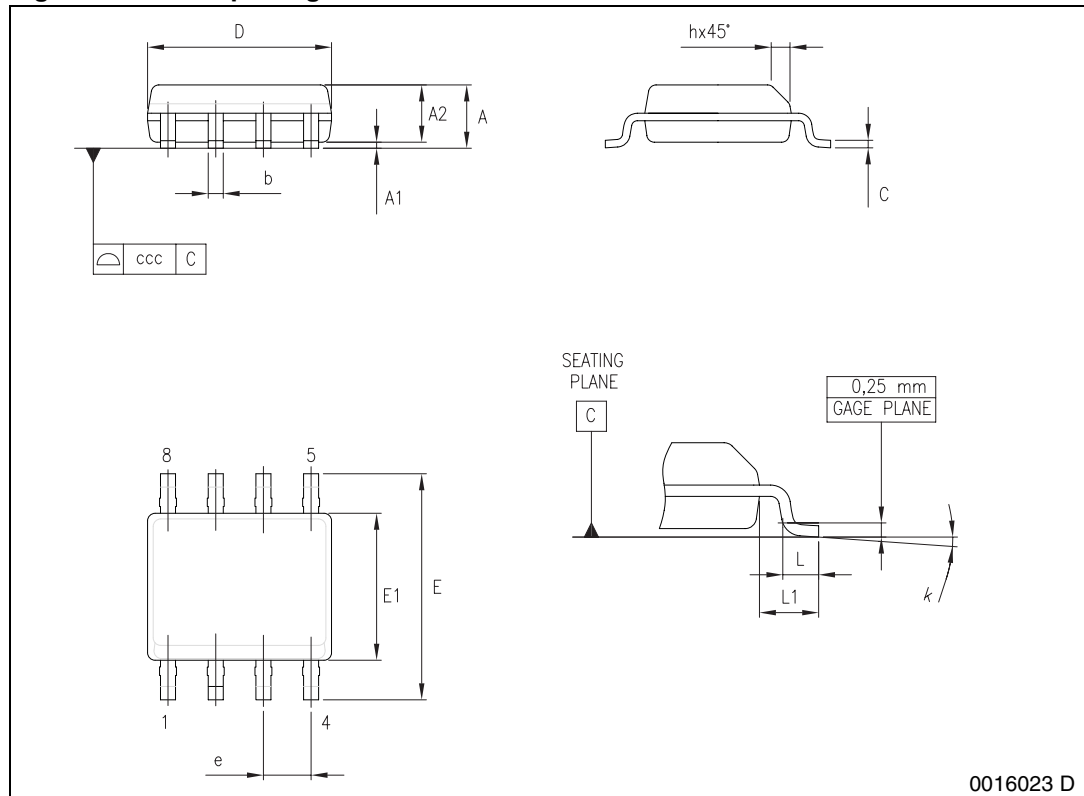

5.3 SO-8 packing information

The devices can be packed in tube or tape and reel shipments (see the [Device summary on page 1](#)).

Figure 29. SO-8 tube shipment (no suffix)

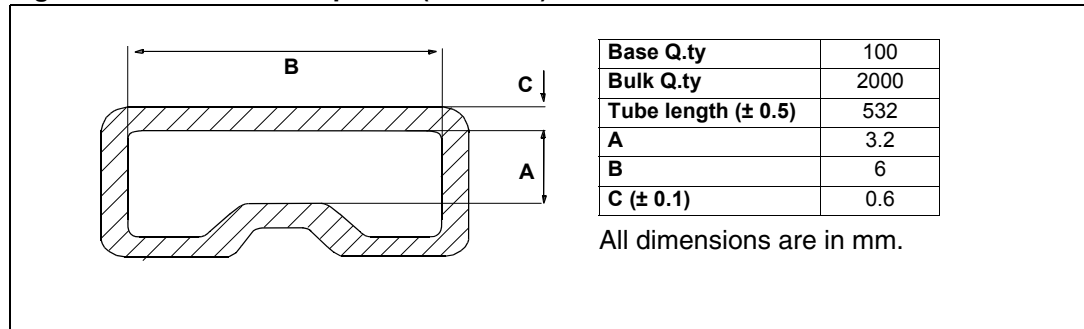
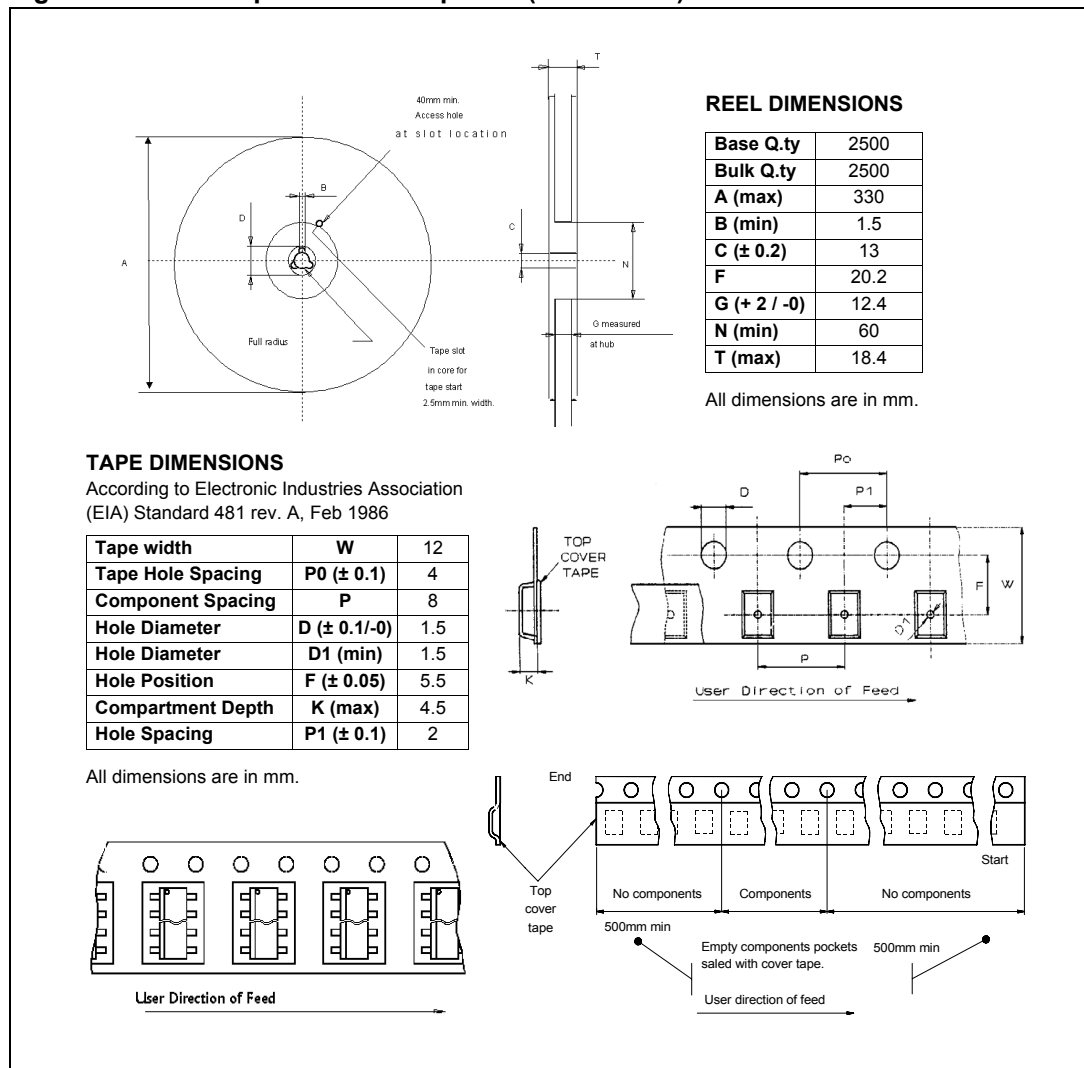

Figure 30. SO-8 tape and reel shipment (suffix “TR”)



6 Revision history

Table 17. Document revision history

Date	Revision	Changes
21-Apr-2009	1	Initial release
31-May-2010	2	Updated <i>Features</i> list. Updated <i>Table 3: Absolute maximum ratings</i> . Reformatted entire document.
07-Feb-2011	3	Updated <i>Features</i> list. Updated following tables: – <i>Table 4: Thermal data</i> – <i>Table 16: SO-8 mechanical data</i>

Please Read Carefully:

Information in this document is provided solely in connection with ST products. STMicroelectronics NV and its subsidiaries ("ST") reserve the right to make changes, corrections, modifications or improvements, to this document, and the products and services described herein at any time, without notice.

All ST products are sold pursuant to ST's terms and conditions of sale.

Purchasers are solely responsible for the choice, selection and use of the ST products and services described herein, and ST assumes no liability whatsoever relating to the choice, selection or use of the ST products and services described herein.

No license, express or implied, by estoppel or otherwise, to any intellectual property rights is granted under this document. If any part of this document refers to any third party products or services it shall not be deemed a license grant by ST for the use of such third party products or services, or any intellectual property contained therein or considered as a warranty covering the use in any manner whatsoever of such third party products or services or any intellectual property contained therein.

UNLESS OTHERWISE SET FORTH IN ST'S TERMS AND CONDITIONS OF SALE ST DISCLAIMS ANY EXPRESS OR IMPLIED WARRANTY WITH RESPECT TO THE USE AND/OR SALE OF ST PRODUCTS INCLUDING WITHOUT LIMITATION IMPLIED WARRANTIES OF MERCHANTABILITY, FITNESS FOR A PARTICULAR PURPOSE (AND THEIR EQUIVALENTS UNDER THE LAWS OF ANY JURISDICTION), OR INFRINGEMENT OF ANY PATENT, COPYRIGHT OR OTHER INTELLECTUAL PROPERTY RIGHT.

UNLESS EXPRESSLY APPROVED IN WRITING BY AN AUTHORIZED ST REPRESENTATIVE, ST PRODUCTS ARE NOT RECOMMENDED, AUTHORIZED OR WARRANTED FOR USE IN MILITARY, AIR CRAFT, SPACE, LIFE SAVING, OR LIFE SUSTAINING APPLICATIONS, NOR IN PRODUCTS OR SYSTEMS WHERE FAILURE OR MALFUNCTION MAY RESULT IN PERSONAL INJURY, DEATH, OR SEVERE PROPERTY OR ENVIRONMENTAL DAMAGE. ST PRODUCTS WHICH ARE NOT SPECIFIED AS "AUTOMOTIVE GRADE" MAY ONLY BE USED IN AUTOMOTIVE APPLICATIONS AT USER'S OWN RISK.

Resale of ST products with provisions different from the statements and/or technical features set forth in this document shall immediately void any warranty granted by ST for the ST product or service described herein and shall not create or extend in any manner whatsoever, any liability of ST.

ST and the ST logo are trademarks or registered trademarks of ST in various countries.

Information in this document supersedes and replaces all information previously supplied.

The ST logo is a registered trademark of STMicroelectronics. All other names are the property of their respective owners.

© 2011 STMicroelectronics - All rights reserved

STMicroelectronics group of companies

Australia - Belgium - Brazil - Canada - China - Czech Republic - Finland - France - Germany - Hong Kong - India - Israel - Italy - Japan - Malaysia - Malta - Morocco - Philippines - Singapore - Spain - Sweden - Switzerland - United Kingdom - United States of America

www.st.com