



UV48 MICROVERTER[®] SERIES

126-252 WATTS 48VDC INPUT 3/4 BRICK SINGLES FULL BRICK TRIPLES

DESCRIPTION

The μ V48 Series are high density DC-DC converters designed for use in telecom and other centralized modular and distributed power applications. The μ V48 Series use metal PC boards, planar transformers, and surface mount construction to produce up to 252 watts in a tiny package.

FEATURES

- Miniature Size
- High Density – Up to 58 W/in.3
- Constant Frequency – 370KHZ
- Parallelable with Current Sharing
- Fault Tolerant – n+m Redundancy
- Extremely Low Thermal Resistance
- Output Good Signal
- Optional Sync Pin
- UL/CSA/TUV APPROVALS
- Non-Shutdown OVP
- Logic On-Off
- Thermal Protection
- Current Limit/Short Circuit Protection

MODEL SELECTION

Model	Output Voltage	Output Current
μ V48-2	2.1V	60A
μ V48-3	3.3V	50A
μ V48-5	5V	40A
μ V48-8	8V	30A
μ V48-12	12V	20A
μ V48-15	15V	16A
μ V48-24	24V	10A
μ V48-28	28V	9A
μ V48-T512	5V	35A*
	12V	3A*
	-12V	3A*
μ V48-T515	5V	35A*
	15V	3A*
	-15V	3A*

*Maximum Total Output Power 185 W.
 Option: – A Output Good Deleted
 – S Sync. Pin Option



SINGLE OUTPUT

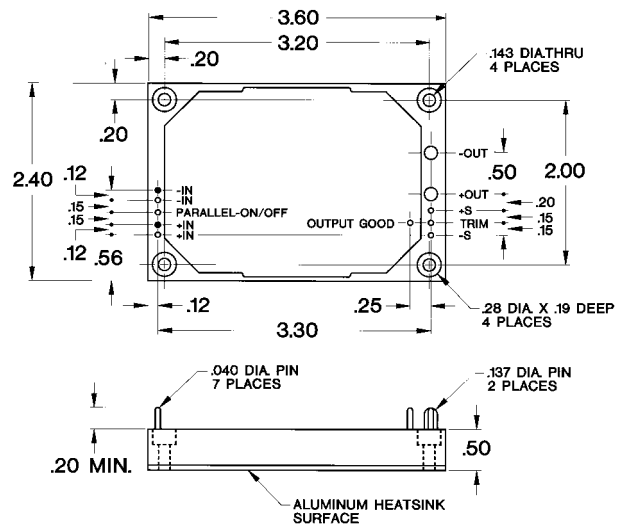

TRIPLE OUTPUT

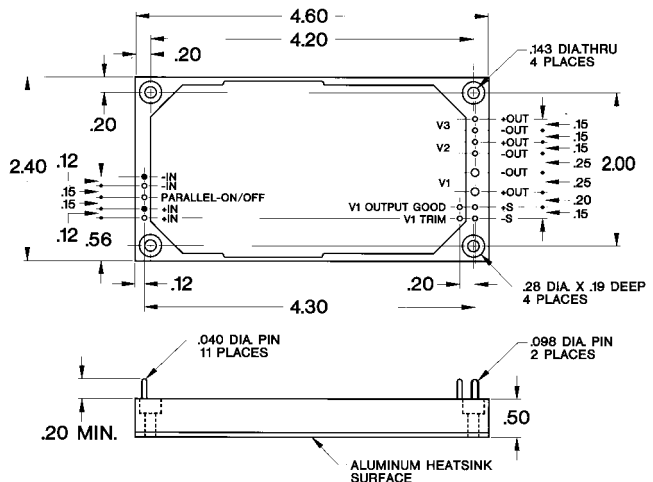



UV48 MICROVERTER SERIES SPECIFICATIONS

		Min	Typical	Max	Units	Conditions
INPUT	Input voltage	36	48	72	VDC	
	Brownout	32			VDC	75% full output
	In rush charge		2.6x10 ⁻⁴		Coulombs	
	Input re flected ripple		20		%	full load, nominal line
	No load power dissipation		2.5		watts	singles
			7.5		watts	triples
	Logic disabled power in		1		watts	
	Input ripple rejection		60		dB	@ 120 Hz
	Input overvoltage	72		100	VDC	no damage to units
OUTPUT	(Singles and Main Output of Triple)					
	Set point accuracy			± 1	%	no load
	Load regulation		.02	.2	%	0 to full load
	Line regulation		.02	.2	%	over range
	Ripple		1	3	% p-p	0 to 20MHz
	Trim range	± 10			%	consult factory for extended range
	Remote sense compensation			0.5	V total	
	OVP (non shutdown auto. recovery)		120*		%	* or Vout +.5V whichever is greater
	Current Limit (auto.recovery)		110-120		%	full load
	Current sharing (automatic)		± 5		%	full load
	Transient response singles		50		µs	20-80% load, .5A/µs, Vout 1%
	Transient response main output triples	200			µs	10-20A, aux. loads 2.5A, .25A/µs, Vout 1%
	Transient response waveforms	See web site: www.roassoc.com				
	Temp drift			.02	% /°C	
Efficiency	See Curves on Page 80					
OUTPUT	(Auxiliary Outputs of Triples)					
	Set point accuracy		± 0.5	± 1	%	10A on main, no load auxiliaries
	Load regulation		.2	.5	%	0 to full load
	Line regulation		.01	.1	%	over range
	Ripple		.25	.5	% p-p	0 to 20 mHz
	Current Limit (auto.recovery)		110-120		%	full load
	Transient response		200		µs	20-80% load, Vout within 1%
	Transient response		200		µs	low line to high line, Vout 1%
	Transient response		200		µs	50-100% load, Vout 1%
Temp drift		.06		% /°C		
CONTROL	Turn-on time		2.5		ms	input power applied, Vout 1%
	Logic turn on time		1		ms	Vout within 1%
	Logic disabled current		1		mA	sink
ISOLATION	Input to output	3000			VDC	consult factory for procedure
	Input to case	1500			VDC	
	Output to case	500			VDC	
	Input to output capacity		2200		pF	
THERMAL	Operating temperature	-40		+100	°C case	
	Automatic shut-down temperature	+100	+105	+110	°C case	
	Thermal resistance case to ambient		4.2		°C/w	single @ Tc=100 °C
			3.3		°C/w	triple @ Tc=100 °C
WEIGHT	Singles		7		oz.	
	Triples		9		oz.	
SIZE	Singles		0.5x2.4x3.6		inches	
	Triples		0.5x2.4x4.6		inches	



EFFICIENCY CURVES

CONTINUED

MICROVERTER SERIES
 2, 3 and 5V Output Models

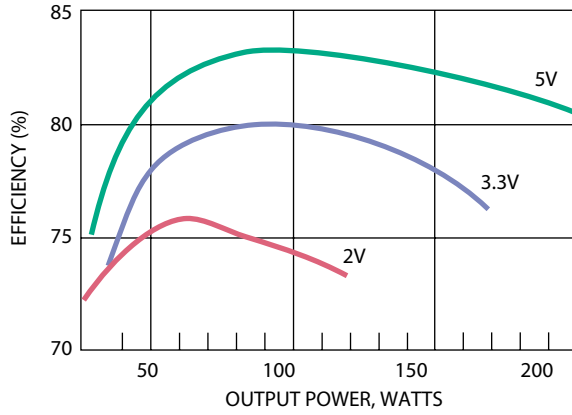

12 and 24V Output Models

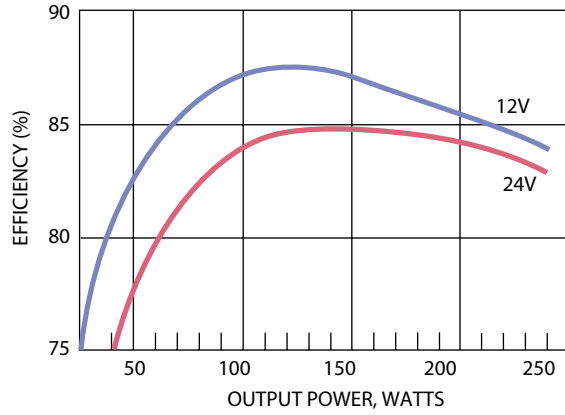

Triple Output Models

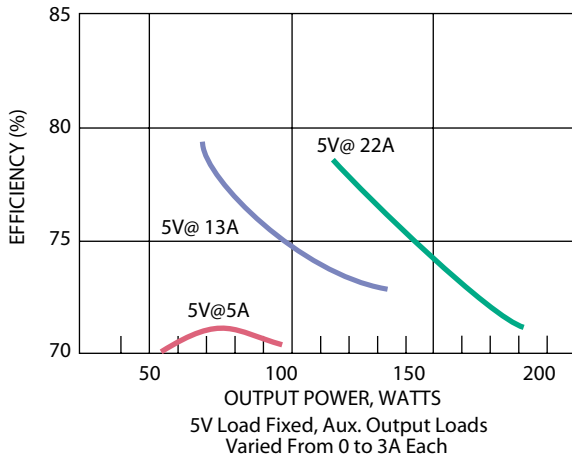

Triple Output Models

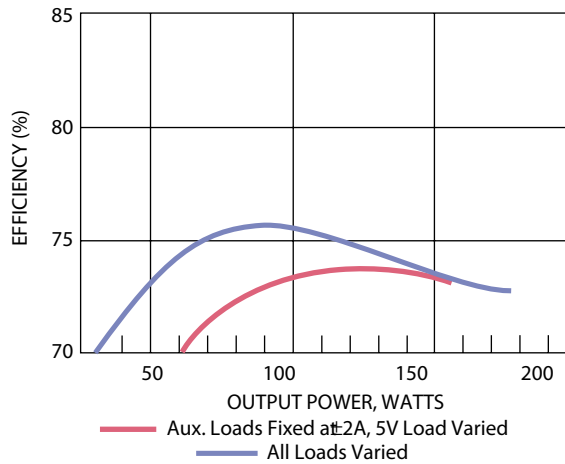

MINIMUM LOAD - TRIPLES

Minimum 5V Load vs. Auxiliary Output Power
 μ V28 and μ V48-Triple Output Models

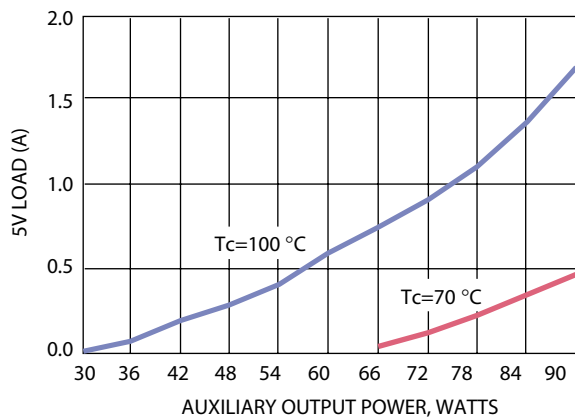

Minimum 5V Load vs. Auxiliary Output Power
 μ V300 Triple Output Models

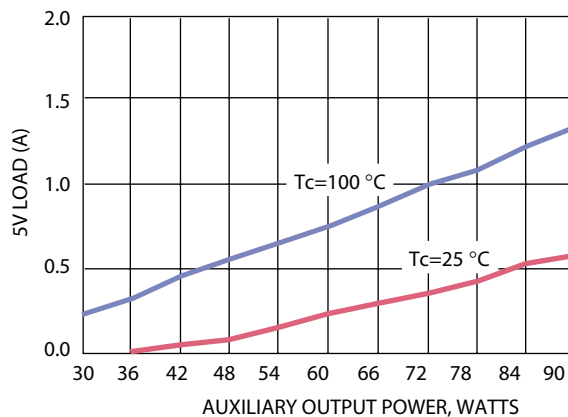

Note: Efficiencies are typical for $T_c=25^\circ\text{C}$ and Nominal Input. Input and Output Voltages are measured at the Pins.