

DESCRIPTION

The MP8001 is an IEEE 802.3 af POE compliant Powered Device (PD) controller. It includes detection and classification modes as well as a 100V output pass device having a temperature compensated current limit over the specified temperature range. Thermal protection is built in to accommodate both transient and/or overload conditions, shutting the part down and protecting the input source as well as the output load depending on the particular fault conditions. Inrush current limiting is included to slowly charge the input capacitor without interruption due to die heating, a problem encountered without the current limit foldback feature.

EVALUATION BOARD REFERENCE

Board Number	Dimensions
EV8001DS-00A	2.8"x1.7"x0.8" (LxWxH)

FEATURES

- Meets IEEE 802.3 af Specifications
- 100V, 1Ω Integrate DMOS Device
- 460mA max, Current Limit
- Open Drain Power Good Output
- 8 pin SOIC and TSSOP Packages

APPLICATIONS

- VoIP Telephones
- Network Cards
- Security Camera Systems
- Safety Backup Power
- Remote Internet Power

All MPS parts are lead-free and adhere to the RoHS directive. For MPS green status, please visit MPS website under Products, Quality Assurance page.

"MPS" and "The Future of Analog IC Technology" are registered trademarks of Monolithic Power Systems, Inc.

ADAM (Analog Digital Adaptive Modulation) and AAM (Advanced Asynchronous Mode) are trademarks of Monolithic Power Systems, Inc.

TYPICAL APPLICATION

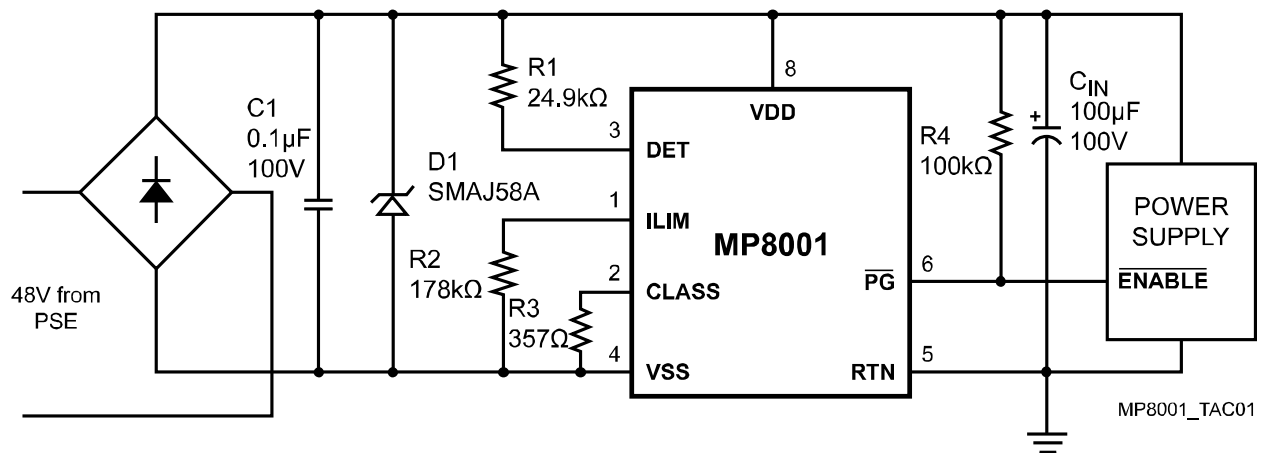

ORDERING INFORMATION

Part Number*	Package	Top Marking	Free Air Temperature (T _A)
MP8001DS	SOIC8		-40°C to +85°C

* For Tape & Reel, add suffix -Z (e.g. MP8001DS-Z).
 For RoHS compliant packaging, add suffix -LF (e.g. MP8001DS-LF-Z)

PACKAGE REFERENCE

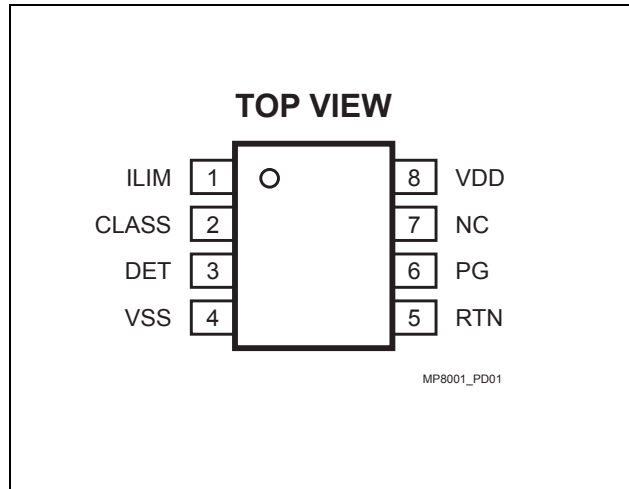

ABSOLUTE MAXIMUM RATINGS ⁽¹⁾

V _{DD} , RTN	-0.3V to +100V
PG, DET	-0.3V to +57V
I _{LIM}	-0.3V to +7V
CLASS	-0.3V to +12V
Continuous Power Dissipation(T _A = +25°C) ⁽²⁾	1.19W
Junction Temperature	150°C
Lead Temperature	260°C
Storage Temperature.....	-65°C to +150°C

Recommended Operating Conditions ⁽³⁾

Supply Voltage V _{IN}	0V to 57V
Output Current I _{OUT}	0 to 0.4A
Operating Temperature.....	-40°C to +85°C
Junction Temperature.....	-40°C to +125°C

Thermal Resistance ⁽⁴⁾	θ_{JA}	θ_{JC}
SOIC8	105	50 ... °C/W

Notes:

- 1) Exceeding these ratings may damage the device.
- 2) The maximum allowable power dissipation is a function of the maximum junction temperature T_J (MAX), the junction-to-ambient thermal resistance θ_{JA} , and the ambient temperature T_A. The maximum allowable continuous power dissipation at any ambient temperature is calculated by P_D (MAX) = (T_J (MAX)-T_A)/ θ_{JA} . Exceeding the maximum allowable power dissipation will cause excessive die temperature, and the regulator will go into thermal shutdown. Internal thermal shutdown circuitry protects the device from permanent damage.
- 3) The device is not guaranteed to function outside of its operating conditions.
- 4) Measured on JESD51-7, 4-layer PCB.

ELECTRICAL CHARACTERISTICS

$V_{DD} = 48V$, all voltages with respect to V_{SS} , $V_{SS} = 0V$; $R_{DET} = 26.1k\Omega$, $R_{CLASS} = 4.42k\Omega$, $R_{ILIM} = 178k\Omega$, $T_A = 25^\circ C$, unless otherwise noted.

Parameter	Symbol	Condition	Min	Typ	Max	Units	
Detection							
Detection on	V_{DET_ON}	$V_{DD}=V_{RTN}=V_{PG}=1.9V$		1.9		V	
Detection off	V_{DET_OFF}	$V_{DD}=V_{RTN}=V_{PG}=11V$		11		V	
Detection on/off Hysteresis	V_{DET_H}	Falling below 11V on Threshold		0.2		V	
DET Leakage Current	V_{DET_LK}	$V_{DET}=V_{VDD}=57V$, Measure I_{DET}		0.1	5	μA	
Detection Current	I_{DET}	$V_{VDD}=V_{RTN}$ $R_{DET}=26.1k\Omega$, Measure $I_{VDD}+I_{RTN}+I_{DET}$	$V_{DD} = 3V$	135	140	145	μA
			$V_{DD} = 10.1V$	405	420	435	μA
Classification							
V_{CLASS} Output Voltage	V_{CL}	Over a Load Range of 1mA to 41.2 mA	9.6	10	10.3	V	
Classification Current	I_{CLASS}	$R_{CLASS}=4420\Omega$, $13\leq V_{VDD}\leq 21V$ (guar by V_{CL})	2.2	2.4	2.8	mA	
		$R_{CLASS}=953\Omega$, $13\leq V_{VDD}\leq 21V$ (guar by V_{CL})	10.3	10.6	11.3		
		$R_{CLASS}=549\Omega$, $13\leq V_{VDD}\leq 21V$ (guar by V_{CL})	17.7	18.3	19.5		
		$R_{CLASS}=357\Omega$, $13\leq V_{VDD}\leq 21V$ (guar by V_{CL})	27.1	28	29.5		
		$R_{CLASS}=255\Omega$, $13\leq V_{VDD}\leq 21V$ (guar by V_{CL})	38	39.4	41.2		
Classification Lower Threshold	V_{CL_ON}	Regulator Turns on, V_{VDD} Rising	10.2	11.3	13	V	
Classification Upper Threshold	V_{CU_OFF}	Regulator Turns off, V_{VDD} Rising	21	21.9	23	V	
	V_{CU_H}	Hysteresis		0.4		V	
IC Supply Current during Classification	I_{IN_CLASS}	$V_{DD} = 17.5V$, CLASS Floating, RTN Tied to VSS		300	500	μA	
Leakage Current	$I_{LEAKAGE}$	$V_{CLASS} = 0V$, $V_{VDD} = 57V$			1	μA	
Pass Device							
On Resistance	$R_{DS(ON)}$	$I_{RTN}=300mA$		1.0	1.2	Ω	
Leakage Current	I_{SW_LK}	$V_{VDD}=V_{RTN}=57V$		1	15	μA	
Current Limit	I_{LIMIT}	$V_{RTN}=1V$	380	420	460	mA	
Inrush Limit	I_{INRUSH}	$V_{RTN}=2V$, $R_{ILM}=178k\Omega$	120	150	180	mA	
PG							
Latchoff Voltage Threshold Rising		V_{RTN} Rising ⁽⁵⁾	9.5	10	10.5	V	
Latchoff Voltage Threshold Falling		V_{RTN} Falling ⁽⁵⁾		1.2		V	
PG Deglitch		Delay Rising and Falling PDG ⁽⁵⁾	75	150	225	μs	
Output Low Voltage		$I_{PG} = 400 \mu A$		0.12	0.4	V	

ELECTRICAL CHARACTERISTICS*(continued)*

$V_{DD} = 48V$, all voltages with respect to V_{SS} , $V_{SS} = 0V$; $R_{DET} = 26.1k\Omega$, $R_{CLASS} = 4.42K\Omega$,
 $R_{ILIM} = 178k\Omega$, $T_A = 25^\circ C$, unless otherwise noted.

Parameter	Symbol	Condition	Min	Typ	Max	Units
Leakage Current		$V_{PG} = 57 V$, $V_{RTN} = 0 V$		0.1	1	μA
UVLO						
Voltage at V_{VDD}		V_{VDD} Rising (including 1.4V Diode drop)	38	40	42	V
		V_{VDD} Falling (including 1.4V Diode drop)	30.2	31.5	32.8	
Thermal Shutdown						
Thermal Shut down Temperature	T_{RISE}	Temperature Rising	135			$^\circ C$
Hysteresis	T_{HYS}			40		$^\circ C$
Thermal Shut down Counter	T_{COUNT}	Events Prior to Latch off ⁽⁵⁾		8		counts
Thermal Counter Reset Voltage	V_{CRST}	Must Drop below Classification Range ⁽⁵⁾		10.8		V
Bias Current						
Operating Current	$I_{Q(VDD)}$	$V_{DD} = 48V$, Pins 5, 6 Floating Measure I_{VDD}		240	450	μA

Notes:

5) Guaranteed by Design.

PIN FUNCTIONS

Pin #	Name	Description
1	ILIM	Startup I_{LIM} Value Set (optional at this point).
2	CLASS	Classification Resistor.
3	DET	26.1k Ω Detection Resistor.
4	VSS	Negative Power Supply Terminal.
5	RTN	Powered Device Negative Power Terminal.
6	PG	Power Good Indicator.
7	NC	No Connect. Possible post-package trim input.
8	VDD	Positive Power Supply Terminal.

OPERATION

The MP8001 operates in the manner described here and in the IEEE 802.3af Powered Device (PD) Specifications. This device (along with the power sourcing element (PSE)) operates as a safety device to supply potentially lethal voltages only when the power sourcing element recognizes a unique, tightly specified resistance at the end of an unknown length of Ethernet cable.

A 25k Ω resistance is presented as a load to the PSE in Detection Mode, when the PSE applies two “safe” voltages of less than 10.1V each while measuring the change in current drawn in order to determine the load resistance. If the PSE “sees” the correct load, then it may either further increase the applied voltage to enter the “classification” range of operation or switch on the nominal 48V power to the load.

The classification mode can further specify to the PSE the expected load range of the device under power so that the PSE can intelligently distribute power to as many loads as possible (within its maximum current capabilities). If a classification resistance is not present, the PD load is assumed to be the maximum of approximately 13 Watts. The classification mode is active between 14.5V and 20.5V.

The main power switch will pass a limited current above 31V, charging the external DC-to-DC converter’s input capacitor in a controlled manner. The charging will continue until the controlled current drops below the either an externally programmed limiting level or 450mA, depending upon the R_{lim} current setting resistor. The main power switch is internally thermally protected to 100V by reducing the output current using a foldback technique. The required power dissipation of the IC drops from the allowed peak value of 26W (450mA x 57V) to 0.16W $((450mA)^2 \times R_{ON})$ during the normal operation at turn-on. The minimum allowed capacitance of 5 μ F will charge in 500 μ s. A larger capacitor will take a proportionally longer time to charge due to the constant current charging method. If a capacitor that is too large will overheat the part and force it into thermal shutdown. The IC will reattempt charging for a number of cycles but ultimately will be shut down until the input voltage from the PSE is recycled. This is the way the IC protects itself under overload and/or shorted conditions.

BLOCK DIAGRAM

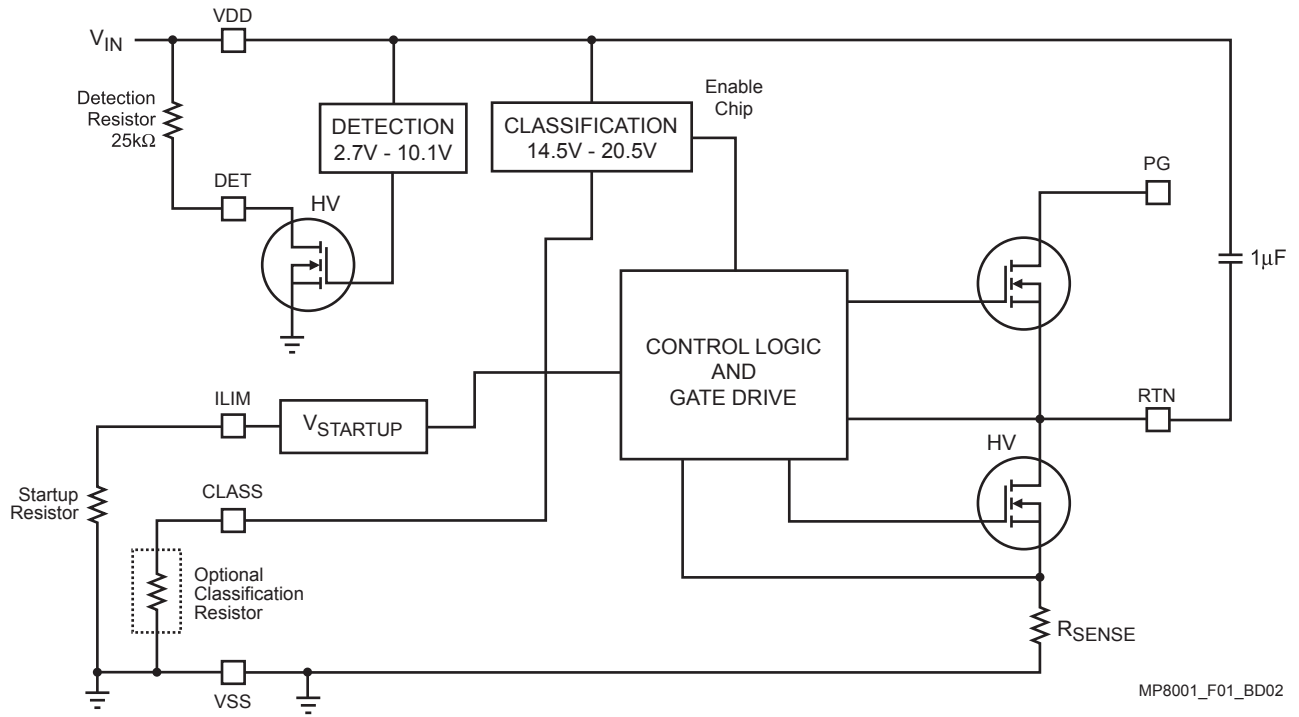
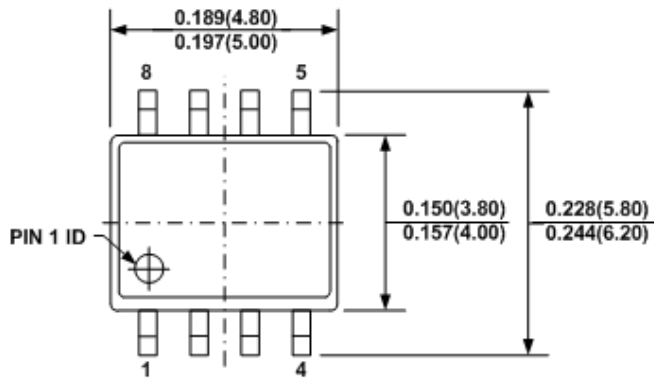

Figure 1—PD Block Diagram

MP8001_F01_BD02

PACKAGE INFORMATION

SOIC8



TOP VIEW

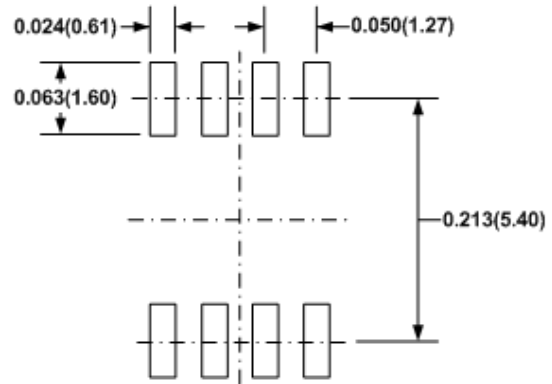

RECOMMENDED LAND PATTERN

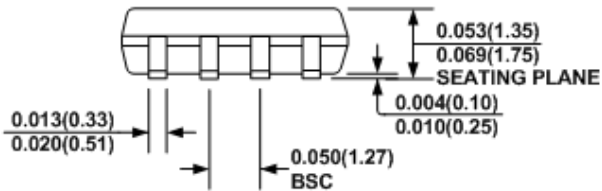

FRONT VIEW

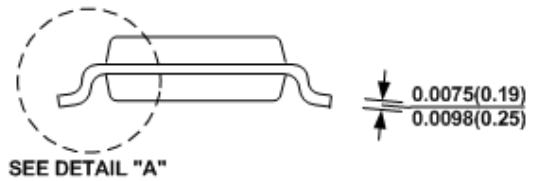

SIDE VIEW

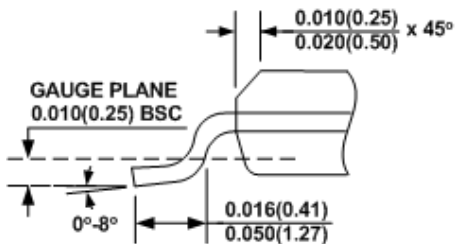

DETAIL "A"

NOTE:

- 1) CONTROL DIMENSION IS IN INCHES. DIMENSION IN BRACKET IS IN MILLIMETERS.
- 2) PACKAGE LENGTH DOES NOT INCLUDE MOLD FLASH, PROTRUSIONS OR GATE BURRS.
- 3) PACKAGE WIDTH DOES NOT INCLUDE INTERLEAD FLASH OR PROTRUSIONS.
- 4) LEAD COPLANARITY (BOTTOM OF LEADS AFTER FORMING) SHALL BE 0.004" INCHES MAX.
- 5) DRAWING CONFORMS TO JEDEC MS-012, VARIATION AA.
- 6) DRAWING IS NOT TO SCALE.

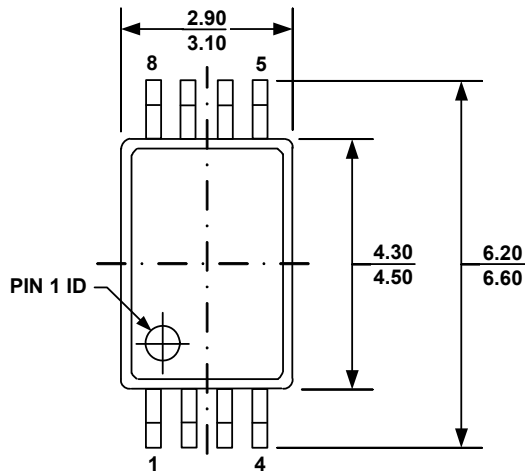
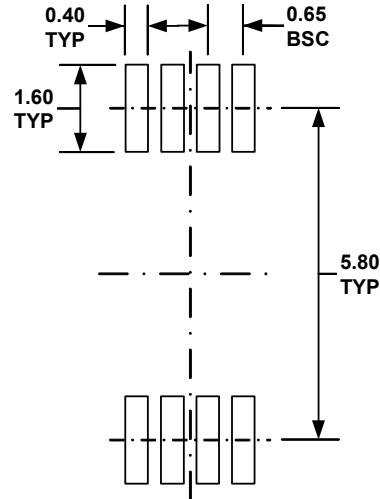
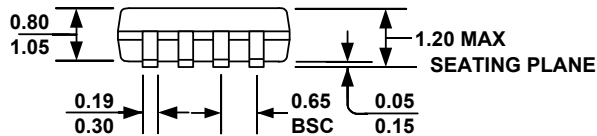
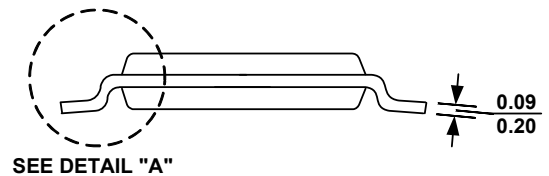
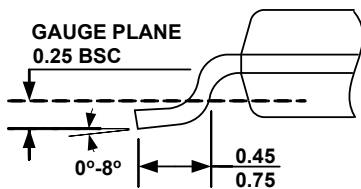
TSSOP8
**PACKAGE OUTLINE DRAWING FOR 8-TSSOP
MF-PO-D-0038 revision 0.0**

TOP VIEW

RECOMMENDED LAND PATTERN

FRONT VIEW

SIDE VIEW

DETAIL 摺
NOTE:

- 1) ALL DIMENSIONS ARE IN MILLIMETERS.
- 2) PACKAGE LENGTH DOES NOT INCLUDE MOLD FLASH, PROTRUSION OR GATE BURR.
- 3) PACKAGE WIDTH DOES NOT INCLUDE INTERLEAD FLASH OR PROTRUSION.
- 4) LEAD COPLANARITY (BOTTOM OF LEADS AFTER FORMING) SHALL BE 0.10 MILLIMETERS MAX.
- 5) DRAWING CONFORMS TO JEDEC MO-153, VARIATION AA.
- 6) DRAWING IS NOT TO SCALE.

NOTICE: The information in this document is subject to change without notice. Please contact MPS for current specifications. Users should warrant and guarantee that third party Intellectual Property rights are not infringed upon when integrating MPS products into any application. MPS will not assume any legal responsibility for any said applications.