

7132

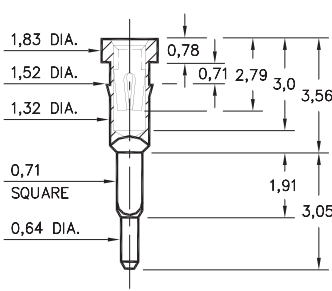

7132-0-15-XX-30-XX-04-0
Square press-fit for 0,81 ±0,05 plated thru hole

8445

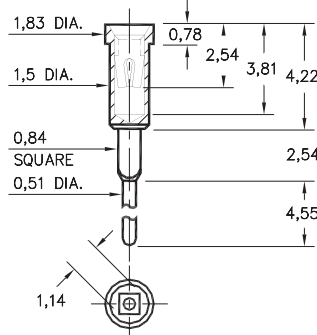

8445-0-15-XX-30-XX-04-0
Square press-fit for 0,99 ±0,05 plated thru hole

1038

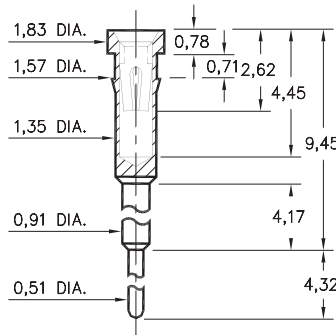

1038-0-15-XX-30-XX-04-0
Press-fit in 1,5 mounting hole

1261

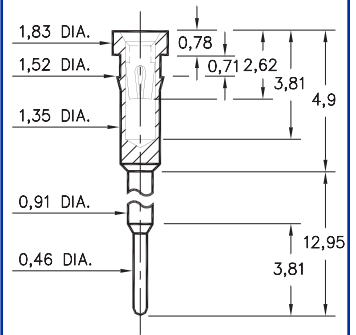

1261-0-15-XX-30-XX-04-0
Press-fit in 1,45 mounting hole

0153

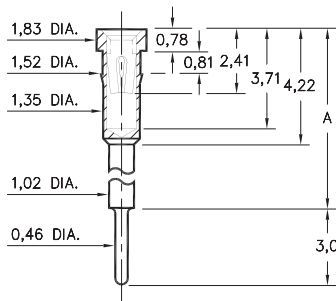

0153-X-15-XX-30-XX-04-0
Press-fit in 1,45 mounting hole

Basic Part Number	Height A
0153-1	5,99
0153-2	8,0
0153-3	10,21
0153-4	11,99
0153-5	15,09
0153-6	17,75

1602/1610

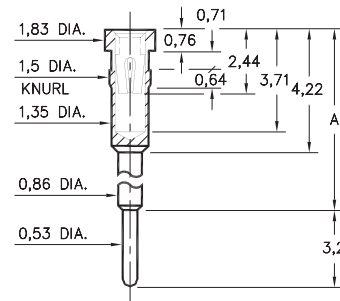

16XX-0-15-XX-30-XX-04-0
Press-fit in 1,45 mounting hole

Basic Part Number	Height A
1602-0	11,2
1610-0	16,31

0903/0904

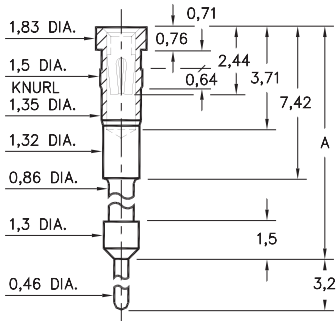

090X-0-15-XX-30-XX-04-0
Press-fit in 1,45 mounting hole

Basic Part Number	Height A
0903-0	21,36
0904-0	28,98

8252

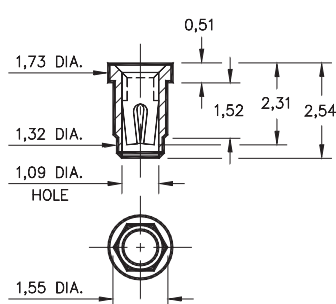

8252-0-15-XX-30-XX-10-0
Press-fit in 1,45 plated thru hole

4078

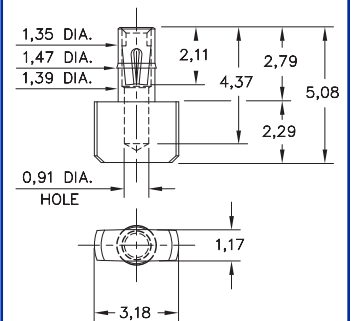

4078-0-15-XX-30-XX-40-0
Press-fit in 1,45 mounting hole

SPECIFICATIONS

SHELL MATERIAL:
Brass Alloy 360, 1/2 Hard

CONTACT MATERIAL:
Beryllium Copper Alloy 172, HT

DIMENSION IN INCHES
TOLERANCES ON:
LENGTHS: ±0,13
DIAMETERS: ±0,05
ANGLES: ± 2°

ORDER CODE: XXXX - X - 15 - XX - 30 - XX - XX - 0

BASIC PART #

SPECIFY SHELL FINISH:
01 5,08µm TIN/LEAD OVER NICKEL
◇ 80 5,08µm TIN OVER NICKEL (RoHS)
◇ 15 0,25µm GOLD OVER NICKEL (RoHS)

SPECIFY CONTACT FINISH:
02 2,54µm TIN/LEAD OVER NICKEL
◇ 84 2,54µm TIN OVER NICKEL (RoHS)
◇ 27 0,76µm GOLD OVER NICKEL (RoHS)



CONTACT

#30 CONTACT (DATA ON PAGES 218)