

■ Features

- Large current capacity ( $I_C=1A$ )
- High blocking voltage ( $V_{CE0} \geq 400V$ )

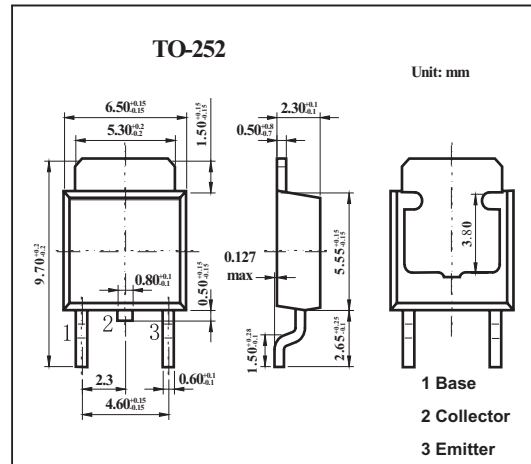

■ Absolute Maximum Ratings  $T_a = 25^\circ C$

Parameter	Symbol	Rating	Unit
Collector to base voltage	$V_{CBO}$	400	V
Collector to emitter voltage	$V_{CEO}$	400	V
Emitter to base voltage	$V_{EBO}$	5	V
Peak collector current	$I_{CP}$	2	A
Collector current	$I_C$	1	A
Collector power dissipation $T_C=25^\circ C$	$P_C$	1	W
		15	W
Junction temperature	$T_j$	150	$^\circ C$
Storage temperature	$T_{stg}$	-55 to +150	$^\circ C$

■ Electrical Characteristics Ta = 25°C

Parameter	Symbol	Testconditions	Min	Typ	Max	Unit
Collector cut-off Current	IcBO	Vcb=300V, Ie=0			1	μA
Emitter Cut-off Current	IeBO	Veb=4V, Ic=0			1	μA
DC Current Gain	hFE	Vce=10V, Ic=100mA	40		200	
Gain-Bandwidth product	fT	Vce=10V, Ic=50mA		70		MHz
C-E Saturation Voltage	VCE(sat)	Ic=200mA, Ib=20mA			1	V
B-E Saturation Voltage	VBE(sat)	Ic=200mA, Ib=20mA			1	V
C-B Breakdown Voltage	V(BR)CBO	Ic=10μA, Ie=0	400			V
C-E Breakdown Voltage	V(BR)CEO	Ic=1mA, RBE=∞	400			V
E-B Breakdown Voltage	V(BR)EBO	Ie=10μA, Ic=0	5			V
Output capacitance	Cob	Vcb=30V, f=1MHz		8		pF
Turn-ON Time	ton	<p>Unit (Resistance:Ω , Capacitance:F)</p>		11		μs
Storage Time	tstg			4		
Fall Time	tr			0.65		

■ hFE Classification

TYPE	C	D	E
hFE	40 to 80	60 to 120	100 to 200