

KMB12F thru KMB110F

Reverse Voltage 20 to 100 V

Forward Current 1.0 A

Features

- 大电流承受能力。High Current Capability
- 正向压降低。Low Forward Voltage Drop
- 高温焊接保证 High temperature soldering guaranteed:
260°C/10 秒 seconds at terminals

Mechanical Data

- 封装: 塑料封装 Case: Molded plastic body
- 端子: 焊料被镀 Terminals: Solder plated
- 极性: 色环端为负极 Polarity: Color band denotes cathode end
- 安装位置: 任意 Mounting Position: Any

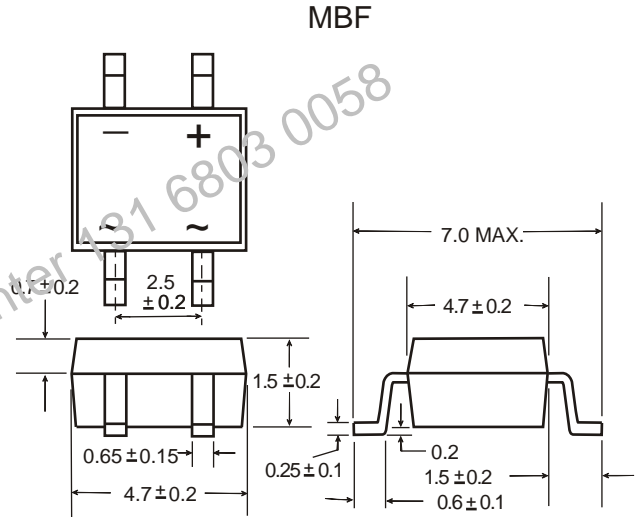

Dimensions in millimeters(1mm =0.0394")

Maximum Ratings & Thermal Characteristics Ratings at 25°C ambient temperature unless otherwise specified.

	Symbols	KMB12F	KMB14F	KMB16F	KMB18F	KMB110F	Unit
最大峰值反向电压 Maximum repetitive peak reverse voltage	V_{RRM}	20	40	60	80	100	V
最大反向有效值电压 Maximum RMS voltage	V_{RMS}	14	28	42	56	70	V
最大直流阻断电压 Maximum DC blocking voltage	V_{DC}	20	40	60	80	100	V
最大正向平均整流电流 Maximum average forward rectified current	$I_{F(AV)}$	1.0					A
正向峰值浪涌电流 8.3ms单一正弦半波 Peak forward surge current 8.3 ms single half sine-wave	I_{FSM}	30					A
典型热阻 Typical thermal resistance	$R_{\theta JA}$	75					°CW
工作结温和存储温度 Operating junction and storage temperature range	T_J, T_{STG}	-50----+150					°C

Electrical Characteristics Ratings at 25°C ambient temperature unless otherwise specified.

	Symbols	KMB12F	KMB14F	KMB16F	KMB18F	KMB110F	Unit
最大正向电压 $I_F = 1.0A$ Maximum forward voltage	V_F	0.50		0.70	0.85		V
最大反向漏电流 $T_A = 25^\circ C$ Maximum reverse current $T_A = 100^\circ C$	I_R	0.5			20		mA
典型结电容 $V_R = 4.0V, f = 1MHz$ Type junction capacitance	C_J	15					pF

Characteristic Curves

