

Thick Film Resistor/Capacitor Chip, Surface Mount

FEATURES

- Single component reduces board space and component counts
- Choice of dielectric characteristics X7R or Y5U
- Wrap around termination
- Thick film resistor/capacitor element
- Inner electrode protection
- Flow and reflow solderable
- Automatic placement capability, standard size

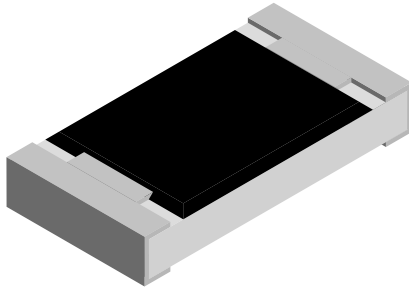

STANDARD ELECTRICAL SPECIFICATIONS											
GLOBAL MODEL	SIZE		RESISTOR CHARACTERISTICS				CAPACITOR CHARACTERISTICS				
	INCH	METRIC	POWER RATING $P_{70^{\circ}\text{C}}$ W	TEMPERATURE COEFFICIENT \pm ppm/ $^{\circ}\text{C}$	RES. TOL. \pm %	RES. RANGE Ω	DIELECTRIC	TEMPERATURE COEFFICIENT %	CAP. TOL. \pm %	CAP. VOLTAGE V_{DC}	CAP. RANGE pF
CRCC1206	1206	3216	0.125	200	5	10 to 1M	X7R	± 15	20	50	10 to 270
CRCC1206	1206	3216	0.125	200	5	10 to 1M	Y5U	+ 22, - 56	20	50	270 to 1800
RESISTOR						CAPACITOR					
<ul style="list-style-type: none"> • Operating temperature range: - 55 $^{\circ}\text{C}$ to + 125 $^{\circ}\text{C}$ • Technology: Thick film 						<ul style="list-style-type: none"> • Operating temperature range: X7R - 55 $^{\circ}\text{C}$ to + 125 $^{\circ}\text{C}$ Y5U - 30 $^{\circ}\text{C}$ to + 85 $^{\circ}\text{C}$ • Maximum dissipation factor: 2.5 % 					

Notes

- Packaging: See appropriate catalog or web page.
- Power rating depends on the maximum temperature at the solder point, the component placement density and the substrate material.

TECHNICAL SPECIFICATIONS				
PARAMETER	UNIT	RESISTOR	X7R CAPACITOR	Y5U CAPACITOR
Rated dissipation at 70 $^{\circ}\text{C}$	W	0.125	-	-
Capacitor voltage rating	V	-	50	50
Dielectric withstanding voltage (5 s, 50 mA Charge)	V_{DC}	-	125	125
Category temperature range	$^{\circ}\text{C}$	- 55/+ 125	- 55/+ 125	- 30/+ 85
Insulation resistance	Ω	$> 10^{10}$	$> 10^{10}$	$> 10^{10}$
Weight/1000 pieces	g	0.65	2	5.5

GLOBAL PART NUMBER INFORMATION																	
New Global Part Numbering: CRCC1206472J220MTF (preferred part numbering format)																	
C	R	C	C	1	2	0	6	4	7	2	J	2	2	0	M	T	F
GLOBAL MODEL CRCC1206	RESISTANCE VALUE 2 digit significant figure, followed by a multiplier 100 = 10 Ω 683 = 68 k Ω 105 = 1.0 M Ω		RES. TOLERANCE F = ± 1 % G = ± 2 % J = ± 5 %	CAPACITANCE VALUE (pF) 2 digit significant figure, followed by a multiplier 100 = 10 pF 271 = 270 pF 182 = 1800 pF		CAP. TOLERANCE K = ± 10 % M = ± 20 %	PACKAGING EA = Lead (Pb)-free, T/R (4000 pieces) TF = Tin/Lead, T/R (4000 pieces)										
Historical Part Number Example: CRCC1206472J220MR02 (will continue to be accepted)																	
CRCC1206	472	J	220	M	R02												
MODEL	RESISTANCE VALUE	RES. TOLERANCE	CAPACITANCE VALUE	CAP. TOLERANCE	PACKAGING												

DIMENSIONS

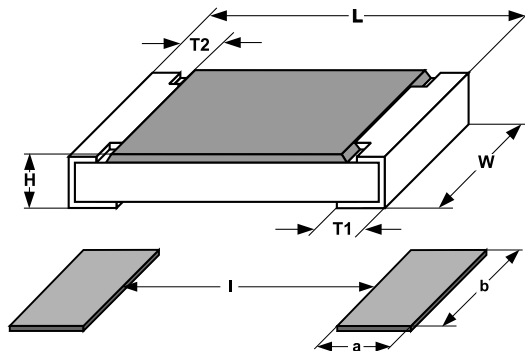

SIZE		DIMENSIONS in millimeters				
INCH	METRIC	L	W	H	T1	T2
1206	3216	3.2 ± 0.15	1.6 ± 0.15	0.55 ± 0.15	0.5 ± 0.25	0.5 ± 0.25

SIZE		SOLDER PAD DIMENSIONS in millimeters					
		REFLOW SOLDERING			WAVE SOLDERING		
INCH	METRIC	a	b	l	a	b	l
1206	3216	0.9	1.7	2.0	1.1	1.7	2.2

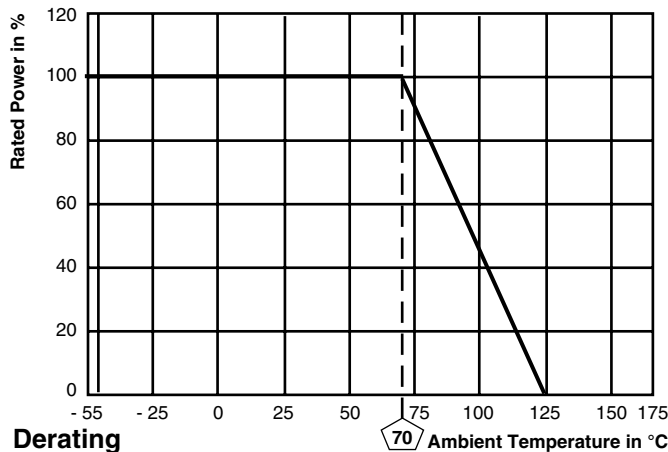

SCHEMATIC

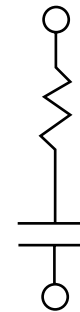

PERFORMANCE			
TEST	CONDITIONS OF TEST	TEST RESULTS (TYPICAL TEST LOTS)	
		R	C
Endurance test at 70 °C MIL-Std-202 method 108	1000 h at 70 °C, 1.5 h "ON", 0.5 h "OFF"	± (5 % + 2 Ω)	± 20 %
Dielectric withstanding voltage MIL-Std-202 method 301	125 V _{DC} , 5 s, 50 mA charge	No physical damage	
Thermal shock MIL-Std-202 method 107	100 cycles, - 55 °C to + 125 °C	± (5 % + 2 Ω)	± 20 %
Moisture MIL-Std-202 method 106	Omit steps 7A and B	± (5 % + 2 Ω)	± 20 %
Resistance to soldering heat EIA 575	10 s at 260 °C solder bath temperature	± (5 % + 2 Ω)	± 20 %
High temperature exposure EIA 575	125 °C for 100 h	± (5 % + 2 Ω)	± 20 %
Low temperature operation EIA 575	1 h at - 55 °C then 45 min at 50 V	± (5 % + 2 Ω)	± 20 %
Solderability and leaching EIA 575 3.12	Condition C	95 % coverage	

APPLICABLE SPECIFICATIONS
<ul style="list-style-type: none"> • IPC standards • EIA 575



Disclaimer

ALL PRODUCT, PRODUCT SPECIFICATIONS AND DATA ARE SUBJECT TO CHANGE WITHOUT NOTICE TO IMPROVE RELIABILITY, FUNCTION OR DESIGN OR OTHERWISE.

Vishay Intertechnology, Inc., its affiliates, agents, and employees, and all persons acting on its or their behalf (collectively, "Vishay"), disclaim any and all liability for any errors, inaccuracies or incompleteness contained in any datasheet or in any other disclosure relating to any product.

Vishay makes no warranty, representation or guarantee regarding the suitability of the products for any particular purpose or the continuing production of any product. To the maximum extent permitted by applicable law, Vishay disclaims (i) any and all liability arising out of the application or use of any product, (ii) any and all liability, including without limitation special, consequential or incidental damages, and (iii) any and all implied warranties, including warranties of fitness for particular purpose, non-infringement and merchantability.

Statements regarding the suitability of products for certain types of applications are based on Vishay's knowledge of typical requirements that are often placed on Vishay products in generic applications. Such statements are not binding statements about the suitability of products for a particular application. It is the customer's responsibility to validate that a particular product with the properties described in the product specification is suitable for use in a particular application. Parameters provided in datasheets and/or specifications may vary in different applications and performance may vary over time. All operating parameters, including typical parameters, must be validated for each customer application by the customer's technical experts. Product specifications do not expand or otherwise modify Vishay's terms and conditions of purchase, including but not limited to the warranty expressed therein.

Except as expressly indicated in writing, Vishay products are not designed for use in medical, life-saving, or life-sustaining applications or for any other application in which the failure of the Vishay product could result in personal injury or death. Customers using or selling Vishay products not expressly indicated for use in such applications do so at their own risk. Please contact authorized Vishay personnel to obtain written terms and conditions regarding products designed for such applications.

No license, express or implied, by estoppel or otherwise, to any intellectual property rights is granted by this document or by any conduct of Vishay. Product names and markings noted herein may be trademarks of their respective owners.

Material Category Policy

Vishay Intertechnology, Inc. hereby certifies that all its products that are identified as RoHS-Compliant fulfill the definitions and restrictions defined under Directive 2011/65/EU of The European Parliament and of the Council of June 8, 2011 on the restriction of the use of certain hazardous substances in electrical and electronic equipment (EEE) - recast, unless otherwise specified as non-compliant.

Please note that some Vishay documentation may still make reference to RoHS Directive 2002/95/EC. We confirm that all the products identified as being compliant to Directive 2002/95/EC conform to Directive 2011/65/EU.

Vishay Intertechnology, Inc. hereby certifies that all its products that are identified as Halogen-Free follow Halogen-Free requirements as per JEDEC JS709A standards. Please note that some Vishay documentation may still make reference to the IEC 61249-2-21 definition. We confirm that all the products identified as being compliant to IEC 61249-2-21 conform to JEDEC JS709A standards.