

## RF Spiral Inductor for Wire Bonded Assemblies

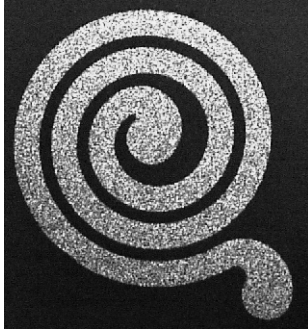

PSC series RF spiral inductors are designed for RF circuits that require wire bondable components. High precision equivalent circuit modeling enables accurate computer simulation of component performance. Additional values and form factors available upon request.

### FEATURES

- Wire bond assembly
- Small size: 45 mils x 45 mils x 10 mils
- Low DCR, high Q
- Low parasitic capacitance, high SRF



### APPLICATIONS

- RF choking for DC biasing
- RF tuning circuits
- Lumped element filters

STANDARD SPECIFICATIONS	
PARAMETER	SPECIFICATIONS
Substrate Material	Alumina 99.6 %
Conductor Material	Gold
Conductor Thickness	5 $\mu\text{m} \pm 10\%$
Inductance Range	1 nH to 100 nH
Tolerance <sup>(1)</sup>	$\pm 20\%$
Maximum Power Handling	250 mW
Operating Temperature	- 55 °C to + 125 °C
Storage Temperature	- 55 °C to + 125 °C
Bond Pad Diameter <sup>(2)</sup>	6 mil

#### Notes

(1) Main source of value tolerance is due to variation in wire bonds. See "text fixture" section below.

(2) Bond pad geometry can be modified upon request.

RF CHARACTERISTICS								
PART NUMBER	INDUCTANCE VALUE (nH)		DCR ( $\Omega$ )	IN-CIRCUIT INDUCTANCE VALUE (nH) <sup>(1)</sup>	IN-CIRCUIT DCR ( $\Omega$ ) <sup>(1)</sup>	Q		SRF (GHz)
	250 MHz	1000 MHz				250 MHz	1000 MHz	
PSC3500C	3.5	3.5	0.26	6	0.36	8	14	10.2
PSC1050B	10.5	10.5	0.9	12	1	10	16	5.5
PSC1250B	12.5	12.5	0.9	15	1	12	18	5.0
PSC1800B	18	18	1.25	20.5	1.35	13	15	4.2
PSC4500B	45	50	3.4	47.5	3.5	13	8	2.4

#### Note

(1) Including the added inductance and resistance of typical bond wires. See equivalent circuit section.

DIMENSIONS in inches [millimeters]				
	LENGTH	WIDTH	THICKNESS	BOND PAD DIAMETER
	0.045 ± 0.002 [1.143 ± 0.051]	0.045 ± 0.002 [1.143 ± 0.051]	0.010 ± 0.001 [0.254 ± 0.0254]	0.006 [0.152]

GLOBAL PART NUMBER INFORMATION																
Global Part Number: PSC4000CL4A1GNHW1																
Global Part Number Description: PSC 4 nH 25 % 45 x 45 x 10 Au None H W1																
P	S	C	4	0	0	0	C	L	4	A	1	G	N	H	W	1
MODEL	INDUCTANCE (nH)	INDUCTANCE MULTIPLIER CODE	TOLERANCE CODE	SIZE	SUBSTRATE	THICKNESS (mil)	TERMINATION	BACK METAL	TEST CLASS	PACKAGING CODE						
PSC	The first 4 digits are significant figures of inductance	C = 0.001 B = 0.01 A = 0.1	M = 20 % L = 25 %	4 = 45 x 45	A = Alumina	1 = 10	G = Au	G = Au N = None	H = Class H K = Class K	W1 = Waffle pack, 1 min, 1 mult TS = Tape and Reel 100 min, 1 mult						

**EQUIVALENT CIRCUIT**

The inductor's spiral trace presents a substantial amount of series resistance, and the close spacing of the spiral turns presents measurable amounts of stray capacitance that interact with the inductive characteristics.

A useful tool commonly used to model the behavior of electronic components at high frequency is the equivalent circuit model. While the equivalent circuit model accurately predicts the reactive part of the total impedance, it fails to determine the real part of the response at high frequency. This is due to the fact that the model does not include skin and proximity effects that significantly increase the real part of the impedance as the frequency rises.

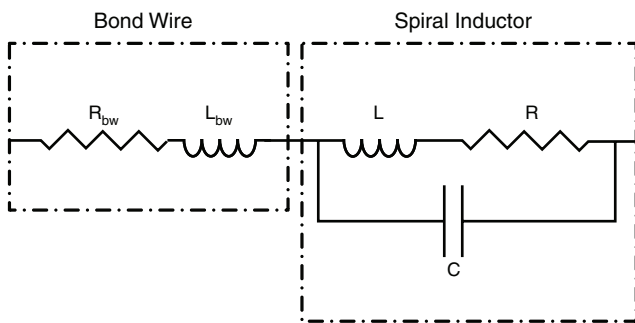

- L: Desired inductance
- R: Parasitic self resistance
- C: Parasitic shunt capacitance
- R<sub>bw</sub>: Bond wire self resistance
- L<sub>bw</sub>: Parasitic bond wire inductance

Fig. 1 - Equivalent Circuit

The equivalent circuit values are presented in the table below:

EQUIVALENT CIRCUIT MODEL 2				
INDUCTANCE VALUE L (nH)	DCR R (Ω)	SHUNT CAP. C (fF)	TYP. R <sub>bw</sub> <sup>(1)</sup> (Ω)	TYP. L <sub>bw</sub> <sup>(1)</sup> (nH)
3.5	0.26	71	0.1	2.5
10.5	0.9	80	0.1	2.5
12.5	0.9	81	0.1	2.5
18	1.25	84	0.1	2.5
45	3.4	92	0.1	2.5

**Note**

<sup>(1)</sup> Typical bond wires are approximated as being 1.25 mil in diameter gold, totaling a length of 3 mm. The resistance listed above includes the added effect of the bond wire adhesion to the substrate and component.

**COMPONENT PERFORMANCE**

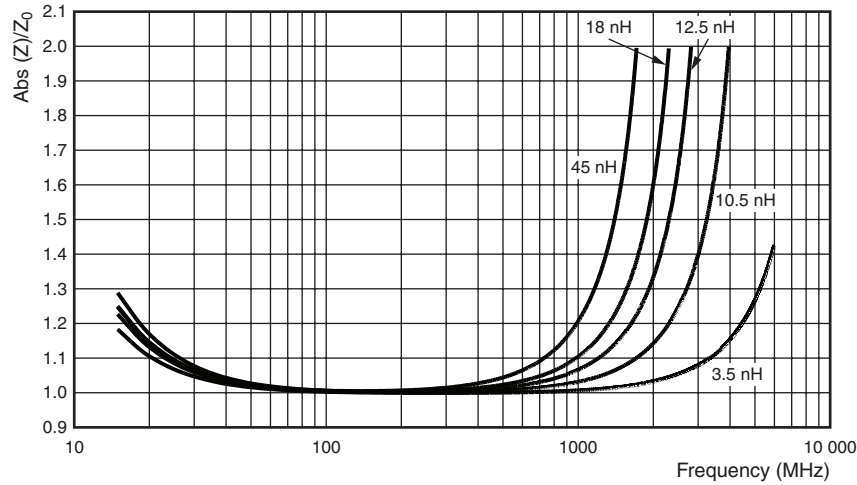

Fig. 2 - Relative Impedance vs. Frequency

**LAYOUT CONSIDERATIONS**

The RF spiral inductor is electrically connected to the circuit by wire bonds. All wire bonds add parasitic inductance and resistance, as shown in Figure 1.

It is important to note that setup variations might affect the performance of the component. Special care must be given to minimize these effects by careful design of the component host circuit board. The following aspects should be considered:

- Bond wire length should be minimized. The bond wire added inductance can be roughly estimated at 0.75 nH per mm of 1.25 mil diameter gold wire.
- Any ground plane directly under the component will increase the parasitic shunt capacitance. This will cause self-resonance at lower frequencies.
- The epoxy used to attach the component is the limiting factor in power handling. For applications that require high power handling it is recommended to use high temperature epoxy and to ensure adequate heat sinking.



## Disclaimer

All product specifications and data are subject to change without notice.

Vishay Intertechnology, Inc., its affiliates, agents, and employees, and all persons acting on its or their behalf (collectively, "Vishay"), disclaim any and all liability for any errors, inaccuracies or incompleteness contained herein or in any other disclosure relating to any product.

Vishay disclaims any and all liability arising out of the use or application of any product described herein or of any information provided herein to the maximum extent permitted by law. The product specifications do not expand or otherwise modify Vishay's terms and conditions of purchase, including but not limited to the warranty expressed therein, which apply to these products.

No license, express or implied, by estoppel or otherwise, to any intellectual property rights is granted by this document or by any conduct of Vishay.

The products shown herein are not designed for use in medical, life-saving, or life-sustaining applications unless otherwise expressly indicated. Customers using or selling Vishay products not expressly indicated for use in such applications do so entirely at their own risk and agree to fully indemnify Vishay for any damages arising or resulting from such use or sale. Please contact authorized Vishay personnel to obtain written terms and conditions regarding products designed for such applications.

Product names and markings noted herein may be trademarks of their respective owners.