

DB151S THRU DB157S

List

List..... 1

Package outline..... 2

Features..... 2

Mechanical data..... 2

Maximum ratings 2

Rating and characteristic curves..... 3

Pinning information..... 4

Marking..... 4

Suggested solder pad layout..... 4

Packing information..... 5

Reel packing and tube packing..... 6

Suggested thermal profiles for soldering processes..... 6

High reliability test capabilities..... 7

深圳FMS Kinter 131 6803 0058

DB151S THRU DB157S

1.5A Miniature Glass Passivated Single-Phase Surface Mount Bridge Rectifiers-50-1000V

Features

- Surge overload ratings to 50 amperes peak.
- Save space on printed circuit board.
- Ideal for automated replacement.
- Reliable low cost construction utilizing molded plastic technology results in inexpensive product.
- Glass passivated chip junctions.
- Lead-free parts meet RoHS requirements.
- UL recognized file # E321971
- Suffix "-H" indicates Halogen free parts, ex. DB151S-H.

Mechanical data

- Epoxy:UL94-V0 rated flame retardant
- Case : Molded plastic, DBS
- Terminals : Solder plated, solderable per MIL-STD-750, Method 2026
- Polarity : marked on body
- Mounting Position : Any
- Weight : Approximated 0.50 gram

Package outline

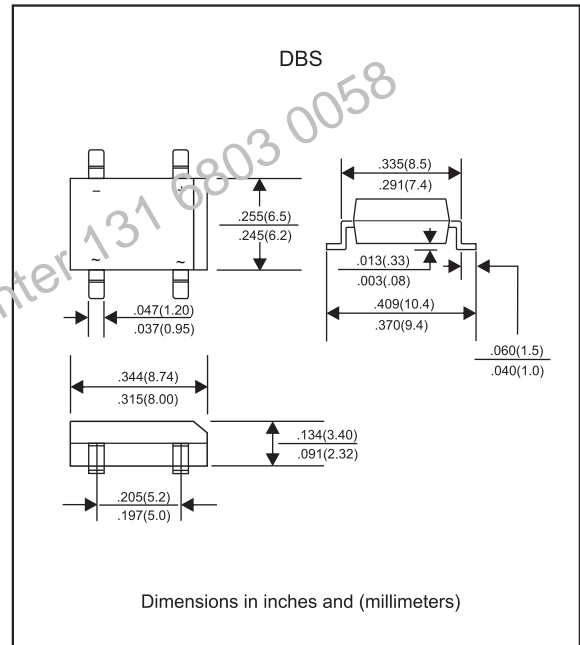

Maximum ratings and Electrical Characteristics (AT $T_A=25^{\circ}\text{C}$ unless otherwise noted)

PARAMETER	CONDITIONS	Symbol	MIN.	TYP.	MAX.	UNIT
Forward rectified current	See Fig.1	I_o			1.5	A
Forward surge current	8.3ms single half sine-wave superimposed on rate load (JEDEC methode)	I_{FSM}			50	A
Reverse current	$V_R = V_{RRM} \quad T_J = 25^{\circ}\text{C}$	I_R			10	uA
	$V_R = V_{RRM} \quad T_J = 125^{\circ}\text{C}$				500	
Diode junction capacitance	f=1MHz and applied 4V DC reverse voltage	C_J		25		pF
Storage temperature		T_{STG}	-65		+175	$^{\circ}\text{C}$

SYMBOLS	V_{RRM}^{*1} (V)	V_{RMS}^{*2} (V)	V_R^{*3} (V)	V_F^{*4} (V)	Operating temperature T_{Ji} ($^{\circ}\text{C}$)
DB151S	50	35	50	1.10	-55 to +150
DB152S	100	70	100		
DB153S	200	140	200		
DB154S	400	280	400		
DB155S	600	420	600		
DB156S	800	560	800		
DB157S	1000	700	1000		

- *1 Repetitive peak reverse voltage
- *2 RMS voltage
- *3 Continuous reverse voltage
- *4 Maximum forward voltage @ $I_F=1.5\text{A}$

Rating and characteristic curves (DB151S THRU DB157S)

FIG.1-FORWARD CURRENT DERATING CURVE

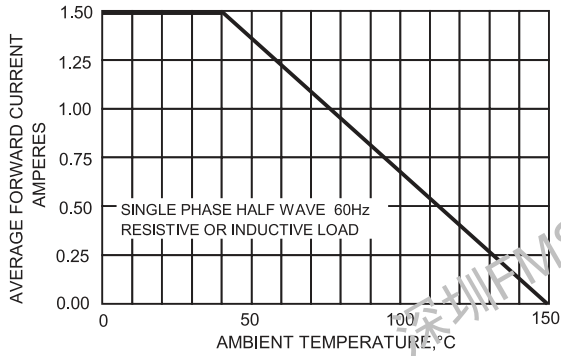

FIG.2-MXIMUM NON-REPETITIVE SURGE CURRENT

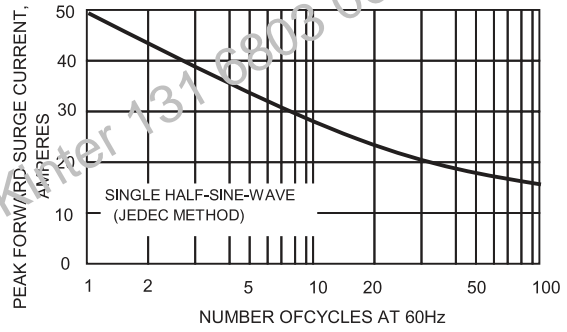

FIG.3-TYPICAL JUNCTION CAPACITANCE

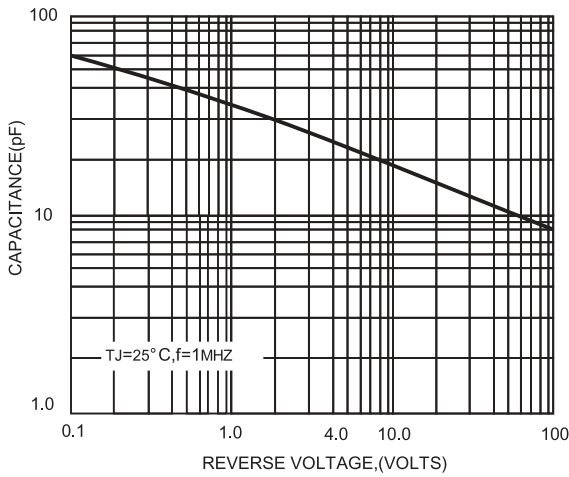

FIG.4-TYPICAL FORWARD CHARACTERISTICS

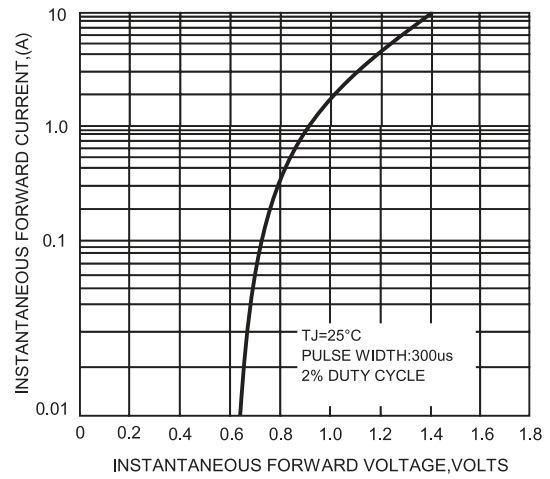
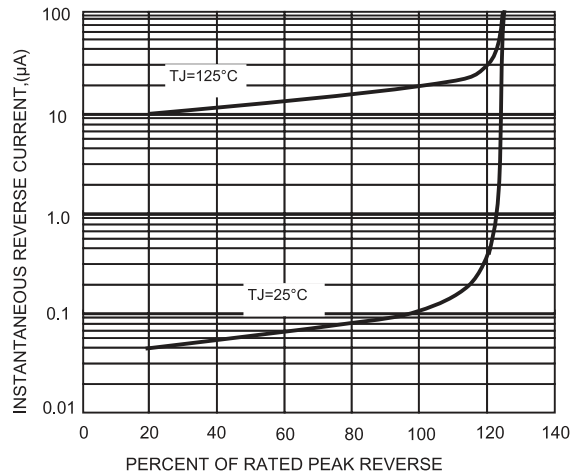
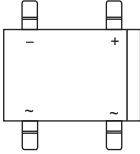
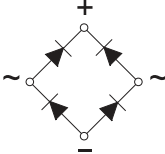

FIG.5-TYPICAL REVERSE CHARACTERISTICS



DB151S THRU DB157S

Pinning information

Simplified outline	Symbol
	

Marking

Type number	Marking code
DB151S	DB151S
DB152S	DB152S
DB153S	DB153S
DB154S	DB154S
DB155S	DB155S
DB156S	DB156S
DB157S	DB157S

Suggested solder pad layout

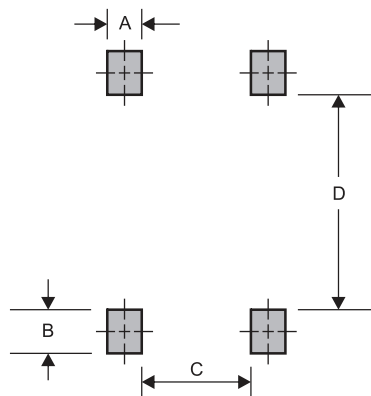

Dimensions in inches and (millimeters)

PACKAGE	A	B	C	D
DBS	0.059 (1.50)	0.047 (1.20)	0.157 (4.00)	0.291 (7.40)

DB151S THRU DB157S

Packing information

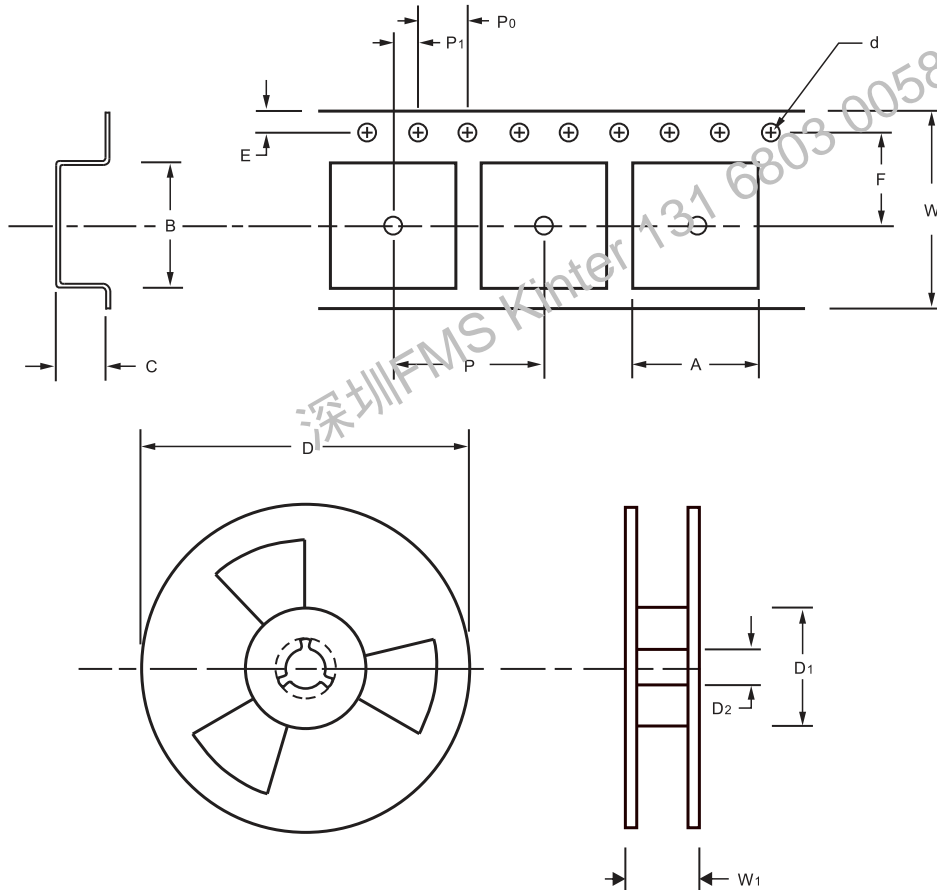

unit:mm

Item	Symbol	Tolerance	DBS
Carrier width	A	0.1	8.64
Carrier length	B	0.1	10.41
Carrier depth	C	0.1	3.50
Sprocket hole	d	0.1	1.50
13" Reel outside diameter	D	2.0	330.00
13" Reel inner diameter	D1	min	50.00
7" Reel outside diameter	D	2.0	-
7" Reel inner diameter	D1	min	-
Feed hole diameter	D2	0.5	13.00
Sprocket hole position	E	0.1	1.75
Punch hole position	F	0.1	7.50
Punch hole pitch	P	0.1	12.00
Sprocket hole pitch	P0	0.1	4.00
Embossment center	P1	0.1	2.00
Overall tape thickness	T	0.1	0.30
Tape width	W	0.3	16.00
Reel width	W1	1.0	22.00

Note: Devices are packed in accordance with EIA standard RS-481-A and specifications listed above.

DB151S THRU DB157S

Reel packing and tube packing

PACKAGE	REEL SIZE	REEL (pcs)	COMPONENT SPACING (m/m)	BOX (pcs)	INNER BOX (m/m)	REEL DIA, (m/m)	CARTON SIZE (m/m)	CARTON (pcs)	APPROX. GROSS WEIGHT (kg)
DBS	13"	1000	12.0	2000	337*337*37	330	350*330*360	12,000	12.0

PACKAGE	TUBE (pcs)	TUBE SIZE (m/m)	BOX (pcs)	INNER BOX (m/m)	CARTON SIZE (m/m)	CARTON (pcs)	APPROX. GROSS WEIGHT (kg)
DBS	50	452*13.9*5.8	5000	450*145*73	470*240*310	30,000	21.0

Suggested thermal profiles for soldering processes

- 1.Storage environment: Temperature=-5°C~40°C Humidity=55%±25%
- 2.Reflow soldering of surface-mount devices

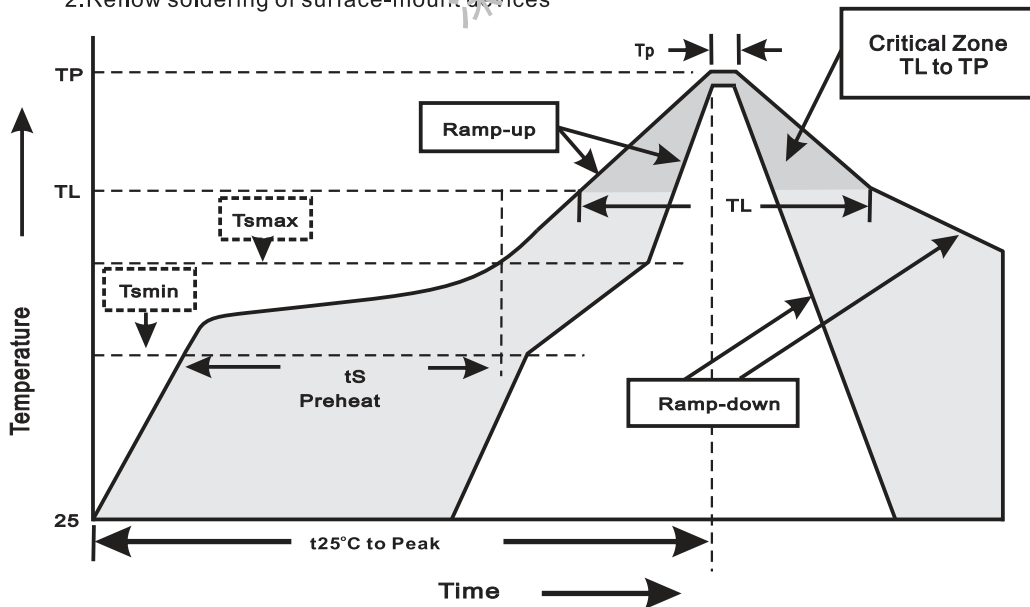

3.Reflow soldering

Profile Feature	Soldering Condition
Average ramp-up rate(T _L to T _P)	<3°C/sec
Preheat -Temperature Min(T _{smin}) -Temperature Max(T _{smax}) -Time(min to max)(t _s)	150°C 200°C 60~120sec
T _{smax} to T _L -Ramp-upRate	<3°C/sec
Time maintained above: -Temperature(T _L) -Time(t _L)	217°C 60~260sec
Peak Temperature(T _P)	255°C-0/+5°C
Time within 5°C of actual Peak Temperature(t _P)	10~30sec
Ramp-down Rate	<6°C/sec
Time 25°C to Peak Temperature	<6minutes

DB151S THRU DB157S**High reliability test capabilities**

Item Test	Conditions	Reference
1. Solder Resistance	at 260±5°C for 10±2sec. immerse body into solder 1/16"±1/32"	MIL-STD-750D METHOD-2031
2. Solderability	at 245±5°C for 5 sec.	MIL-STD-202F METHOD-208
3. High Temperature Reverse Bias	$V_R=80\%$ rate at $T_J=150^\circ\text{C}$ for 168 hrs.	MIL-STD-750D METHOD-1038
4. Forward Operation Life	Rated average rectifier current at $T_A=25^\circ\text{C}$ for 500hrs.	MIL-STD-750D METHOD-1027
5. Intermittent Operation Life	$T_A=25^\circ\text{C}$, $I_F=I_O$ On state: power on for 5 min. off state: power off for 5 min. on and off for 500 cycles.	MIL-STD-750D METHOD-1036
6. Pressure Cooker	$15P_{SIG}$ at $T_A=121^\circ\text{C}$ for 4 hrs.	JESD22-A102
7. Temperature Cycling	-55°C to +125°C dwelled for 30 min. and transferred for 5min. total 10 cycles.	MIL-STD-750D METHOD-1051
8. Thermal Shock	0°C for 5 min. rise to 100°C for 5 min. total 10 cycles.	MIL-STD-750D METHOD-1056
9. Forward Surge	8.3ms single half sine-wave superimposed on rated load, one surge.	MIL-STD-750D METHOD-4066-2
10. Humidity	at $T_A=85^\circ\text{C}$, RH=85% for 1000hrs.	MIL-STD-750D METHOD-1021
11. High Temperature Storage Life	at 175°C for 1000 hrs.	MIL-STD-750D METHOD-1031