

# X-Band Motion Sensor

## Features

TMS400 is X-band Doppler motion sensor to detect motion. It consists of DR(dielectric resonator) oscillator, passive diode and patch antennas and provides most reliable solution in motion detection.

## Applications

- Intrusion alarm
- Automatic door
- Obstruction alarm system
- Velocity measurement
- Automatic light control-energy saving
- System air-conditioner-zone control

### Picture

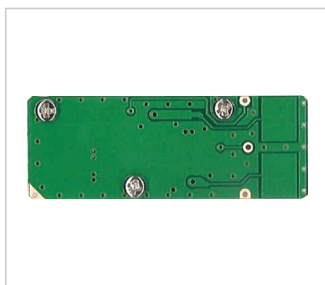

E-axis →

 H-axis  
 ↓

### Antenna beam pattern

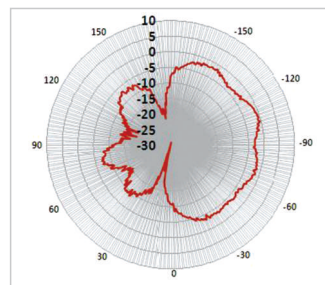

E-axis

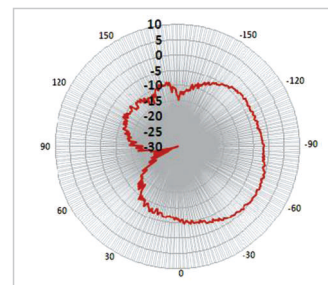

H-axis

## Electrical Specifications

Parameters		Min.	Typ.	Max.	Unit	Condition
CW	Frequency	10,525 ± 12.5			MHz	Over Temp.
	Output Power (EIRP)		10		dBm	
	Power Supply	4.75	5	5.25	V	
	Current Consumption	30		60	mA	CW
	Settling time			6	μs	
	Noise			10	μVrms	3~80 Hz
	Received Signal			20	mVp-p	max
	3dB Antenna Beam Width - E-axis		74		°	
	3dB Antenna Beam Width - H-axis		85		°	
	Operating temp.	-20		+55	°C	
	Storage temp.	-30		+70	°C	
	Size	51.5 x 19.2 x 9.0			mm <sup>3</sup>	
Pulse Operation	Pulse Width	5			μs	
	Duty Cycle	1			%	
	Average Current		2		mA	@5% duty

Warning : The specifications can be changed without any notice.

# X-Band Motion Sensor

## Dimension

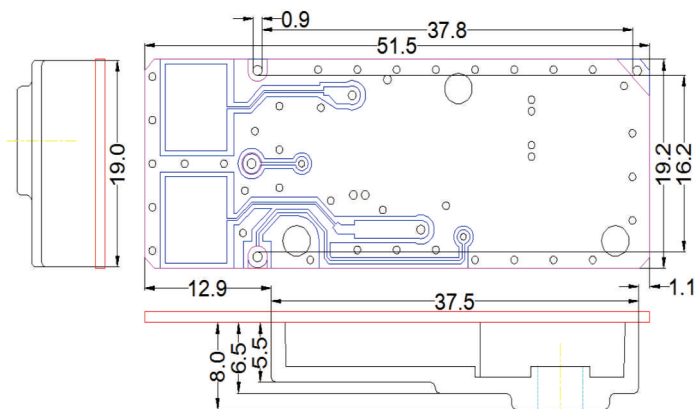

## Pin Description

#	Pin Name	Explanation
1	VDD	Power, +5V
2	IF	Output
3	GND	Ground
4	GND	Ground

## Application Circuit Example

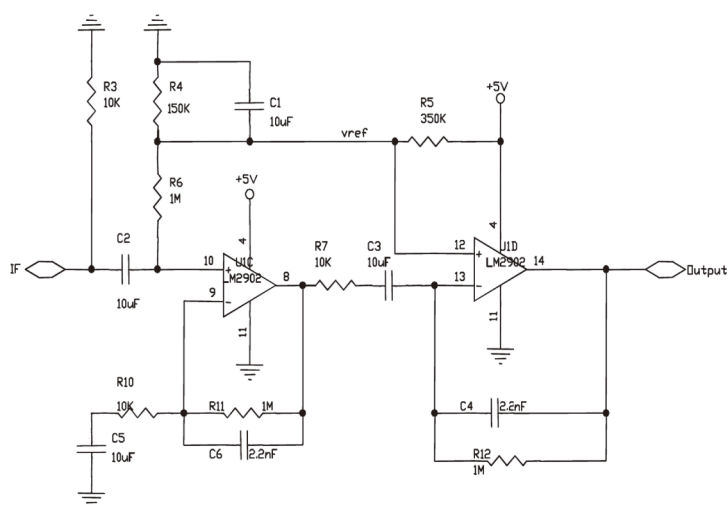

## Block Diagram

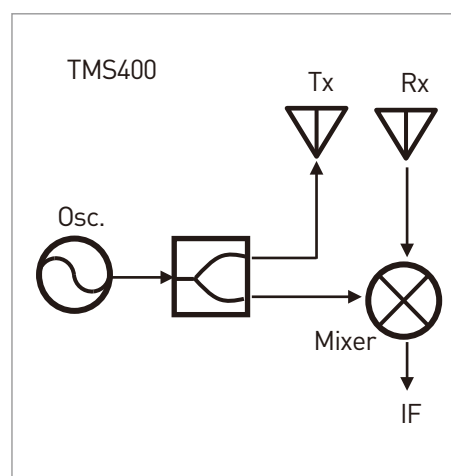

Warning : To avoid a fatal damage, it should be carefully handled and installed under ESD protection condition.