

Product Description

The PE4140 is an ultra-high linearity, passive broadband Quad MOSFET array with high dynamic range performance capable of operation beyond 6.0 GHz. This quad array operates with differential signals at all ports (RF, LO, IF), allowing mixers to be built that use LO powers from -7 dBm to +20 dBm. Typical applications range from frequency up/down-conversion to phase detection for Cellular/PCS Base Stations, Wireless Broadband Communications and STB/Cable modems.

The PE4140 is manufactured in Peregrine's patented Ultra Thin Silicon (UTSi®) CMOS process, offering the performance of GaAs with the economy and integration of conventional CMOS.

Figure 1. Functional Schematic Diagram

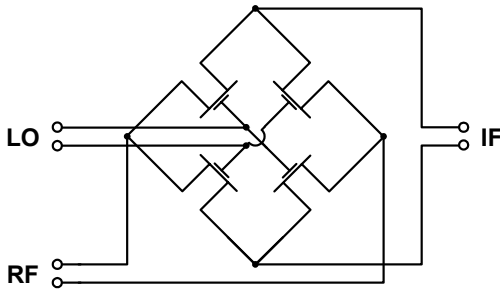

Ultra-High Linearity Broadband Quad MOSFET Array

Features

- Ultimate Quad MOSFET array
- Ultra-high linearity, broadband performance beyond 6.0 GHz
- Ideal for mixer applications
- Up/down conversion
- Low conversion loss
- High LO Isolation
- Packaged in small 3x3mm MLPM

Figure 2. Package Type

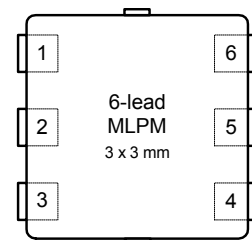

Table 1. AC and DC Electrical Specifications @ +25 °C

Symbol	Characteristics	Min	Typ	Max	Units	Test Conditions
F_{TYP}	Operating Frequency Range ¹	DC	6.0		GHz	
V_{DS}	Drain-Source Voltage	260	320	380	mV	$V_{GS} = +3V, I_{DS} = 40 \text{ mA}$
$V_{DS \text{ Match}}$	Drain-Source Voltage Match		12	40	mV	
V_T	Threshold Voltage		-100		mV	$V_{DS} = 0.1V$; per ASTM F617-00
R_{DS}	Drain-Source 'ON' Resistance	6.5	7.75	9.5	Ω	$V_{GS} = +3V, I_{DS} = 40 \text{ mA}$

Note 1: Typical untested operating frequency range of Quad MOSFET transistors.

Figure 3. Pin Configuration

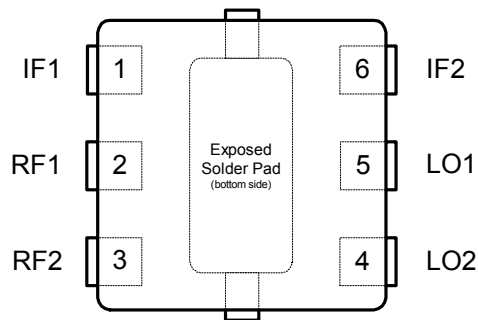

Table 2. Pin Descriptions

Pin No.	Pin Name	Description
1	IF1	IF Output Connection (Drain)
2	RF1	RF Input Connection (Source)
3	RF2	RF Input Connection (Source)
4	LO2	LO Input Connection (Gate)
5	LO1	LO Input Connection (Gate)
6	IF2	IF Output Connection (Drain)

Table 3. Absolute Maximum Ratings

Symbol	Parameter/Conditions	Min	Max	Units
T_{ST}	Storage temperature range	-65	150	°C
T_{OP}	Operating temperature range	-40	85	°C
V_{DC+AC}	Maximum DC plus peak AC voltage across Drain-Source		±3.3	V
V_{DC+AC}	Maximum DC plus peak AC voltage across Gate-Drain or Gate-Source		±4.2	V
V_{ESD}	ESD Sensitive Device		250	V

Electrostatic Discharge (ESD) Precautions

This MOSFET device has minimally protected inputs and is highly susceptible to ESD damage. When handling this UTSi device, observe the same precautions that you would use with other ESD-sensitive devices.

Latch-Up Avoidance

Unlike conventional CMOS devices, UTSi CMOS devices are immune to latch-up.

Device Description

The PE4140 passive broadband Quad MOSFET array is designed for use in up-conversion and down-conversion applications for high performance systems such as cellular infrastructure equipment and STB/CATV systems.

The PE4140 is an ideal mixer core for a wide range of mixer products, including module level solutions that incorporate baluns or other single-ended matching structures enabling three-port operation.

The performance level of this passive mixer is made possible by the very high linearity afforded by Peregrine's UTSi CMOS process.

Marking

Packaged devices are marked with part number "4140", date code and lot code.

Figure 4. Typical Schematic for a PCS Application

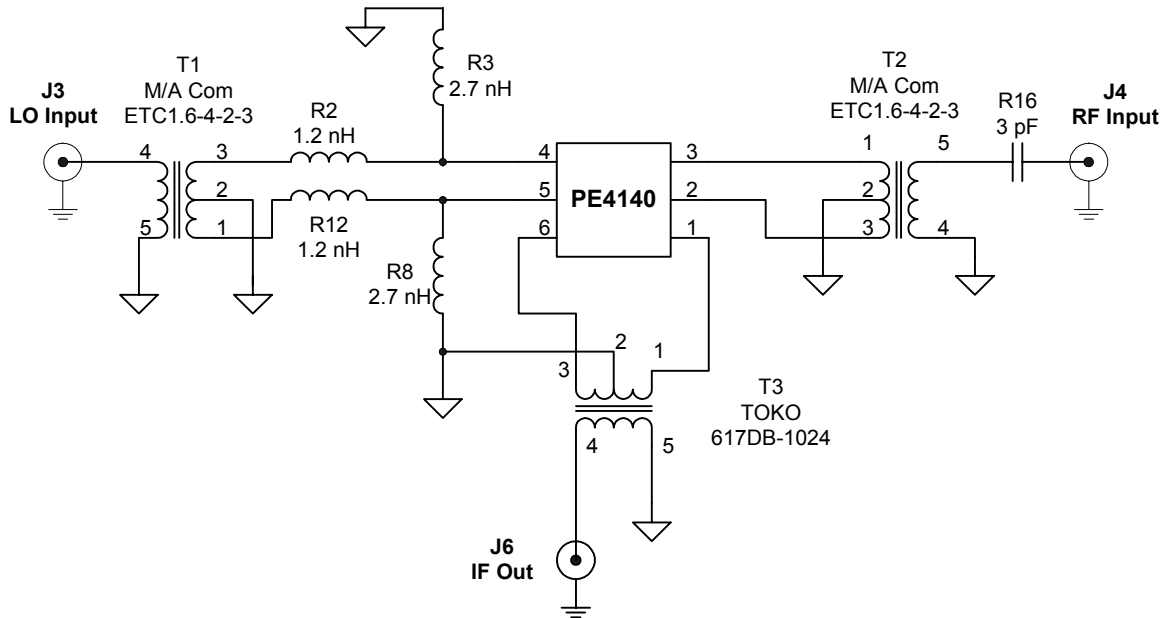

Table 4. Typical Performance in a PCS Application @ +25 °C

Parameter	Minimum	Typical	Maximum	Units
Frequency Range**				
LO	1630	--	2130	MHz
RF	1700	--	2200	MHz
IF		70		MHz
Conversion Loss** (Includes balun losses)		8.5		dB
Isolation**				
LO-RF		36		dB
LO-IF		26		dB
Input IP3**		32		dBm
Input 1 dB Compression**		22		dBm

** Data taken on an Evaluation Board narrow-band tuned to cover the PCS band, IF = 73MHz low-side, LO drive = 17dBm.

Typical Performance Plots in a PCS Application @ +25 °C (LO=17dBm, IF=73MHz Low-side)

Figure 5. IIP3 vs. Frequency

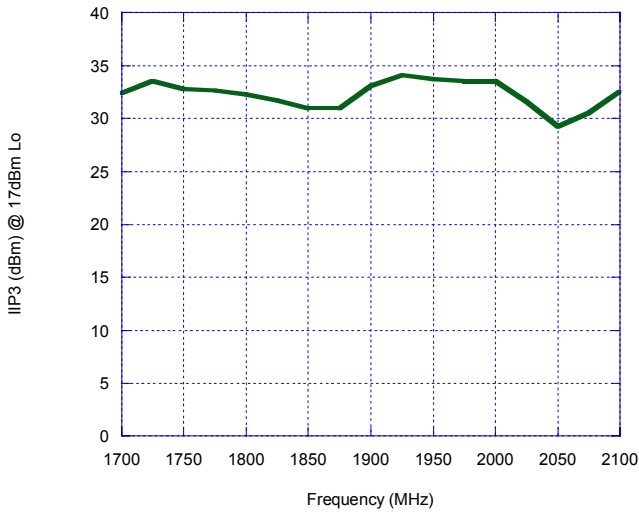

Figure 6. Conversion Loss vs. Frequency

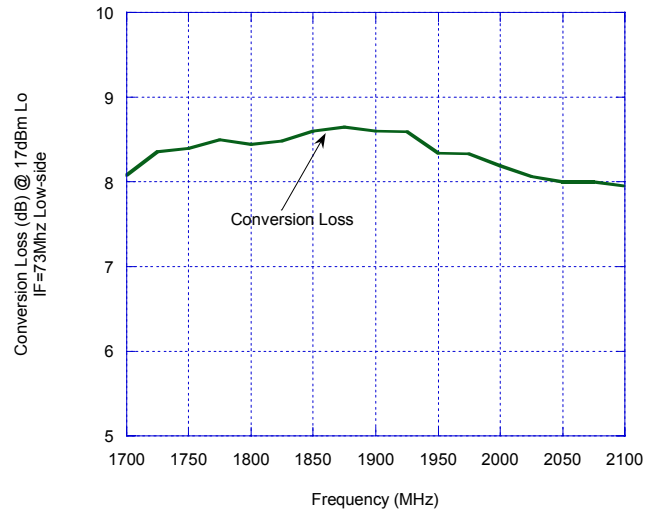

Figure 7. LO-RF & LO-IF Isolation

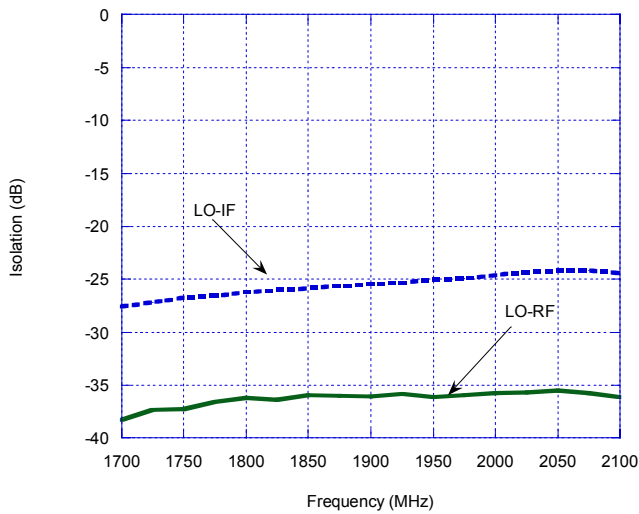
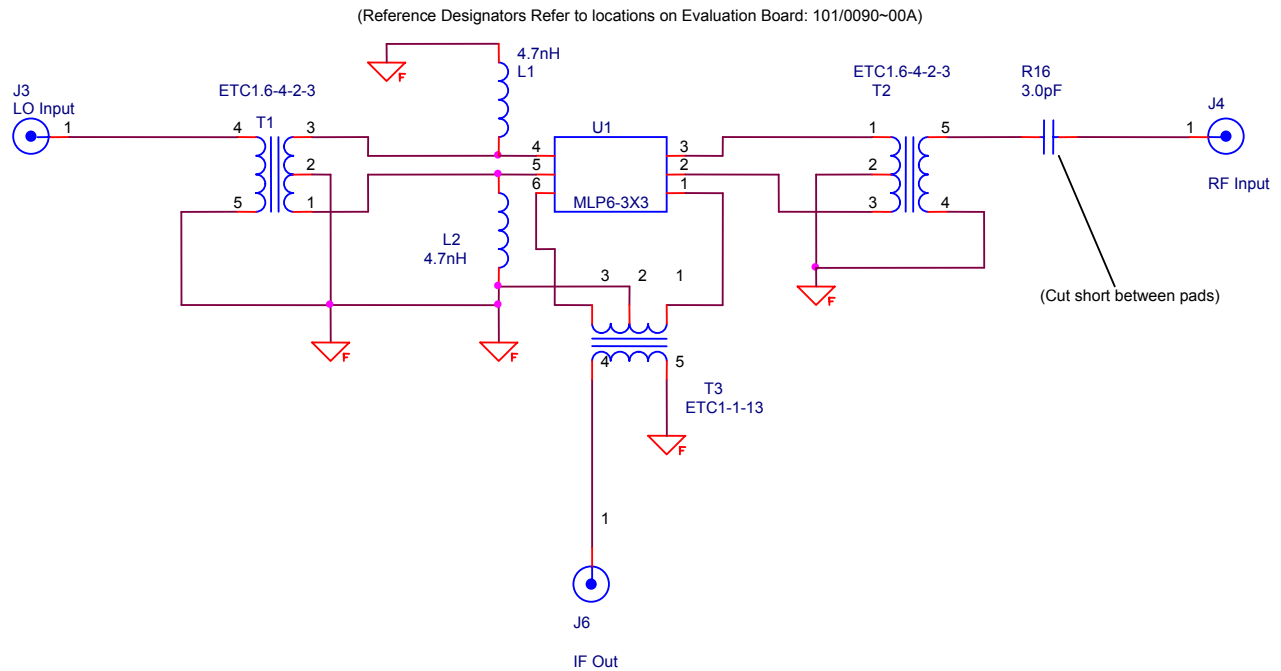

Figure 8. Typical Schematic for a CATV Application



Note: L1 and L2 provide LO port matching for optimum performance. Typical gate capacitance is approximately 2.5 pF.

Table 5. Typical Performance in a CATV Application @ +25 °C

Parameter	Minimum	Typical	Maximum	Units
Frequency Range**				
LO	1116	--	1926	MHz
RF	54	--	864	MHz
IF		1062		MHz
Conversion Loss** (Includes balun losses)		6.5		dB
Isolation**				
LO-RF		40		dB
LO-IF		28		dB
Input IP3**		23		dBm
Input 1 dB Compression**		13		dBm

** Data taken on an Evaluation Board tuned for a broadband CATV application, IF = 1062MHz, RF drive = -5dBm, LO drive = 10dBm.

Typical Performance Plots in a CATV Application @ +25 °C

Figure 9. IIP3 vs. Frequency

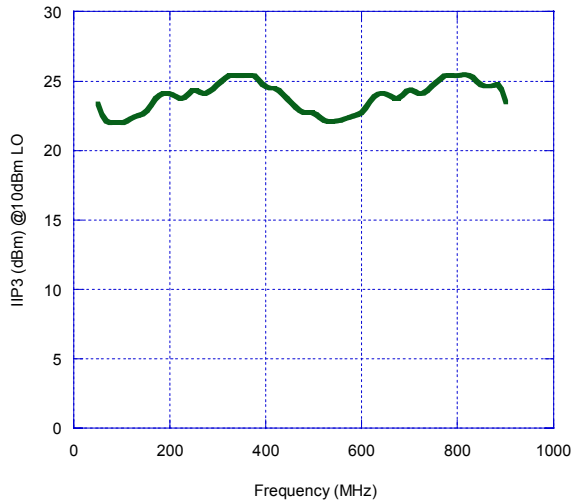

Figure 10. Conversion Loss vs. Frequency

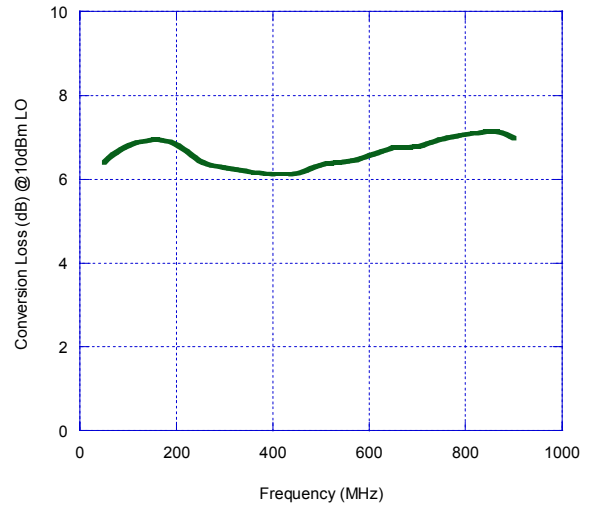

Figure 11. LO-RF & LO-IF Isolation

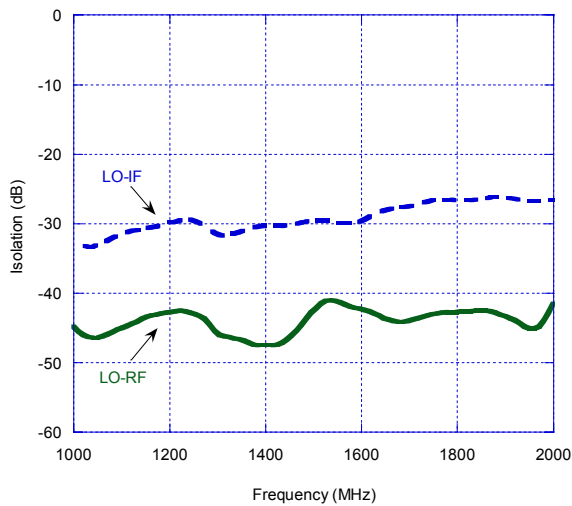
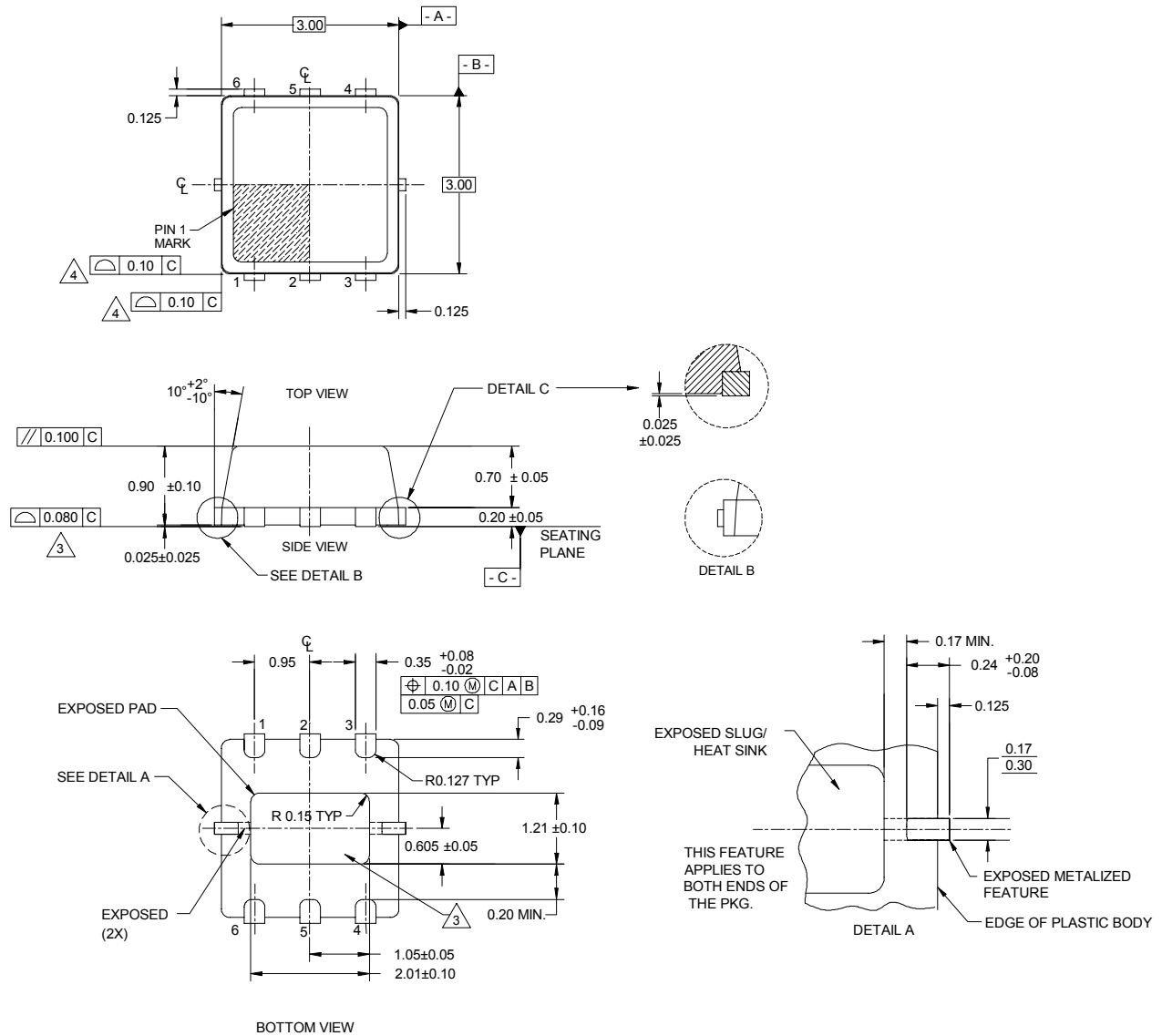

Figure 12. Package Drawing

6-lead MLPM



1. DIMENSIONS AND TOLERANCES ARE PER ANSI Y14.5
2. DIMENSIONS ARE IN MILLIMETERS, ANGLES ARE IN DEGREES.
3. COPLANARITY APPLIES TO EXPOSED HEAT SLUG AS WELL AS THE TERMINALS.
4. PROFILE TOLERANCE APPLIES TO PLASTIC BODY ONLY.

Table 6. Ordering Information

Order Code	Part Marking	Description	Package	Shipping Method
PE4140-01	4140	PE4140-06MLP3x3-12800F	6-lead 3x3 MLPM	12800 units / Canister
PE4140-02	4140	PE4140-06MLP3x3-3000C	6-lead 3x3 MLPM	3000 units / T&R
PE4140-00	PE4140-EK	PE4140-06MLP3x3-EK	Evaluation Kit	1 / box

Sales Offices

United States

Peregrine Semiconductor Corp.

6175 Nancy Ridge Drive
San Diego, CA 92121
Tel 1-858-455-0660
Fax 1-858-455-0770

Japan

Peregrine Semiconductor K.K.

5A-5, 5F Imperial Tower
1-1-1 Uchisaiwaicho, Chiyoda-ku
Tokyo 100-0011 Japan
Tel: 03-3507-5755
Fax: 03-3507-5601

Europe

Peregrine Semiconductor Europe

Bâtiment Maine
13-15 rue des Quatre Vents
F- 92380 Garches
Tel 33-1-47-41-91-73
Fax 33-1-47-41-91-73

For a list of representatives in your area, please refer to our Web site at: <http://www.peregrine-semi.com>

Data Sheet Identification

Advance Information

The product is in a formative or design stage. The data sheet contains design target specifications for product development. Specifications and features may change in any manner without notice.

Preliminary Specification

The data sheet contains preliminary data. Additional data may be added at a later date. Peregrine reserves the right to change specifications at any time without notice in order to supply the best possible product.

Product Specification

The data sheet contains final data. In the event Peregrine decides to change the specifications, Peregrine will notify customers of the intended changes by issuing a PCN (Product Change Notice).

The information in this data sheet is believed to be reliable. However, Peregrine assumes no liability for the use of this information. Use shall be entirely at the user's own risk.

No patent rights or licenses to any circuits described in this data sheet are implied or granted to any third party.

Peregrine's products are not designed or intended for use in devices or systems intended for surgical implant, or in other applications intended to support or sustain life, or in any application in which the failure of the Peregrine product could create a situation in which personal injury or death might occur. Peregrine assumes no liability for damages, including consequential or incidental damages, arising out of the use of its products in such applications.

Peregrine products are protected under one or more of the following U.S. patents: 6,090,648; 6,057,555; 5,973,382; 5,973,363; 5,930,638; 5,920,233; 5,895,957; 5,883,396; 5,864,162; 5,863,823; 5,861,336; 5,663,570; 5,610,790; 5,600,169; 5,596,205; 5,572,040; 5,492,857; 5,416,043. Other patents are pending.

Peregrine, the Peregrine logotype, Peregrine Semiconductor Corp., and UTSi are registered trademarks of Peregrine Semiconductor Corporation. Copyright © 2003 Peregrine Semiconductor Corp. All rights reserved.