

**DESIGNED & DIMENSIONED
IN MILLIMETERS [INCHES]**

BNC7-P-C-XX-ST-CA3

GENDER
-P: PLUG

TYPE
-C: CABLE

TERMINATION
-CA3: CABLE (RG179)

ORIENTATION
-ST: STRAIGHT

PLATING SPECIFICATION
-MN: MEDIUM GOLD/NICKEL (SEE NOTE 7)
(SMA-FER-001-N)
(BNC7-PIN-002-M)
(SUB-BNC7-P-C-N-ST-CA3)

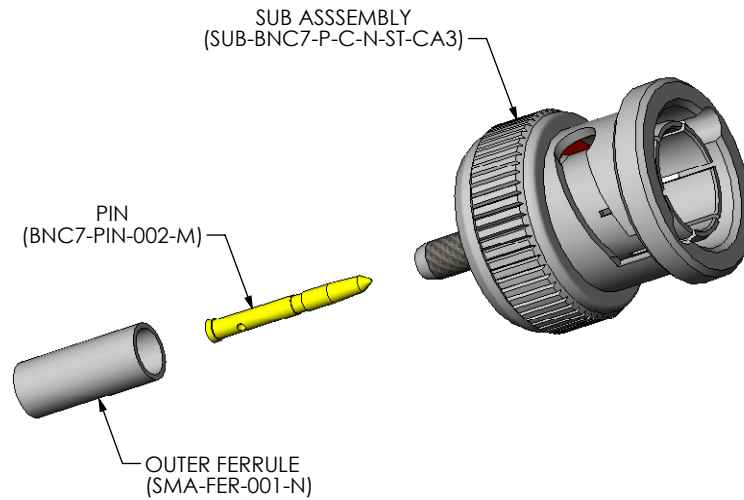
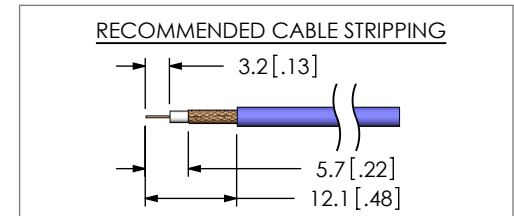



FIG. 1
(BNC7-P-C-MN-ST-CA3 SHOWN)



NOTES:

1. $\text{\textcircled{C}}$ REPRESENTS A CRITICAL DIMENSION.
2. CENTER CONTACT PUSHOUT FORCE: 26.69 N [6 LB] MIN.
3. SEE SHEET 3 FOR TERMINATION INFORMATION.
4. COMPONENTS TO BE SHIPPED UNASSEMBLED.
5. SAMPLE ORDERS: TO BE PACKAGED IN INDIVIDUAL KIT FORM, PRODUCTION ORDERS: EACH COMPONENT TO BE BULK PACKAGED.
6. RoHS COMPLIANT.
7. PLATING:
-N: 0.00254[0.000100] (MIN) NICKEL
-M: 0.00025[0.000010] (MIN) GOLD OVER 0.00127[0.000050] (MIN) NICKEL

F:\DWG\MISC\MKTG\BNC7-P-C-XX-ST-CA3-MKT.SLDDRW

<p>UNLESS OTHERWISE SPECIFIED, DIMENSIONS ARE IN MILLIMETERS [INCHES]. TOLERANCES ARE:</p> <p>DECIMALS ANGLES</p> <p>.X: ± 0.3 [.01] 2°</p> <p>.XX: ± 0.13 [.005]</p> <p>.XXX: ± 0.051 [.0020]</p>	<p>PROPRIETARY NOTE</p> <p>THIS DOCUMENT CONTAINS INFORMATION CONFIDENTIAL AND PROPRIETARY TO SAMTEC, INC. AND SHALL NOT BE REPRODUCED OR TRANSFERRED TO OTHER DOCUMENTS OR DISCLOSED TO OTHERS OR USED FOR ANY PURPOSE OTHER THAN THAT WHICH IT WAS OBTAINED WITHOUT THE EXPRESSED WRITTEN CONSENT OF SAMTEC, INC.</p>	 <p>520 PARK EAST BLVD, NEW ALBANY, IN 47150 PHONE: 812-944-6733 FAX: 812-948-5047 e-Mail: info@SAMTEC.com code: 55322</p>
<p>MATERIAL: DO NOT SCALE DRAWING SHEET SCALE: 2:1</p>	<p>DESCRIPTION: BNC STR, PLUG RG179-75 OHM</p>	
<p>DWG. NO. BNC7-P-C-XX-ST-CA3</p>		
<p>BY: G.HERMAN 06/19/2008</p>	<p>SHEET 1 OF 3</p>	

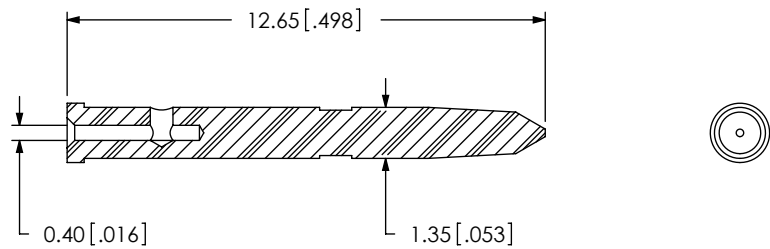

SCALE: 4:1

SAMTEC PART NUMBER	ITEM
BNC7-PIN-002-X	PIN

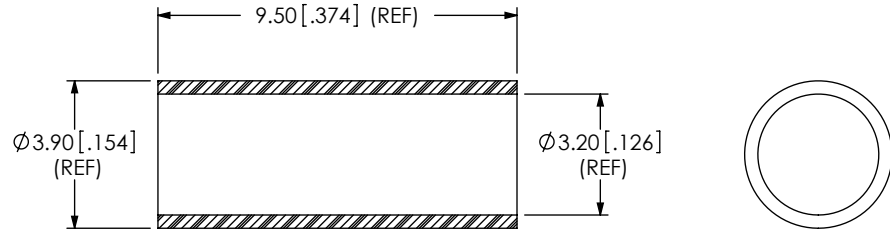

SCALE: 4:1

SAMTEC PART NUMBER	ITEM
SMA-FER-001-X	OUTER FERRULE

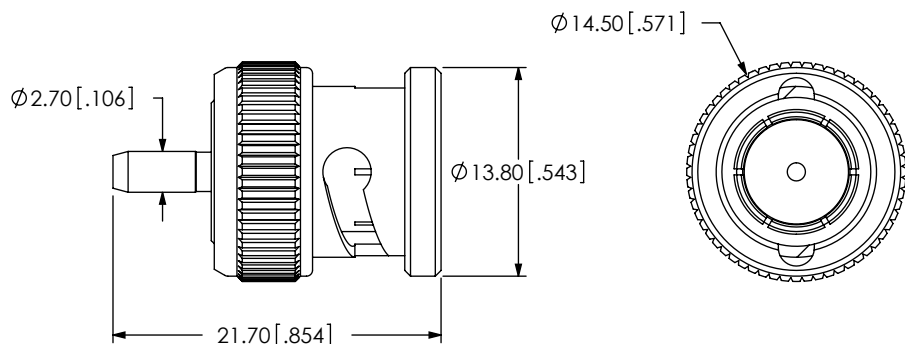

SAMTEC PART NUMBER	ITEM
SUB-BNC7-P-C-XX-ST-CA3	SUB ASSEMBLY

F:\DWG\MISC\MKTG\BNC7-P-C-XX-ST-CA3-MKT.SLDRW

PROPRIETARY NOTE

THIS DOCUMENT CONTAINS INFORMATION CONFIDENTIAL AND PROPRIETARY TO SAMTEC, INC. AND SHALL NOT BE REPRODUCED OR TRANSFERRED TO OTHER DOCUMENTS OR DISCLOSED TO OTHERS OR USED FOR ANY PURPOSE OTHER THAN THAT WHICH IT WAS OBTAINED WITHOUT THE EXPRESSED WRITTEN CONSENT OF SAMTEC, INC.

DO NOT SCALE DRAWING

SHEET SCALE: 2:1



520 PARK EAST BLVD, NEW ALBANY, IN 47150
 PHONE: 812-944-6733 FAX: 812-948-5047
 e-Mail: info@SAMTEC.com code: 55322

DESCRIPTION: BNC STR, PLUG RG179-75 OHM

DWG. NO. BNC7-P-C-XX-ST-CA3

BY: G.HERMAN 06/19/2008 SHEET 2 OF 3

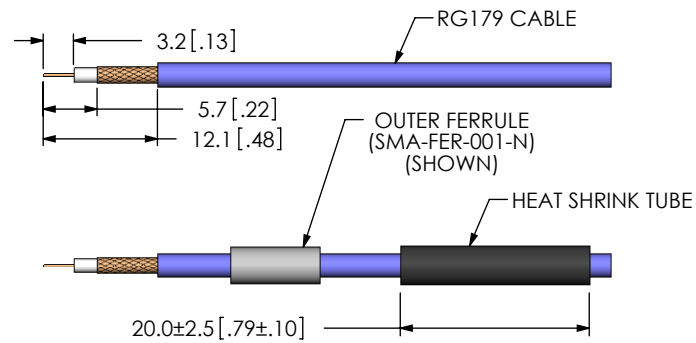

STRIP AND TIN INNER CONDUCTOR

ADD HEAT SHRINK TUBE AND FERRULE

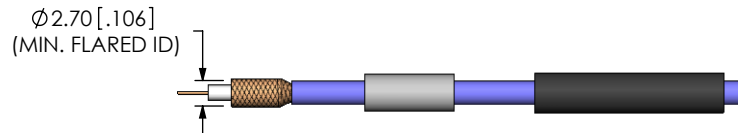

FLARE SHIELD

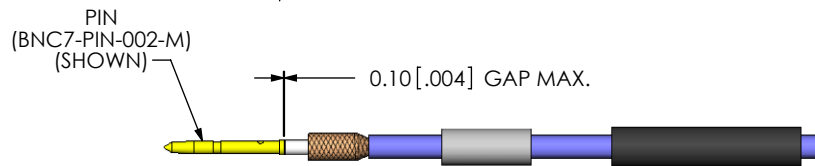

SOLDER SIGNAL PIN

Ⓢ 0.16^{+0.17}_{-0.03} [.006^{+0.007}_{-.001}]
TO CENTER CONTACT

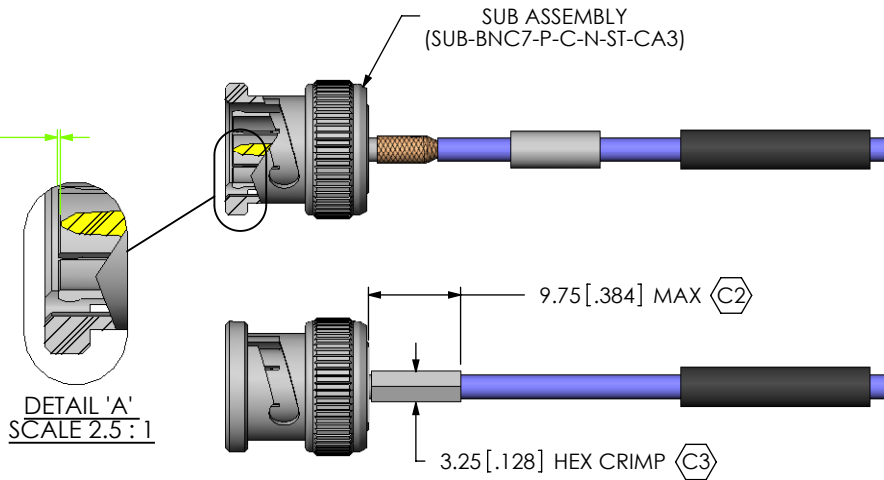

ADD SUB-BNC7-P-C-X-ST-CA3

CRIMP FERRULE
(USE RF CRIMP HAND TOOL #CAT-HT-126667-21)

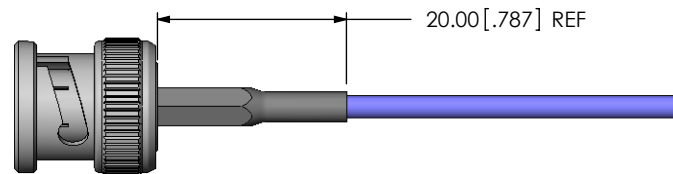

APPLY HEAT SHRINK TUBE

F:\DWG\MISC\MKTG\BNC7-P-C-XX-ST-CA3-MKT.SLDDRW

PROPRIETARY NOTE

THIS DOCUMENT CONTAINS INFORMATION CONFIDENTIAL AND PROPRIETARY TO SAMTEC, INC. AND SHALL NOT BE REPRODUCED OR TRANSFERRED TO OTHER DOCUMENTS OR DISCLOSED TO OTHERS OR USED FOR ANY PURPOSE OTHER THAN THAT WHICH IT WAS OBTAINED WITHOUT THE EXPRESSED WRITTEN CONSENT OF SAMTEC, INC.

DO NOT SCALE DRAWING

SHEET SCALE: 1.25:1



520 PARK EAST BLVD, NEW ALBANY, IN 47150
PHONE: 812-944-6733 FAX: 812-948-5047
e-Mail: info@SAMTEC.com code: 55322

DESCRIPTION:
BNC STR, PLUG RG179-75 OHM

DWG. NO.
BNC7-P-C-XX-ST-CA3

BY: G.HERMAN 06/19/2008 SHEET 3 OF 3