

LCD BACK-LIGHT TERMINAL

Straight type

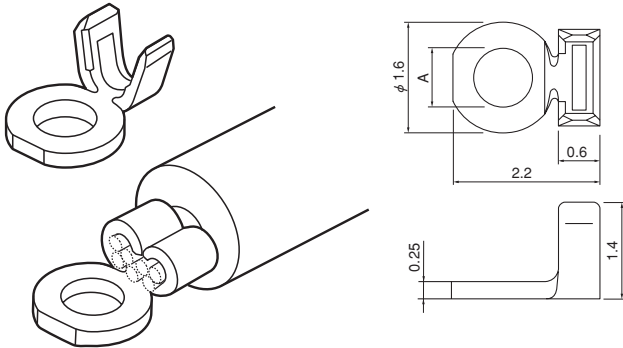

Bent type

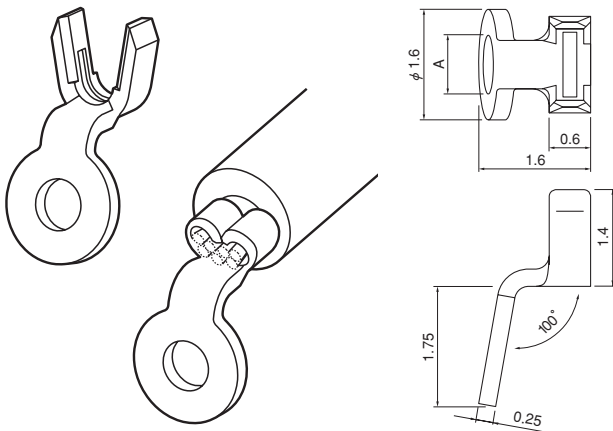

- Provides soldering connection between the Dumet wire and lead wire of the LCD Back-light CCFT.
- Improves quality and shortens lead-time by crimping both ends and there is no need for the rounding process of the lead wire.
- Also applicable to other connections between the pin and lead wire of the Solenoid or Coil inside small equipment such as Digital Cameras.
- Post plating feature provides tin/lead plating inside the ring and ensures reliable solder ability.
- Five types are available for different sizes of Dumet wire.

	Straight type	Dimension A	Bent type	Dimension A
Model No.	SRI-00T-0.5	φ 0.5	SRI-00T-0.5L	φ 0.5
	SRI-00T-0.6	φ 0.6	SRI-00T-0.6L	φ 0.6
	SRI-00T-0.7	φ 0.7	SRI-00T-0.7L	φ 0.7
	SRI-00T-0.9	φ 0.85	SRI-00T-0.9L	φ 0.85
	SRI-00T-1.0	φ 0.95	SRI-00T-1.0L	φ 0.95
Material and Finish	Copper alloy, nickel-undercoated, tin/copper alloy-plated			
Q'ty / reel	30,000		16,000	
Applicable wire	AWG#28~#24 (0.08mm ² ~0.22mm ²)			
Crimping tool	Crimping machine/ AP-K2N Applicator/ MKS-L Dies/ SRI-00 (Straight type), SRI-00-L (Bent type) Crimp applicator with dies/ APLMK SRI-00, APLMK SRI-00-L			

RoHS compliance This product displays (LF) on a label.

* Compliant with RoHS.

* Refer to "General Instruction and Notice when using Terminals and Connectors" at the end of this catalog.

* Contact JST for details.