

## 16/8-BIT SINGLE-CHIP MICROCONTROLLER

The  $\mu$ PD784038 is a product of the  $\mu$ PD784038 sub-series in the 78K/IV series. It contains various peripheral hardware such as ROM, RAM, I/O ports, 8-bit resolution A/D and D/A converters, timers, serial interface, and interrupt functions, as well as a high-speed, high-performance CPU.

In addition, the  $\mu$ PD78P4038 (one-time PROM or EPROM product), which can be operated within the same power supply voltage ranges as masked-ROM products, and development tools are supported.

**For specific functions and other detailed information, consult the following user's manual.**

**This manual is required reading for design work.**

$\mu$ PD784038, 784038Y Sub-Series User's Manual, Hardware : U11316E  
78K/IV Series User's Manual, Instruction : U10905E

## FEATURES

- Pin-compatible with the  $\mu$ PD78234,  $\mu$ PD784026, and  $\mu$ PD784038Y sub-series
- Expanded internal memory spaces in the  $\mu$ PD78234 and  $\mu$ PD784026 sub-series
- Minimum instruction execution time: 125 ns (at 32 MHz)
- Number of I/O ports: 64
- Timer/counters: 16-bit timer/counter  $\times$  3 units  
16-bit timer  $\times$  1 unit
- A/D converter: 8-bit resolution  $\times$  8 channels
- D/A converter: 8-bit resolution  $\times$  2 channels
- Serial interface: 3 channels  
UART/IOE (3-wire serial I/O): 2 channels  
CSI (3-wire serial I/O, 2-wire serial I/O): 1 channel
- PWM outputs: 2
- Standby function  
HALT/STOP/IDLE mode
- Clock frequency division function
- Watchdog timer: 1 channel
- Clock output function  
Selectable from  $f_{CLK}$ ,  $f_{CLK}/2$ ,  $f_{CLK}/4$ ,  $f_{CLK}/8$ , or  $f_{CLK}/16$
- Supply voltage:  $V_{DD} = 2.7$  to  $5.5$  V

## APPLICATIONS

LBP, automatic-focusing camera, PPC, printer, electronic typewriter, air conditioner, electronic musical instruments, cellular telephone, etc.

**This manual describes the  $\mu$ PD784038 unless otherwise specified.**

The information in this document is subject to change without notice.

## ORDERING INFORMATION

Part number	Package	Internal ROM (bytes)	Internal RAM (bytes)
$\mu$ PD784035GC-xxx-3B9	80-pin plastic QFP (14 × 14 × 2.7 mm)	48K	2,048
$\mu$ PD784035GC-xxx-8BT	80-pin plastic QFP (14 × 14 × 1.4 mm)	48K	2,048
$\mu$ PD784035GK-xxx-BE9	80-pin plastic TQFP (fine pitch) (12 × 12 mm)	48K	2,048
$\mu$ PD784036GC-xxx-3B9	80-pin plastic QFP (14 × 14 × 2.7 mm)	64K	2,048
$\mu$ PD784036GC-xxx-8BT	80-pin plastic QFP (14 × 14 × 1.4 mm)	64K	2,048
$\mu$ PD784036GK-xxx-BE9	80-pin plastic TQFP (fine pitch) (12 × 12 mm)	64K	2,048
★ $\mu$ PD784037GC-xxx-3B9	80-pin plastic QFP (14 × 14 × 2.7 mm)	96K	3,584
★ $\mu$ PD784037GC-xxx-8BT	80-pin plastic QFP (14 × 14 × 1.4 mm)	96K	3,584
★ $\mu$ PD784037GK-xxx-BE9	80-pin plastic TQFP (fine pitch) (12 × 12 mm)	96K	3,584
★ $\mu$ PD784038GC-xxx-3B9	80-pin plastic QFP (14 × 14 × 2.7 mm)	128K	4,352
★ $\mu$ PD784038GC-xxx-8BT	80-pin plastic QFP (14 × 14 × 1.4 mm)	128K	4,352
★ $\mu$ PD784038GK-xxx-BE9	80-pin plastic TQFP (fine pitch) (12 × 12 mm)	128K	4,352

**Remark** xxx is ROM code suffix.

★ 78K/IV SERIES PRODUCT DEVELOPMENT DIAGRAM

: Under mass production

: Under development

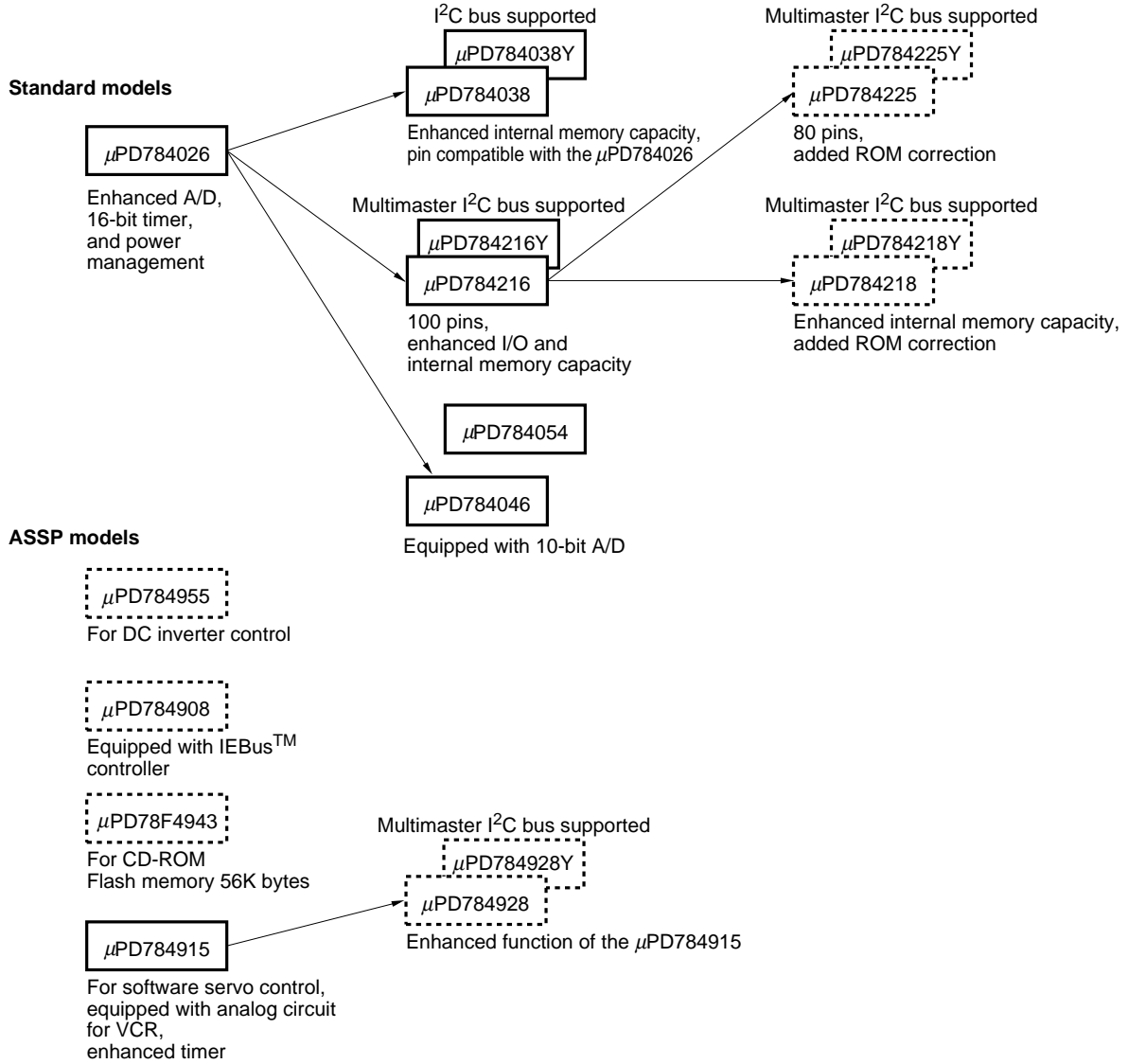

FUNCTIONS

Product		μPD784035	μPD784036	μPD784037	μPD784038
Item					
Number of basic instructions (mnemonics)		113			
General-purpose register		8 bits × 16 registers × 8 banks, or 16 bits × 8 registers × 8 banks (memory mapping)			
Minimum instruction execution time		125 ns/250 ns/500 ns/1,000 ns (at 32 MHz)			
Internal memory	ROM	48K bytes	64K bytes	96K bytes	128K bytes
	RAM	2,048 bytes		3,584 bytes	4,352 bytes
Memory space		Program and data: 1M byte			
I/O ports	Total	64			
	Input	8			
	Input/output	56			
Additional function pins <sup>Note</sup>	Pins with pull-up resistor	54			
	LED direct drive outputs	24			
	Transistor direct drive	8			
Real-time output ports		4 bits × 2, or 8 bits × 1			
Timer/counter		Timer/counter 0: (16 bits)	Timer register × 1 Capture register × 1 Compare register × 2	Pulse output capability • Toggle output • PWM/PPG output • One-shot pulse output	
		Timer/counter 1: (8/16 bits)	Timer register × 1 Capture register × 1 Capture/compare register × 1 Compare register × 1	Pulse output capability • Real-time output (4 bits × 2)	
		Timer/counter 2: (8/16 bits)	Timer register × 1 Capture register × 1 Capture/compare register × 1 Compare register × 1	Pulse output capability • Toggle output • PWM/PPG output	
		Timer 3 (8/16 bits)	Timer register × 1 Compare register × 1		
PWM outputs		12-bit resolution × 2 channels			
Serial interface		UART/IOE (3-wire serial I/O) : 2 channels (incorporating baud rate generator) CSI (3-wire serial I/O, 2-wire serial I/O): 1 channel			
A/D converter		8-bit resolution × 8 channels			
D/A converter		8-bit resolution × 2 channels			
Clock output		Selected from f <sub>CLK</sub> , f <sub>CLK</sub> /2, f <sub>CLK</sub> /4, f <sub>CLK</sub> /8, or f <sub>CLK</sub> /16 (can be used as a 1-bit output port)			
Watchdog timer		1 channel			
Standby		HALT/STOP/IDLE mode			
Interrupt	Hardware source	23 (16 internal, 7 external (sampling clock variable input: 1))			
	Software source	BRK instruction, BRKCS instruction, operand error			
	Nonmaskable	1 internal, 1 external			
	Maskable	15 internal, 6 external			
		<ul style="list-style-type: none"> <li>• 4-level programmable priority</li> <li>• 3 operation statuses: vectored interrupt, macro service, context switching</li> </ul>			
Supply voltage		V <sub>DD</sub> = 2.7 to 5.5 V			
Package		80-pin plastic QFP (14 × 14 × 2.7 mm) 80-pin plastic QFP (14 × 14 × 1.4 mm) 80-pin plastic TQFP (fine pitch) (12 × 12 mm)			

**Note** Additional function pins are included in the I/O pins.

**CONTENTS**

<b>1.</b>	<b>DIFFERENCES BETWEEN μPD784038 SUB-SERIES .....</b>	<b>7</b>
<b>2.</b>	<b>MAIN DIFFERENCES BETWEEN μPD784038, μPD784038Y, μPD784026, AND μPD78234 SUB-SERIES .....</b>	<b>8</b>
<b>3.</b>	<b>PIN CONFIGURATION (TOP VIEW) .....</b>	<b>9</b>
<b>4.</b>	<b>SYSTEM CONFIGURATION EXAMPLE (PPC).....</b>	<b>11</b>
<b>5.</b>	<b>BLOCK DIAGRAM .....</b>	<b>12</b>
<b>6.</b>	<b>PIN FUNCTIONS .....</b>	<b>13</b>
6.1	Port Pins .....	13
6.2	Non-Port Pins .....	15
6.3	I/O Circuits for Pins and Handling of Unused Pins .....	17
<b>7.</b>	<b>CPU ARCHITECTURE .....</b>	<b>20</b>
7.1	Memory Space .....	20
7.2	CPU Registers .....	25
7.2.1	General-purpose registers .....	25
7.2.2	Control registers .....	26
7.2.3	Special function registers (SFRs) .....	27
<b>8.</b>	<b>PERIPHERAL HARDWARE FUNCTIONS .....</b>	<b>32</b>
8.1	Ports .....	32
8.2	Clock Generator .....	33
8.3	Real-Time Output Port .....	35
8.4	Timers/Counters .....	36
8.5	PWM Output (PWM0, PWM1) .....	38
8.6	A/D Converter .....	39
8.7	D/A Converter .....	40
8.8	Serial Interface .....	41
8.8.1	Asynchronous serial interface/three-wire serial I/O (UART/IOE).....	42
8.8.2	Synchronous serial interface (CSI) .....	44
8.9	Clock Output Function .....	45
8.10	Edge Detection Function .....	46
8.11	Watchdog Timer .....	46
<b>9.</b>	<b>INTERRUPT FUNCTION .....</b>	<b>47</b>
9.1	Interrupt Source .....	47
9.2	Vectored Interrupt.....	49
9.3	Context Switching .....	50
9.4	Macro Service.....	50
9.5	Examples of Macro Service Applications .....	51

<b>10. LOCAL BUS INTERFACE .....</b>	<b>53</b>
<b>10.1 Memory Expansion .....</b>	<b>53</b>
<b>10.2 Memory Space .....</b>	<b>54</b>
<b>10.3 Programmable Wait .....</b>	<b>55</b>
<b>10.4 Pseudo-Static RAM Refresh Function .....</b>	<b>55</b>
<b>10.5 Bus Hold Function .....</b>	<b>55</b>
<b>11. STANDBY FUNCTION .....</b>	<b>56</b>
<b>12. RESET FUNCTION .....</b>	<b>57</b>
<b>13. INSTRUCTION SET .....</b>	<b>58</b>
<b>14. ELECTRICAL CHARACTERISTICS .....</b>	<b>63</b>
<b>15. PACKAGE DRAWINGS .....</b>	<b>84</b>
<b>16. RECOMMENDED SOLDERING CONDITIONS .....</b>	<b>87</b>
<b>APPENDIX A DEVELOPMENT TOOLS .....</b>	<b>89</b>
<b>APPENDIX B RELATED DOCUMENTS .....</b>	<b>92</b>

**1. DIFFERENCES BETWEEN μPD784038 SUB-SERIES**

The only difference between the μPD784035, μPD784036, μPD784037, and μPD784038 is their capacity of internal memory.

The μPD78P4038 is produced by replacing the masked ROM in the μPD784035, μPD784036, μPD784037, or μPD784038 with 128K-byte one-time PROM or EPROM. Table 1-1 shows the differences between these products.

**Table 1-1. Differences between the μPD784038 Sub-Series**

Product Item	μPD784031	μPD784035	μPD784036	μPD784037	μPD784038	μPD78P4038
Internal ROM	Unavailable	48K bytes (masked ROM)	64K bytes (masked ROM)	96K bytes (masked ROM)	128K bytes (masked ROM)	128K bytes (one-time PROM or EPROM)
Internal RAM	2,048 bytes			3,584 bytes	4,352 bytes	
Package	80-pin plastic QFP (14 × 14 × 2.7 mm) 80-pin plastic QFP (14 × 14 × 1.4 mm) 80-pin plastic TQFP (fine pitch) (12 × 12 mm)					80-pin ceramic WQFN (14 × 14mm)

2. MAIN DIFFERENCES BETWEEN μPD784038, μPD784038Y, μPD784026, AND μPD78234 SUB-SERIES

Series		μPD784038 sub-series μPD784038Y sub-series	μPD784026 sub-series	μPD78234 sub-series
Item				
Number of basic instructions (mnemonics)		113		65
Minimum instruction execution time		125 ns (at 32 MHz)	160 ns (at 25 MHz)	333 ns (at 12 MHz)
Memory space (program/data)		1M byte in total		64K bytes/1M byte
Timer/counter		16-bit timer/counter × 1 8/16-bit timer/counter × 2 8/16-bit timer × 1		16-bit timer/counter × 1 8-bit timer/counter × 2 8-bit timer × 1
Clock output function		Available		Unavailable
Watchdog timer		Available		Unavailable
Serial interface		UART/IOE (3-wire serial I/O) × 2 channels CSI (3-wire serial I/O, 2-wire serial I/O, I <sup>2</sup> C bus <sup>Note</sup> ) × 1 channel	UART/IOE (3-wire serial I/O) × 2 channels CSI (3-wire serial I/O, SBI) × 1 channel	UART × 1 channel CSI (3-wire serial I/O, SBI) × 1 channel
Interrupt	Context switching	Available		Unavailable
	Priority	4 levels		2 levels
Standby function		3 modes (HALT, STOP, IDLE)		2 modes (HALT, STOP)
Operation clock switching		Selectable from f <sub>xx</sub> /2, f <sub>xx</sub> /4, f <sub>xx</sub> /8, or f <sub>xx</sub> /16		Fixed to f <sub>xx</sub> /2
Pin functions	MODE pin	Unavailable		To specify ROM-less mode (always in the high level for the μPD78233 or μPD78237)
	TEST pin	Pin for testing the device Low level during ordinary use		Unavailable
Package		80-pin plastic QFP (14 × 14 × 2.7 mm) 80-pin plastic QFP (14 × 14 × 1.4 mm) 80-pin plastic TQFP (fine pitch) (12 × 12 mm) 80-pin ceramic WQFN (14 × 14 mm): for the μPD78P4038 and μPD78P4038Y only	80-pin plastic QFP (14 × 14 × 2.7 mm) 80-pin plastic TQFP (fine pitch) (12 × 12 mm): for the μPD784021 only 80-pin ceramic WQFN (14 × 14 mm): for the μPD78P4026 only	80-pin plastic QFP (14 × 14 × 2.7 mm) 94-pin plastic QFP (20 × 20 mm) 84-pin plastic QFJ (1,150 × 1,150 mil) 94-pin ceramic WQFN (20 × 20 mm): for the μPD78P238 only

**Note** For the μPD784038Y sub-series only.



3. PIN CONFIGURATION (TOP VIEW)

- **80-pin plastic QFP (14 × 14 × 2.7 mm)**  
 μPD784035GC-xxx-3B9, μPD784036GC-xxx-3B9, μPD784037GC-xxx-3B9, μPD784038GC-xxx-3B9
- **80-pin plastic QFP (14 × 14 × 1.4 mm)**  
 μPD784035GC-xxx-8BT, μPD784036GC-xxx-8BT, μPD784037GC-xxx-8BT, μPD784038GC-xxx-8BT
- **80-pin plastic TQFP (fine pitch) (12 × 12 mm)**  
 μPD784035GK-xxx-BE9, μPD784036GK-xxx-BE9, μPD784037GK-xxx-BE9, μPD784038GK-xxx-BE9

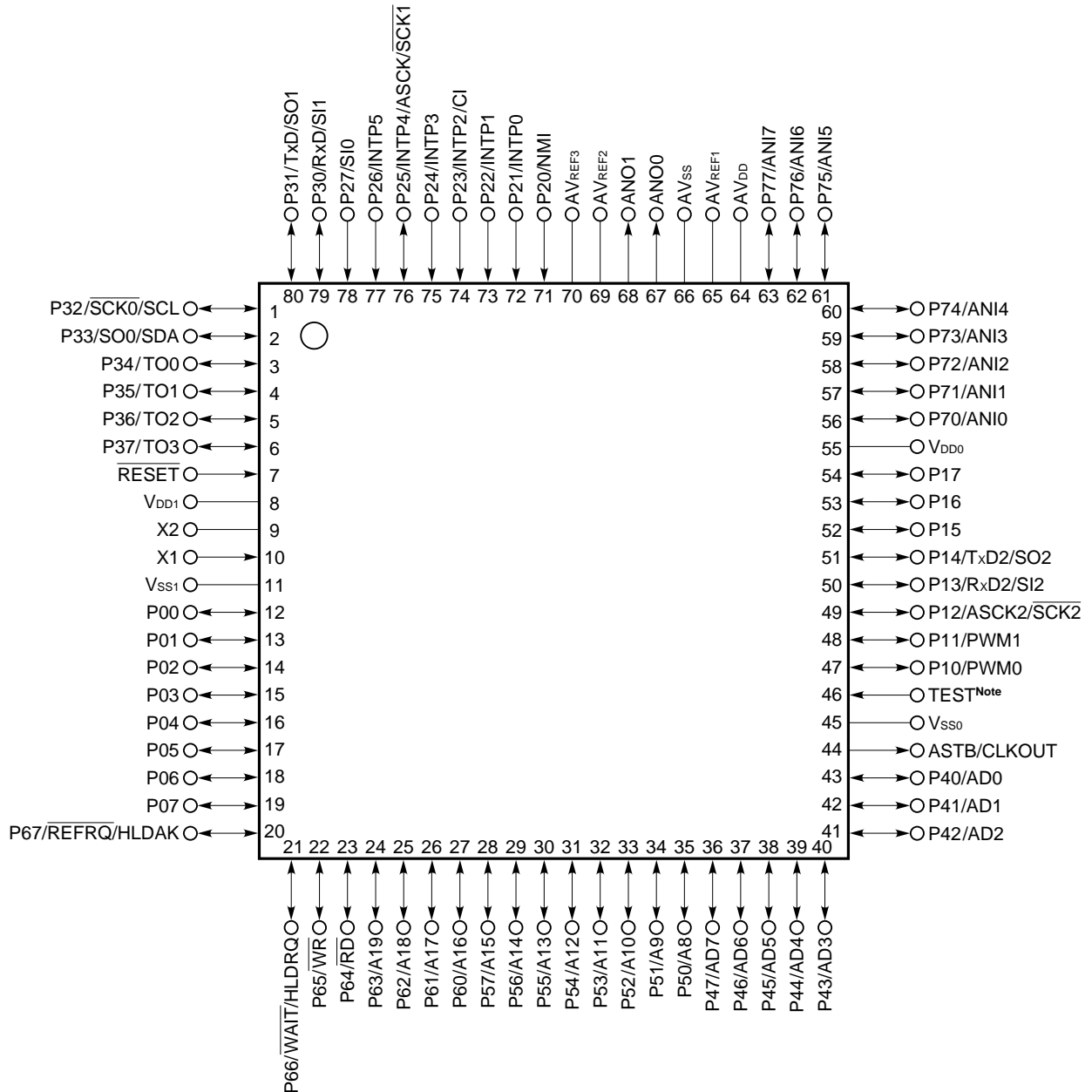

**Note** Connect the TEST pin to the VSS0 pin directly.

A8-A19	: Address bus	P60-P67	: Port 6
AD0-AD7	: Address/data bus	P70-P77	: Port 7
ANI0-ANI7	: Analog input	PWM0, PWM1	: Pulse width modulation output
ANO0, ANO1	: Analog output	$\overline{RD}$	: Read strobe
ASCK, ASCK2	: Asynchronous serial clock	$\overline{REFRQ}$	: Refresh request
ASTB	: Address strobe	$\overline{RESET}$	: Reset
AV <sub>DD</sub>	: Analog power supply	RxD, RxD2	: Receive data
AV <sub>REF1</sub> -AV <sub>REF3</sub>	: Reference voltage	$\overline{SCK0}$ - $\overline{SCK2}$	: Serial clock
AV <sub>SS</sub>	: Analog ground	SCL	: Serial clock
CI	: Clock input	SDA	: Serial data
CLKOUT	: Clock output	SI0-SI2	: Serial input
HLD <sub>AK</sub>	: Hold acknowledge	SO0-SO2	: Serial output
HLD <sub>RQ</sub>	: Hold request	TEST	: Test
INTP0-INTP5	: Interrupt from peripherals	TO0-TO3	: Timer output
NMI	: Non-maskable interrupt	TxD, TxD2	: Transmit data
P00-P07	: Port 0	V <sub>DD0</sub> , V <sub>DD1</sub>	: Power supply
P10-P17	: Port 1	V <sub>SS0</sub> , V <sub>SS1</sub>	: Ground
P20-P27	: Port 2	$\overline{WAIT}$	: Wait
P30-P37	: Port 3	$\overline{WR}$	: Write strobe
P40-P47	: Port 4	X1, X2	: Crystal
P50-P57	: Port 5		

4. SYSTEM CONFIGURATION EXAMPLE (PPC)

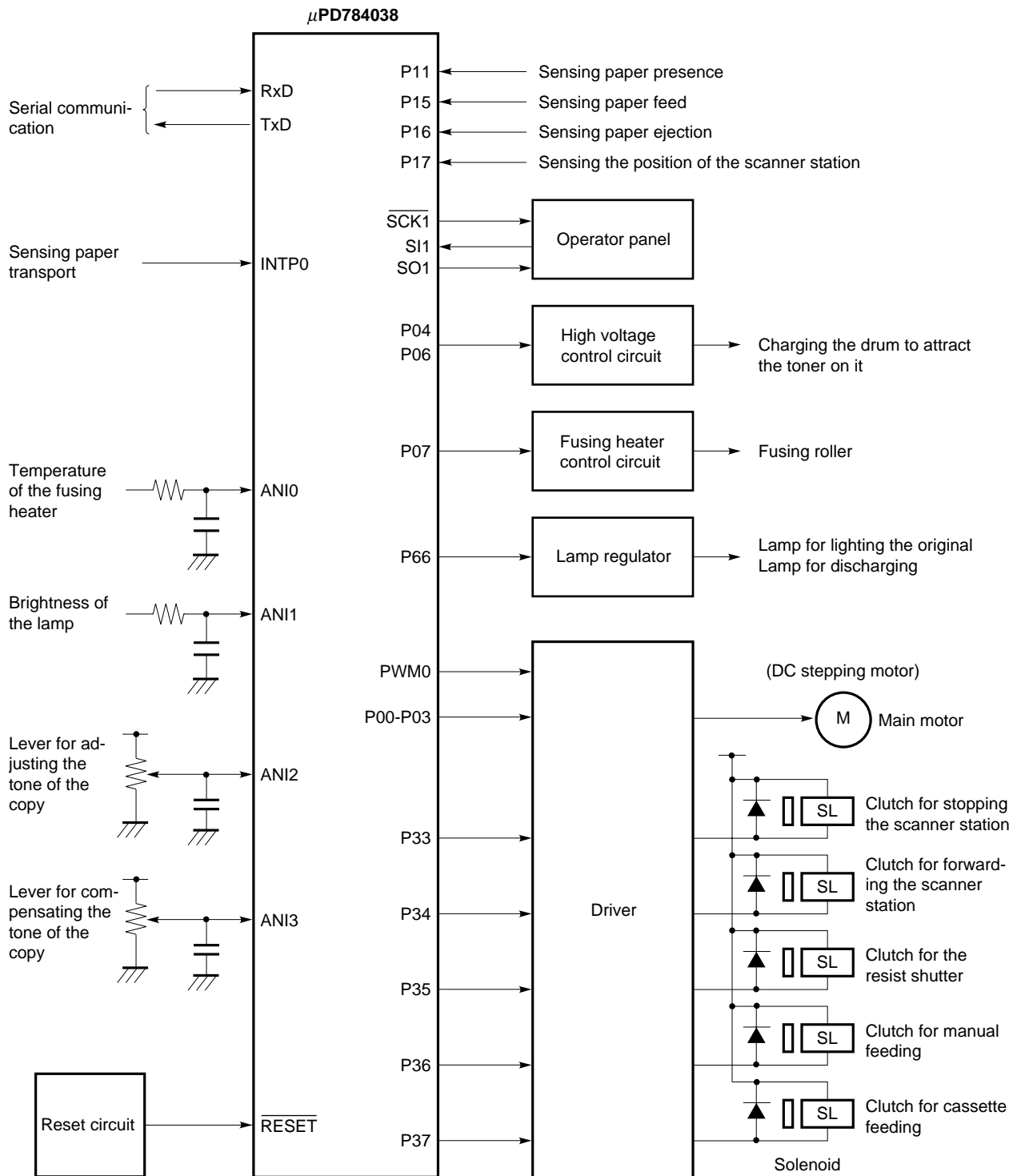

5. BLOCK DIAGRAM

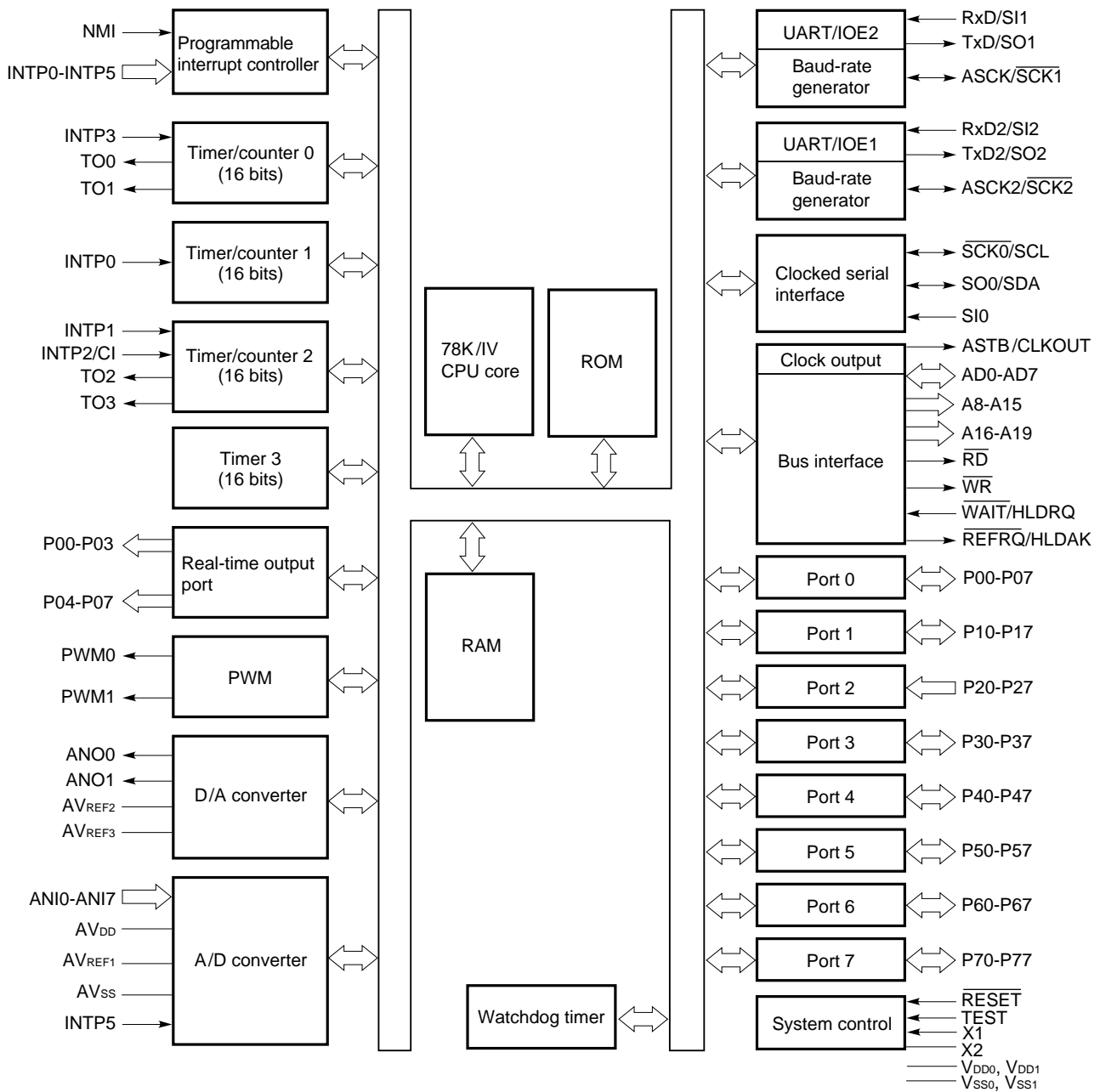

**Remark** The internal ROM or RAM capacity differs for each product.

6. PIN FUNCTIONS

6.1 Port Pins (1/2)

Pin	I/O	Dual-function	Function
P00-P07	I/O	-	<p>Port 0 (P0):</p> <ul style="list-style-type: none"> <li>• 8-bit I/O port.</li> <li>• Functions as a real-time output port (4 bits × 2).</li> <li>• Inputs and outputs can be specified bit by bit.</li> <li>• The use of the pull-up resistors can be specified by software for the pins in the input mode together.</li> <li>• Can drive a transistor.</li> </ul>
P10	I/O	PWM0	<p>Port 1 (P1):</p> <ul style="list-style-type: none"> <li>• 8-bit I/O port.</li> <li>• Inputs and outputs can be specified bit by bit.</li> <li>• The use of the pull-up resistors can be specified by software for the pins in the input mode together.</li> <li>• Can drive LED.</li> </ul>
P11		PWM1	
P12		ASCK2/ $\overline{\text{SCK2}}$	
P13		RxD2/SI2	
P14		TxD2/SO2	
P15-P17		-	
P20	Input	NMI	<p>Port 2 (P2):</p> <ul style="list-style-type: none"> <li>• 8-bit input-only port.</li> <li>• P20 does not function as a general-purpose port (nonmaskable interrupt). However, the input level can be checked by an interrupt service routine.</li> <li>• The use of the pull-up resistors can be specified by software for pins P22 to P27 (in units of 6 bits).</li> <li>• The P25/INTP4/ASCK/<math>\overline{\text{SCK1}}</math> pin functions as the <math>\overline{\text{SCK1}}</math> output pin by CSIM1.</li> </ul>
P21		INTP0	
P22		INTP1	
P23		INTP2/CI	
P24		INTP3	
P25		INTP4/ASCK/ $\overline{\text{SCK1}}$	
P26		INTP5	
P27		SI0	
P30	I/O	RxD/SI1	<p>Port 3 (P3):</p> <ul style="list-style-type: none"> <li>• 8-bit I/O port.</li> <li>• Inputs and outputs can be specified bit by bit.</li> <li>• The use of the pull-up resistors can be specified by software for the pins in the input mode together.</li> </ul>
P31		TxD/SO1	
P32		$\overline{\text{SCK0/SCL}}$	
P33		SO0/SDA	
P34-P37		TO0-TO3	
P40-P47	I/O	AD0-AD7	<p>Port 4 (P4):</p> <ul style="list-style-type: none"> <li>• 8-bit I/O port.</li> <li>• Inputs and outputs can be specified bit by bit.</li> <li>• The use of the pull-up resistors can be specified by software for the pins in the input mode together.</li> <li>• Can drive LED.</li> </ul>
P50-P57	I/O	A8-A15	<p>Port 5 (P5):</p> <ul style="list-style-type: none"> <li>• 8-bit I/O port.</li> <li>• Inputs and outputs can be specified bit by bit.</li> <li>• The use of the pull-up resistors can be specified by software for the pins in the input mode together.</li> <li>• Can drive LED.</li> </ul>

6.1 Port Pins (2/2)

Pin	I/O	Dual-function	Function
P60-P63	I/O	A16-A19	Port 6 (P6): <ul style="list-style-type: none"> <li>• 8-bit I/O port.</li> <li>• Inputs and outputs can be specified bit by bit.</li> <li>• The use of the pull-up resistors can be specified by software for the pins in the input mode together.</li> </ul>
P64		$\overline{RD}$	
P65		$\overline{WR}$	
P66		$\overline{WAIT}/HLDRQ$	
P67		$\overline{REFRQ}/HLDAK$	
P70-P77	I/O	ANI0-ANI7	Port 7 (P7): <ul style="list-style-type: none"> <li>• 8-bit I/O port.</li> <li>• Inputs and outputs can be specified bit by bit.</li> </ul>

6.2 Non-Port Pins (1/2)

Pin	I/O	Dual-function	Function
TO0-TO3	Output	P34-P37	Timer output
CI	Input	P23/INTP2	Input of a count clock for timer/counter 2
RxD	Input	P30/SI1	Serial data input (UART0)
RxD2		P13/SI2	Serial data input (UART2)
TxD	Output	P31/SO1	Serial data output (UART0)
TxD2		P14/SO2	Serial data output (UART2)
ASCK	Input	P25/INTP4/SCK1	Baud rate clock input (UART0)
ASCK2		P12/SCK2	Baud rate clock input (UART2)
SDA	I/O	P33/SO0	Serial data I/O (2-wire serial I/O)
SI0	Input	P27	Serial data input (3-wire serial I/O0)
SI1		P30/RxD	Serial data input (3-wire serial I/O1)
SI2		P13/RxD2	Serial data input (3-wire serial I/O2)
SO0	Output	P33/SDA	Serial data output (3-wire serial I/O0)
SO1		P31/TxD	Serial data output (3-wire serial I/O1)
SO2		P14/TxD2	Serial data output (3-wire serial I/O2)
SCK0	I/O	P32/SCL	Serial clock I/O (3-wire serial I/O0)
SCK1		P25/INTP4/ASCK	Serial clock I/O (3-wire serial I/O1)
SCK2		P12/ASCK2	Serial clock I/O (3-wire serial I/O2)
SCL		P32/SCK0	Serial clock I/O (2-wire serial I/O)
NMI	Input	P20	External interrupt request
INTP0		P21	<ul style="list-style-type: none"> <li>Input of a count clock for timer/counter 1</li> <li>Capture/trigger signal for CR11 or CR12</li> </ul>
INTP1		P22	<ul style="list-style-type: none"> <li>Input of a count clock for timer/counter 2</li> <li>Capture/trigger signal for CR22</li> </ul>
INTP2		P23/CI	<ul style="list-style-type: none"> <li>Input of a count clock for timer/counter 2</li> <li>Capture/trigger signal for CR21</li> </ul>
INTP3		P24	<ul style="list-style-type: none"> <li>Input of a count clock for timer/counter 0</li> <li>Capture/trigger signal for CR02</li> </ul>
INTP4		P25/ASCK/SCK1	-
INTP5		P26	Input of a conversion start trigger for A/D converter
AD0-AD7	I/O	P40-P47	Time multiplexing address/data bus (for connecting external memory)
A8-A15	Output	P50-P57	High-order address bus (for connecting external memory)
A16-A19	Output	P60-P63	High-order address bus during address expansion (for connecting external memory)
RD	Output	P64	Strobe signal output for reading the contents of external memory
WR	Output	P65	Strobe signal output for writing on external memory
WAIT	Input	P66/HLDRQ	Wait signal insertion
REFRQ	Output	P67/HLDAK	Refresh pulse output to external pseudo static memory
HLDRQ	Input	P66/WAIT	Input of bus hold request
HLDAK	Output	P67/REFRQ	Output of bus hold response
ASTB	Output	CLKOUT	Latch timing output of time multiplexing address (A0-A7) (for connecting external memory)
CLKOUT	Output	ASTB	Clock output

6.2 Non-Port Pins (2/2)

Pin	I/O	Dual-function	Function
RESET	Input	-	Chip reset
X1	Input	-	Crystal input for system clock oscillation (A clock pulse can also be input to the X1 pin.)
X2	-		
ANI0-ANI7	Input	P70-P77	Analog voltage inputs for the A/D converter
ANO0, ANO1	Output	-	Analog voltage inputs for the D/A converter
AV <sub>REF1</sub>	-	-	Application of A/D converter reference voltage
AV <sub>REF2</sub> , AV <sub>REF3</sub>			Application of D/A converter reference voltage
AV <sub>DD</sub>			Positive power supply for the A/D converter
AV <sub>SS</sub>			Ground for the A/D converter
V <sub>DD0</sub> <b>Note 1</b>			Positive power supply of the port part
V <sub>DD1</sub> <b>Note 1</b>			Positive power supply except for the port part
V <sub>SS0</sub> <b>Note 2</b>			Ground of the port part
V <sub>SS1</sub> <b>Note 2</b>			Ground except for the port part
TEST			Directly connect to the V <sub>SS</sub> pin. (The TEST pin is for the IC test.)

**Notes 1.** The potential of the V<sub>DD0</sub> pin must be equal to that of the V<sub>DD1</sub> pin.

**2.** The potential of the V<sub>SS0</sub> pin must be equal to that of the V<sub>SS1</sub> pin.



6.3 I/O Circuits for Pins and Handling of Unused Pins

Table 6-1 describes the types of I/O circuits for pins and the handling of unused pins.

Figure 6-1 shows the configuration of these various types of I/O circuits.

Table 6-1. Types of I/O Circuits for Pins and Handling of Unused Pins (1/2)

Pin	I/O circuit type	I/O	Recommended connection method for unused pins
P00-P07	5-H	I/O	Input state : Connect these pins to the V <sub>DD0</sub> pin. Output state: Leave open.
P10/PWM0			
P11/PWM1			
P12/ASCK2/ $\overline{\text{SCK2}}$	8-C		
P13/RxD2/SI2	5-H		
P14/TxD2/SO2			
P15-P17			
P20/NMI	2	Input	Connect these pins to the V <sub>DD0</sub> or V <sub>SS0</sub> pin.
P21/INTP0			
P22/INTP1	2-C		Connect these pins to the V <sub>DD0</sub> pin.
P23/INTP2/CI			
P24/INTP3			
P25/INTP4/ASCK/ $\overline{\text{SCK1}}$	8-C	I/O	Input state : Connect this pin to the V <sub>DD0</sub> pin. Output state: Leave open.
P26/INTP5	2-C	Input	Connect these pins to the V <sub>DD0</sub> pin.
P27/SI0			
P30/RxD/SI1	5-H	I/O	Input state : Connect these pins to the V <sub>DD0</sub> pin. Output state: Leave open.
P31/TxD/SO1			
P32/ $\overline{\text{SCK0}}$ /SCL	10-B		
P33/SO0/SDA			
P34/TO0-P37/TO3	5-H		
P40/AD0-P47/AD7			
P50/A8-P57/A15			
P60/A16-P63/A19			
P64/ $\overline{\text{RD}}$			
P65/ $\overline{\text{WR}}$			
P66/ $\overline{\text{WAIT}}$ /HLDRQ			
P67/ $\overline{\text{REFRQ}}$ /HLDAK			
P70/ANI0-P77/ANI7			
ANO0, ANO1	12	Output	Leave open.
ASTB/CLKOUT	4-B		

Table 6-1. Types of I/O Circuits for Pins and Handling of Unused Pins (2/2)

Pin	I/O circuit type	I/O	Recommended connection method for unused pins
RESET	2	Input	-
TEST	1-A		Connect this pin to the V <sub>SS0</sub> pin directly.
AV <sub>REF1</sub> -AV <sub>REF3</sub>	-		Connect these pins to the V <sub>SS0</sub> pin.
AV <sub>SS</sub>			
AV <sub>DD</sub>			Connect this pin to the V <sub>DD0</sub> pin.

**Caution** When the I/O mode of an I/O dual-function pin is unpredictable, connect the pin to V<sub>DD0</sub> through a resistor of 10 to 100 kilohms (particularly when the voltage of the reset input pin becomes higher than that of the low-level input at power-on or when I/O is switched by software).

**Remark** Since type numbers are consistent in the 78K series, those numbers are not always serial in each product. (Some circuits are not included.)

Figure 6-1. I/O Circuits for Pins

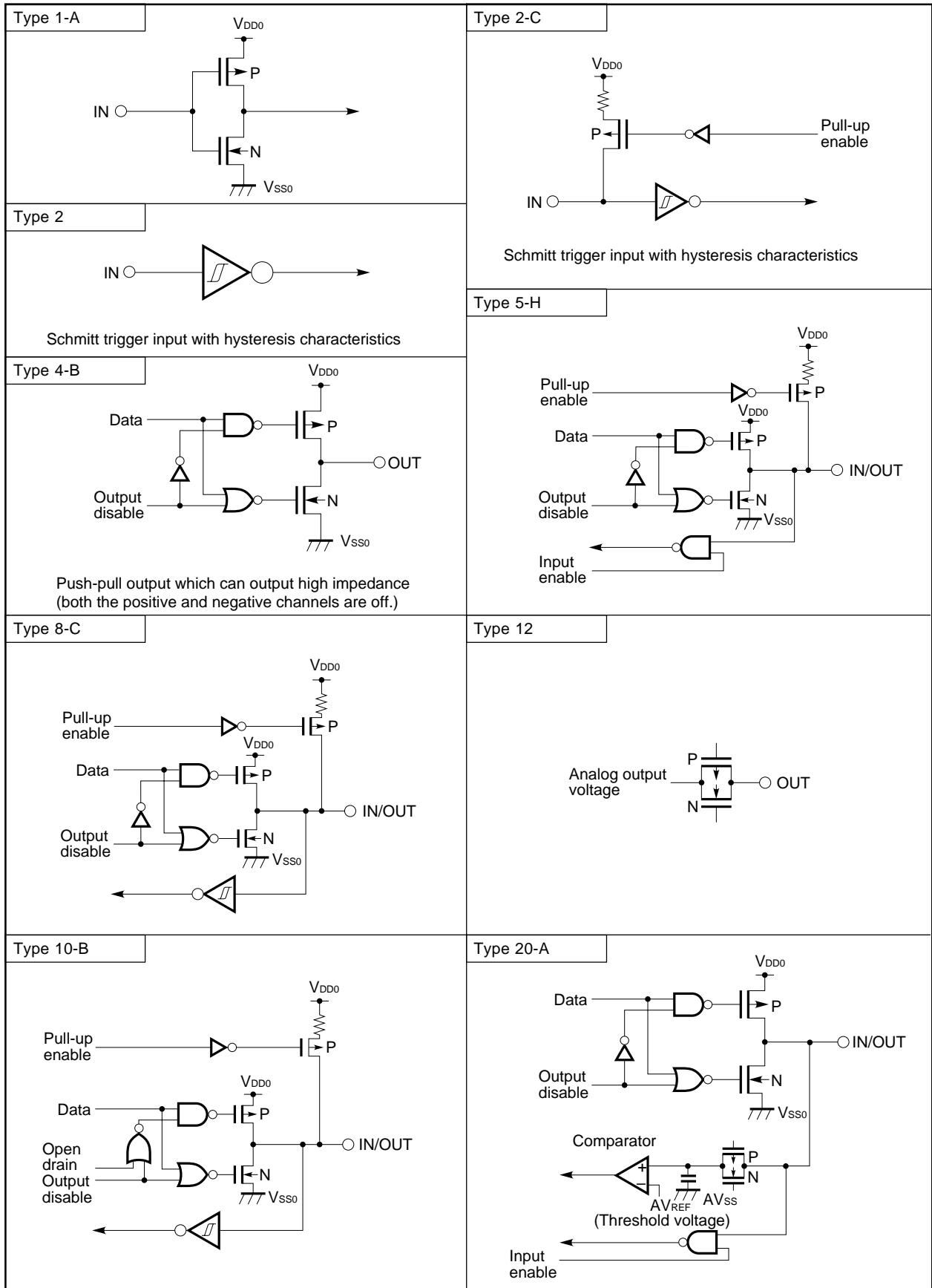

## 7. CPU ARCHITECTURE

### 7.1 Memory Space

A 1M-byte memory space can be accessed. By using a LOCATION instruction, the mode for mapping internal data areas (special function registers and internal RAM) can be selected. A LOCATION instruction must always be executed after a reset, and can be used only once.

#### (1) When the LOCATION 0 instruction is executed

- **Internal memory**

The table below indicates the internal data areas and internal ROM areas of each product.

Product name	Internal data area	Internal ROM area
μPD784035	0F700H-0FFFFH	00000H-0BFFFFH
μPD784036		00000H-0F6FFFH
μPD784037	0F100H-0FFFFH	00000H-0F0FFFH 10000H-17FFFH
μPD784038	0EE00H-0FFFFH	00000H-0FDFFFH 10000H-1FFFFH

**Caution** The following internal ROM areas, existing at the same addresses as the internal data areas, cannot be used when the LOCATION 0 instruction is executed:

Product name	Unusable area
μPD784035	-
μPD784036	0F700H-0FFFFH (2,304 bytes)
μPD784037	0F100H-0FFFFH (3,840 bytes)
μPD784038	0EE00H-0FFFFH (4,608 bytes)

- **External memory**

External memory is accessed in external memory expansion mode.

#### (2) When the LOCATION 0FH instruction is executed

- **Internal memory**

The table below lists the internal data areas and internal ROM areas for each product.

Product name	Internal data area	Internal ROM area
μPD784035	FF700H-FFFFFFH	00000H-0BFFFFH
μPD784036		00000H-0FFFFFFH
μPD784037	0F100H-FFFFFFH	00000H-17FFFH
μPD784038	FEE00H-FFFFFFH	00000H-1FFFFH

- **External memory**

External memory is accessed in external memory expansion mode.

Figure 7-1. μPD784035 Memory Map

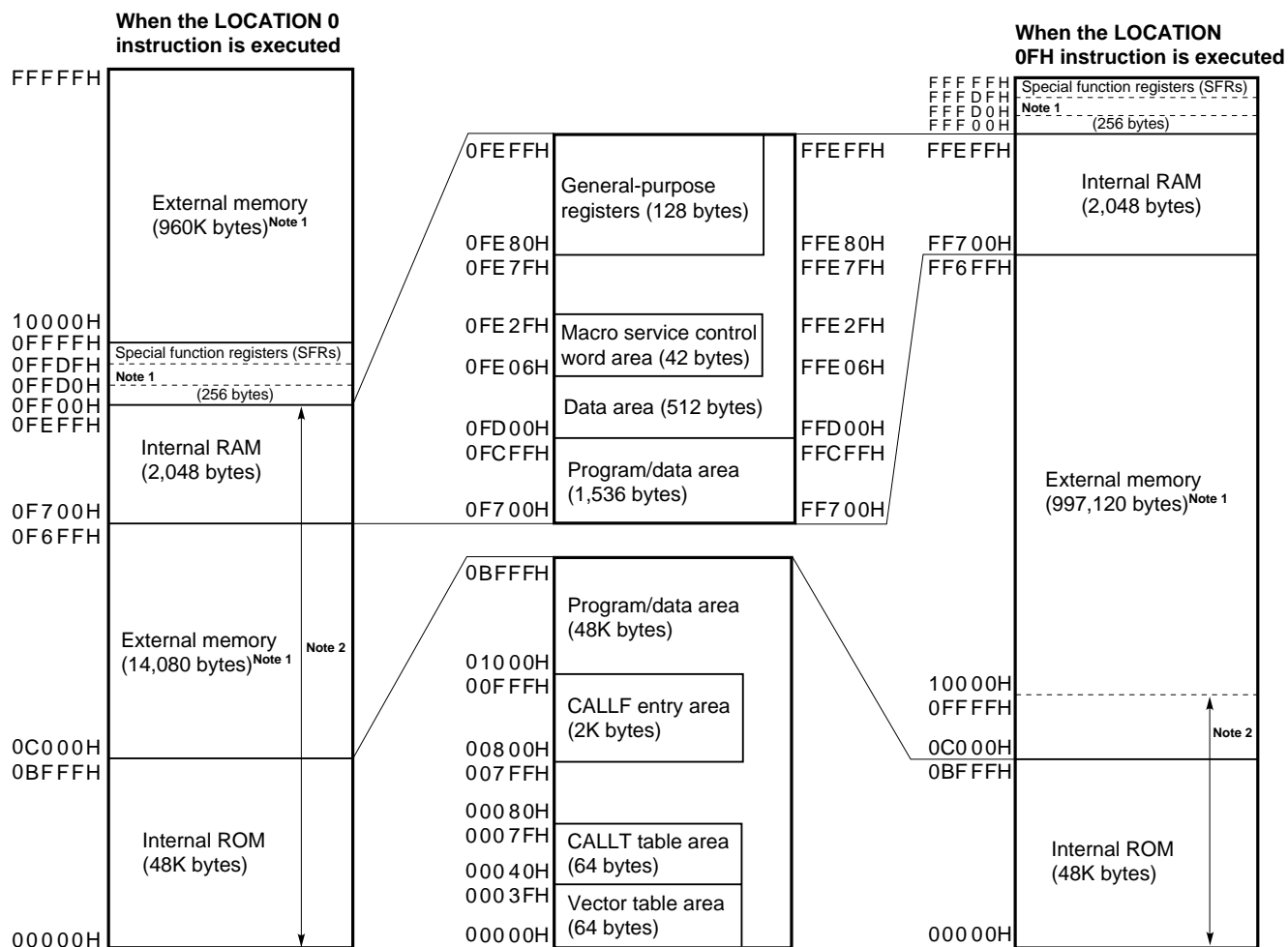

**Notes 1.** Accessed in external memory expansion mode.

**2.** Base area, or entry area based on a reset or interrupt. Internal RAM is excluded in the case of a reset.

Figure 7-2.  $\mu$ PD784036 Memory Map

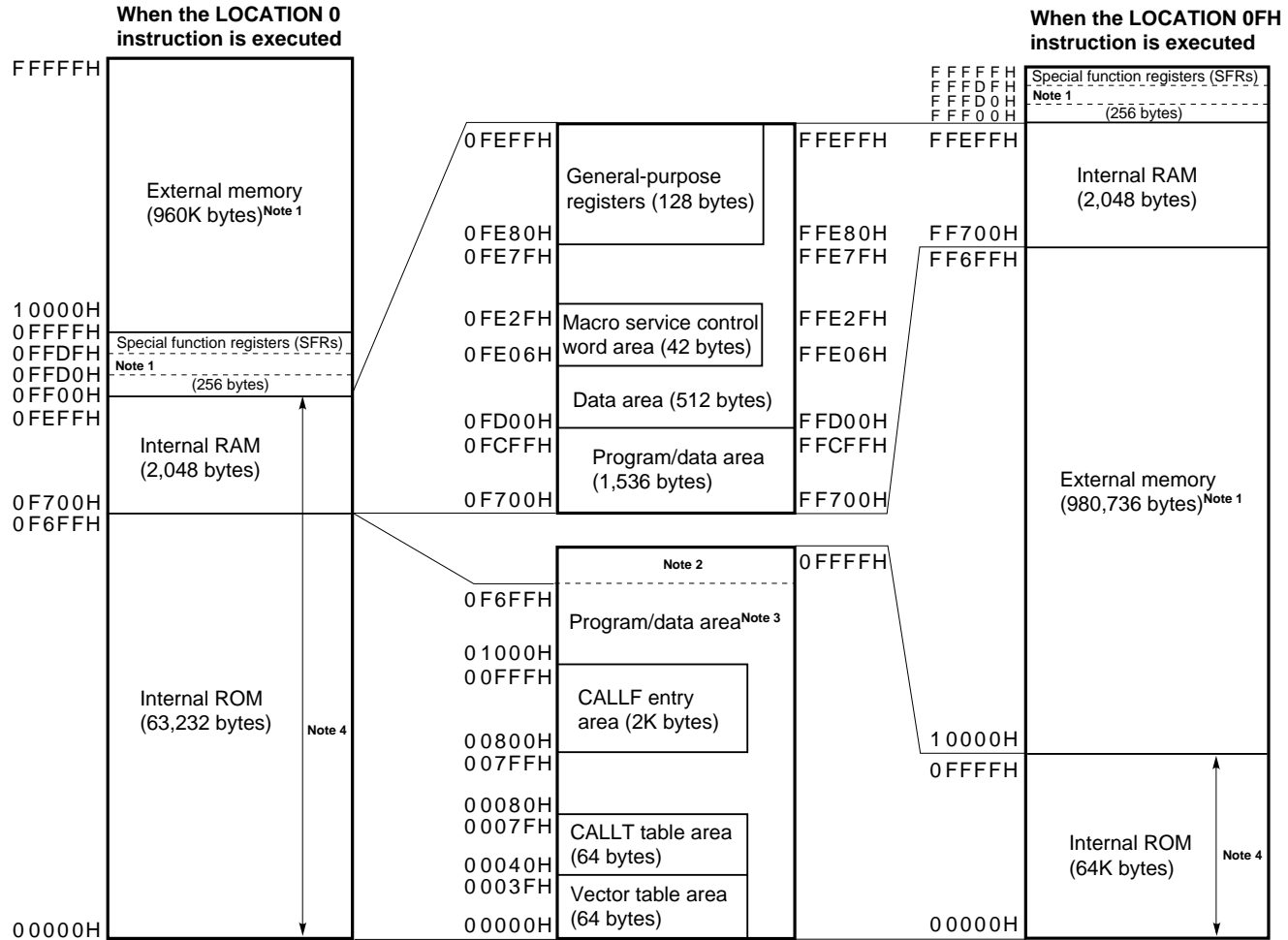
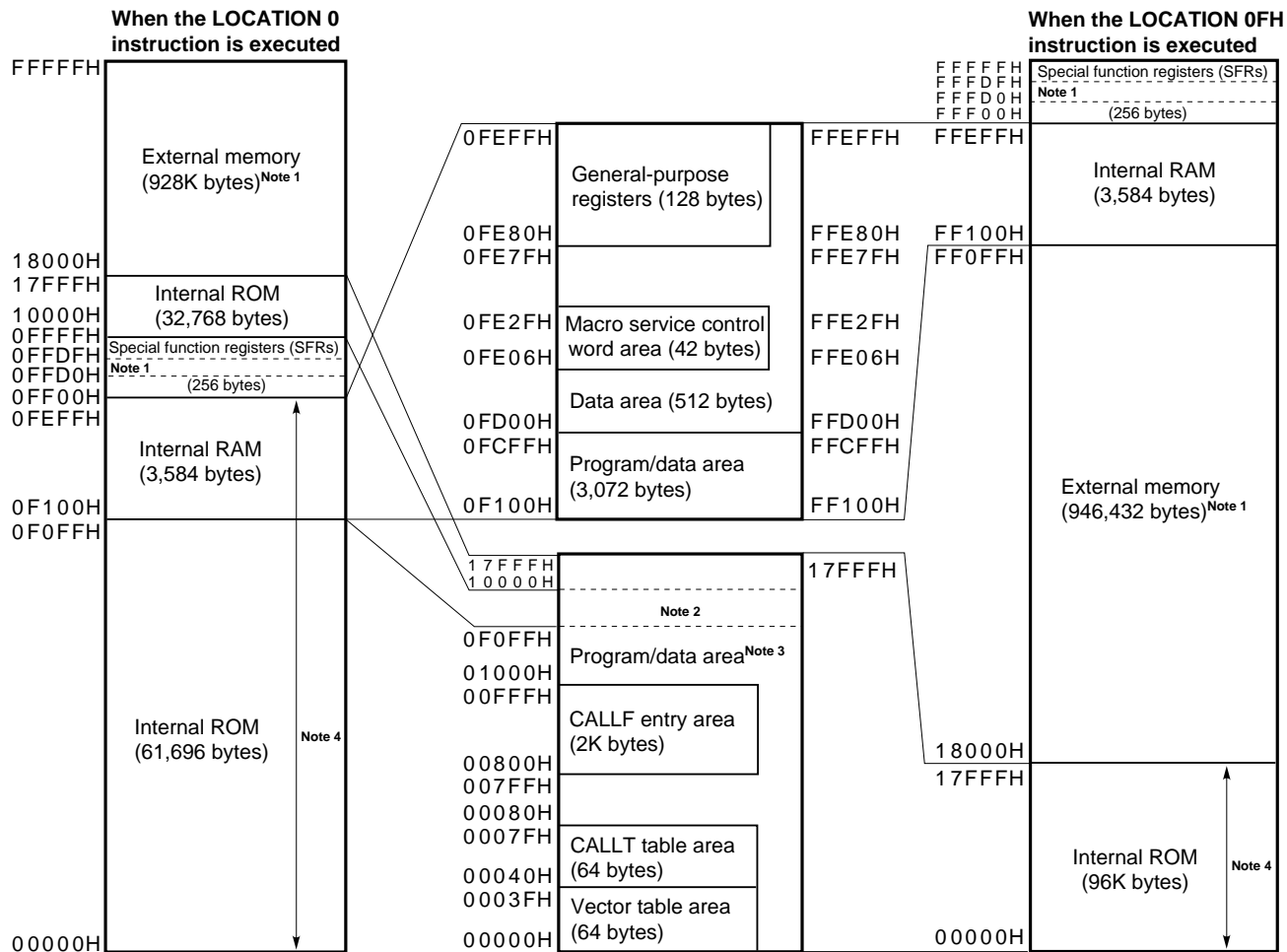
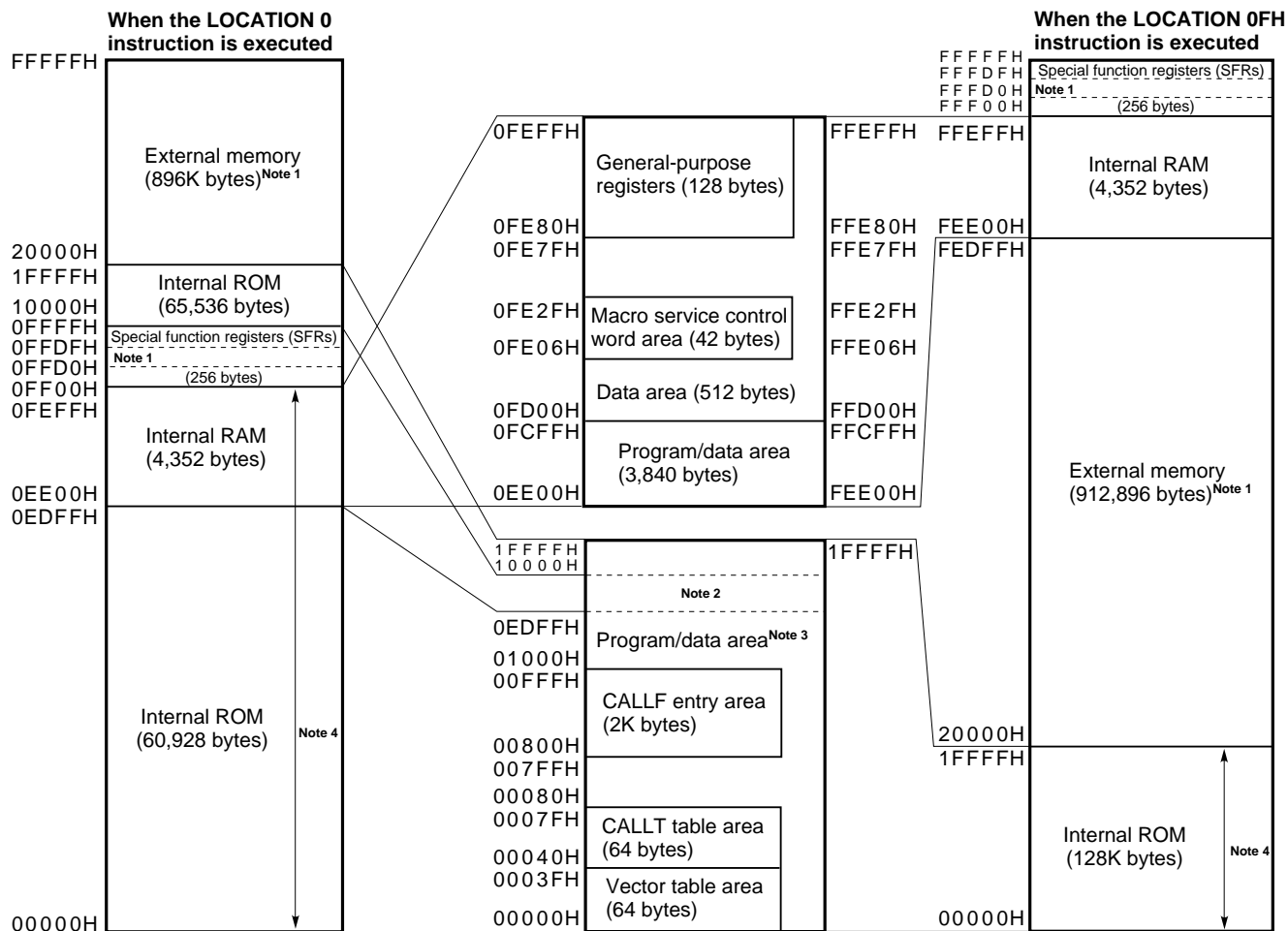

Figure 7-3. μPD784037 Memory Map



- Notes**
1. Accessed in external memory expansion mode.
  2. This 3,840-byte area can be used as an internal ROM area only when the LOCATION 0FH instruction is executed.
  3. When the LOCATION 0 instruction is executed : 94,464 bytes  
When the LOCATION 0FH instruction is executed: 98,304 bytes
  4. Base area, or entry area based on a reset or interrupt. Internal RAM is excluded in the case of a reset.

Figure 7-4.  $\mu$ PD784038 Memory Map



7.2 CPU Registers

7.2.1 General-purpose registers

A set of general-purpose registers consists of sixteen general-purpose 8-bit registers. Two 8-bit general-purpose registers can be combined to form a 16-bit general-purpose register. Moreover, four 16-bit general-purpose registers, when combined with an 8-bit register for address extension, can be used as 24-bit address specification registers.

Eight banks of this register set are provided. The user can switch between banks by software or the context switching function.

General-purpose registers other than the V, U, T, and W registers used for address extension are mapped onto internal RAM.

Figure 7-5. General-Purpose Register Format

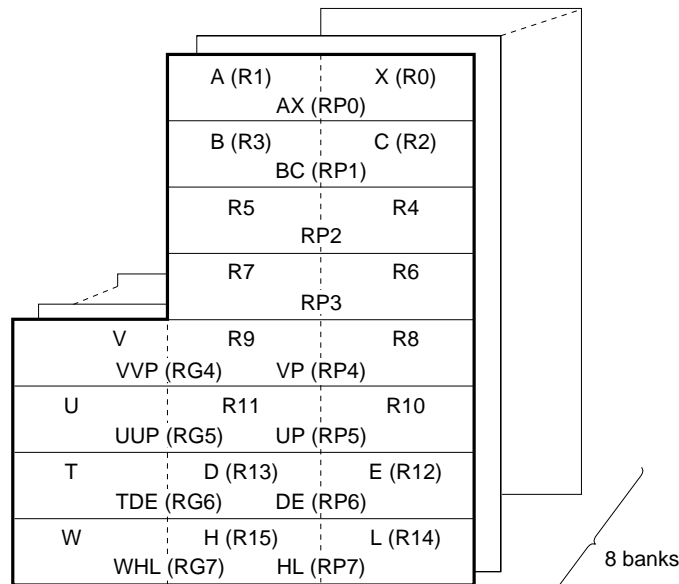

The character strings enclosed in parentheses represent absolute names.

**Caution** By setting the RSS bit of PSW to 1, R4, R5, R6, R7, RP2, and RP3 can be used as the X, A, C, B, AX, and BC registers, respectively. However, this function must be used only when using programs for the 78K/III series.

7.2.2 Control registers

(1) Program counter (PC)

This register is a 20-bit program counter. The program counter is automatically updated by program execution.

Figure 7-6. Format of Program Counter (PC)

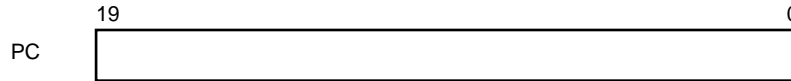

(2) Program Status Word (PSW)

This register holds the CPU state. The program status word is automatically updated by program execution.

Figure 7-7. Format of Program Status Word (PSW)

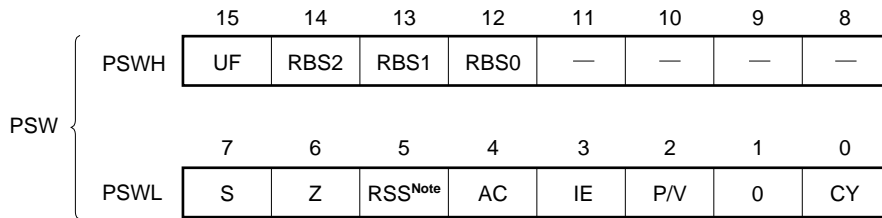

**Note** This flag is used to maintain compatibility with the 78K/III series. This flag must be set to 0 when programs for the 78K/III series are being used.

(3) Stack pointer (SP)

This register is a 24-bit pointer for holding the start address of the stack. The high-order 4 bits must be set to 0.

Figure 7-8. Format of Stack Pointer (SP)

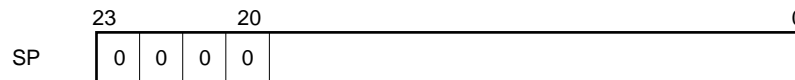

**7.2.3 Special function registers (SFRs)**

The special function registers are registers with special functions such as mode registers and control registers for built-in peripheral hardware. The special function registers are mapped onto the 256-byte space between 0FF00H and 0FFFFH<sup>Note</sup>.

**Note** Applicable when the LOCATION 0 instruction is executed. FFF00H-FFFFFH when the LOCATION 0FH instruction is executed.

**Caution** Never attempt to access addresses in this area where no SFR is allocated. Otherwise, the μPD784038 may be placed in the deadlock state. The deadlock state can be cleared only by a reset.

Table 7-1 lists the special function registers (SFRs). The titles of the table columns are explained below.

- Abbreviation ..... Symbol used to represent a built-in SFR. The abbreviations listed in the table are reserved words for the NEC assembler (RA78K4). The C compiler (CC78K4) allows the abbreviations to be used as sfr variables with the #pragma sfr command.
- R/W ..... Indicates whether each SFR allows read and/or write operations.
  - R/W : Allows both read and write operations.
  - R : Allows read operations only.
  - W : Allows write operations only.
- Manipulatable bits ..... Indicates the maximum number of bits that can be manipulated whenever an SFR is manipulated. An SFR that supports 16-bit manipulation can be described in the sfrp operand. For address specification, an even-numbered address must be specified.
  - An SFR that supports 1-bit manipulation can be described in a bit manipulation instruction.
- When reset ..... Indicates the state of each register when  $\overline{\text{RESET}}$  is applied.

Table 7-1. Special Function Registers (SFRs) (1/4)

Address <sup>Note</sup>	Special function register (SFR) name		Abbreviation	R/W	Manipulatable bits			When reset
					1 bit	8 bits	16 bits	
0FF00H	Port 0		P0	R/W	○	○	-	Undefined
0FF01H	Port 1		P1		○	○	-	
0FF02H	Port 2		P2	R	○	○	-	
0FF03H	Port 3		P3	R/W	○	○	-	
0FF04H	Port 4		P4		○	○	-	
0FF05H	Port 5		P5		○	○	-	
0FF06H	Port 6		P6		○	○	-	
0FF07H	Port 7		P7		○	○	-	Undefined
0FF0EH		Port 0 buffer register L	P0L		○	○	-	
0FF0FH	Port 0 buffer register H		P0H		○	○	-	
0FF10H	Compare register (timer/counter 0)		CR00		-	-	○	
0FF12H	Capture/compare register (timer/counter 0)		CR01		-	-	○	
0FF14H	Compare register L (timer/counter 1)		CR10	CR10W	-	○	○	
0FF15H	Compare register H (timer/counter 1)		-		-	-		
0FF16H	Capture/compare register L (timer/counter 1)		CR11	CR11W	-	○	○	
0FF17H	Capture/compare register H (timer/counter 1)		-		-	-		
0FF18H	Compare register L (timer/counter 2)		CR20	CR20W	-	○	○	
0FF19H	Compare register H (timer/counter 2)		-		-	-		
0FF1AH	Capture/compare register L (timer/counter 2)		CR21	CR21W	-	○	○	
0FF1BH	Capture/compare register H (timer/counter 2)		-		-	-		
0FF1CH	Compare register L (timer 3)		CR30	CR30W	-	○	○	
0FF1DH	Compare register H (timer 3)		-		-	-		
0FF20H	Port 0 mode register		PM0		○	○	-	FFH
0FF21H	Port 1 mode register		PM1		○	○	-	
0FF23H	Port 3 mode register		PM3		○	○	-	
0FF24H	Port 4 mode register		PM4		○	○	-	
0FF25H	Port 5 mode register		PM5		○	○	-	
0FF26H	Port 6 mode register		PM6		○	○	-	
0FF27H	Port 7 mode register		PM7		○	○	-	
0FF2EH	Real-time output port control register		RTPC		○	○	-	00H
0FF30H	Capture/compare control register 0		CRC0		-	○	-	10H
0FF31H	Timer output control register		TOC		○	○	-	00H
0FF32H	Capture/compare control register 1		CRC1		-	○	-	
0FF33H	Capture/compare control register 2		CRC2		-	○	-	10H

**Note** Applicable when the LOCATION 0 instruction is executed. When the LOCATION 0FH instruction is executed, F0000H is added to each address.

Table 7-1. Special Function Registers (SFRs) (2/4)

Address <sup>Note</sup>	Special function register (SFR) name	Abbreviation		R/W	Manipulatable bits			When reset		
					1 bit	8 bits	16 bits			
0FF36H	Capture register (timer/counter 0)	CR02		R	-	-	○	0000H		
0FF38H	Capture register L (timer/counter 1)	CR12	CR12W		-	○	○			
0FF39H	Capture register H (timer/counter 1)	-			-	-				
0FF3AH	Capture register L (timer/counter 2)	CR22	CR22W		-	○	○			
0FF3BH	Capture register H (timer/counter 2)	-			-	-				
0FF41H	Port 1 mode control register	PMC1		R/W	○	○	-	00H		
0FF43H	Port 3 mode control register	PMC3			○	○	-			
0FF4EH	Register for optional pull-up resistor	PUO			○	○	-			
0FF50H	Timer register 0	TM0		R	-	-	○	0000H		
0FF51H						-	-			
0FF52H	Timer register 1	TM1	TM1W		-	○	○			
0FF53H		-			-	-				
0FF54H	Timer register 2	TM2	TM2W		-	○	○			
0FF55H		-			-	-				
0FF56H	Timer register 3	TM3	TM3W		-	○	○			
0FF57H		-			-	-				
0FF5CH	Prescaler mode register 0	PRM0			R/W	-	○		-	11H
0FF5DH	Timer control register 0	TMC0				○	○		-	00H
0FF5EH	Prescaler mode register 1	PRM1		-		○	-	11H		
0FF5FH	Timer control register 1	TMC1		○		○	-	00H		
0FF60H	D/A conversion value setting register 0	DACS0		-		○	-			
0FF61H	D/A conversion value setting register 1	DACS1		-		○	-			
0FF62H	D/A converter mode register	DAM		○		○	-	03H		
0FF68H	A/D converter mode register	ADM		○		○	-	00H		
0FF6AH	A/D conversion result register	ADCR		R		-	○	-	Undefined	
0FF70H	PWM control register	PWMC		R/W		○	○	-	05H	
0FF71H	PWM prescaler register	PWPR			-	○	-	00H		
0FF72H	PWM modulo register 0	PWM0			-	-	○	Undefined		
0FF74H	PWM modulo register 1	PWM1			-	-	○			
0FF7DH	One-shot pulse output control register	OSPC			○	○	-	00H		
0FF80H	I <sup>2</sup> C bus control register	IICC			○	○	-			
0FF81H	Prescaler mode register for serial clock	SPRM			-	○	-	04H		
0FF82H	Synchronous serial interface mode register	CSIM			○	○	-	00H		

**Note** Applicable when the LOCATION 0 instruction is executed. When the LOCATION 0FH instruction is executed, F0000H is added to each address.

Table 7-1. Special Function Registers (SFRs) (3/4)

Address <sup>Note 1</sup>	Special function register (SFR) name	Abbreviation	R/W	Manipulatable bits			When reset		
				1 bit	8 bits	16 bits			
0FF84H	Synchronous serial interface mode register 1	CSIM1	R/W	○	○	-	00H		
0FF85H	Synchronous serial interface mode register 2	CSIM2		○	○	-			
0FF86H	Serial shift register	SIO		-	○	-			
0FF88H	Asynchronous serial interface mode register	ASIM		○	○	-			
0FF89H	Asynchronous serial interface mode register 2	ASIM2		○	○	-			
0FF8AH	Asynchronous serial interface status register	ASIS	R	○	○	-	Undefined		
0FF8BH	Asynchronous serial interface status register 2	ASIS2		○	○	-			
0FF8CH	Serial receive buffer: UART0	RXB	W	-	○	-			
	Serial transmission shift register: UART0	TXS		-	○	-			
	Serial shift register: IOE1	SIO1		R/W	-	○		-	
0FF8DH	Serial receive buffer: UART2	RXB2	R	-	○	-			
	Serial transmission shift register: UART2	TXS2	W	-	○	-			
	Serial shift register: IOE2	SIO2	R/W	-	○	-			
0FF90H	Baud rate generator control register	BRGC	R	-	○	-		00H	
0FF91H	Baud rate generator control register 2	BRGC2		-	○	-			
0FFA0H	External interrupt mode register 0	INTM0		○	○	-			
0FFA1H	External interrupt mode register 1	INTM1		○	○	-			
0FFA4H	Sampling clock selection register	SCS0		-	○	-			
0FFA8H	In-service priority register	ISPR	R	○	○	-		80H	
0FFAAH	Interrupt mode control register	IMC	R/W	○	○	-			
0FFACH	Interrupt mask register 0L	MK0L		MK0	○	○			○
0FFADH	Interrupt mask register 0H	MK0H			○	○			
0FFAEH	Interrupt mask register 1L	MK1L			○	○			-
0FFC0H	Standby control register	STBC			-	○ <sup>Note 2</sup>			-
0FFC2H	Watchdog timer mode register	WDM			-	○ <sup>Note 2</sup>			-
0FFC4H	Memory expansion mode register	MM			○	○	-		
0FFC5H	Hold mode register	HLDM			○	○	-		
0FFC6H	Clock output mode register	CLOM			○	○	-		
0FFC7H	Programmable wait control register 1	PWC1			-	○	-		
0FFC8H	Programmable wait control register 2	PWC2			-	-	○		

**Notes 1.** Applicable when the LOCATION 0 instruction is executed. When the LOCATION 0FH instruction is executed, F0000H is added to each address.

**2.** A write operation can be performed only with special instructions MOV STBC,#byte and MOV WDM,#byte. Other instructions cannot perform a write operation.

Table 7-1. Special Function Registers (SFRs) (4/4)

Address <sup>Note</sup>	Special function register (SFR) name	Abbreviation	R/W	Manipulatable bits			When reset
				1 bit	8 bits	16 bits	
0FFCCH	Refresh mode register	RFM	R/W	○	○	-	00H
0FFCDH	Refresh area specification register	RFA		○	○	-	
0FFCFH	Oscillation settling time specification register	OSTS		-	○	-	
0FFD0H- 0FFDFH	External SFR area	-		○	○	-	-
0FFE0H	Interrupt control register (INTP0)	PIC0		○	○	-	43H
0FFE1H	Interrupt control register (INTP1)	PIC1		○	○	-	
0FFE2H	Interrupt control register (INTP2)	PIC2		○	○	-	
0FFE3H	Interrupt control register (INTP3)	PIC3		○	○	-	
0FFE4H	Interrupt control register (INTC00)	CIC00		○	○	-	
0FFE5H	Interrupt control register (INTC01)	CIC01		○	○	-	
0FFE6H	Interrupt control register (INTC10)	CIC10		○	○	-	
0FFE7H	Interrupt control register (INTC11)	CIC11		○	○	-	
0FFE8H	Interrupt control register (INTC20)	CIC20		○	○	-	
0FFE9H	Interrupt control register (INTC21)	CIC21		○	○	-	
0FFEAH	Interrupt control register (INTC30)	CIC30		○	○	-	
0FFEBH	Interrupt control register (INTP4)	PIC4		○	○	-	
0FFECH	Interrupt control register (INTP5)	PIC5		○	○	-	
0FFEDH	Interrupt control register (INTAD)	ADIC		○	○	-	
0FFEEH	Interrupt control register (INTSER)	SERIC		○	○	-	
0FFEFH	Interrupt control register (INTSR)	SRIC		○	○	-	
	Interrupt control register (INTCS1)	CSIC1	○	○	-		
0FFF0H	Interrupt control register (INTST)	STIC	○	○	-		
0FFF1H	Interrupt control register (INTCSI)	CSIC	○	○	-		
0FFF2H	Interrupt control register (INTSER2)	SERIC2	○	○	-		
0FFF3H	Interrupt control register (INTSR2)	SRIC2	○	○	-		
	Interrupt control register (INTCS12)	CSIC2	○	○	-		
0FFF4H	Interrupt control register (INTST2)	STIC2	○	○	-		

**Note** Applicable when the LOCATION 0 instruction is executed. When the LOCATION 0FH instruction is executed, F000H is added to each address.

8. PERIPHERAL HARDWARE FUNCTIONS

8.1 Ports

The ports shown in Figure 8-1 are provided to enable the application of wide-ranging control. Table 8-1 lists the functions of the ports. For the inputs to port 0 to port 6, a built-in pull-up resistor can be specified by software.

Figure 8-1. Port Configuration

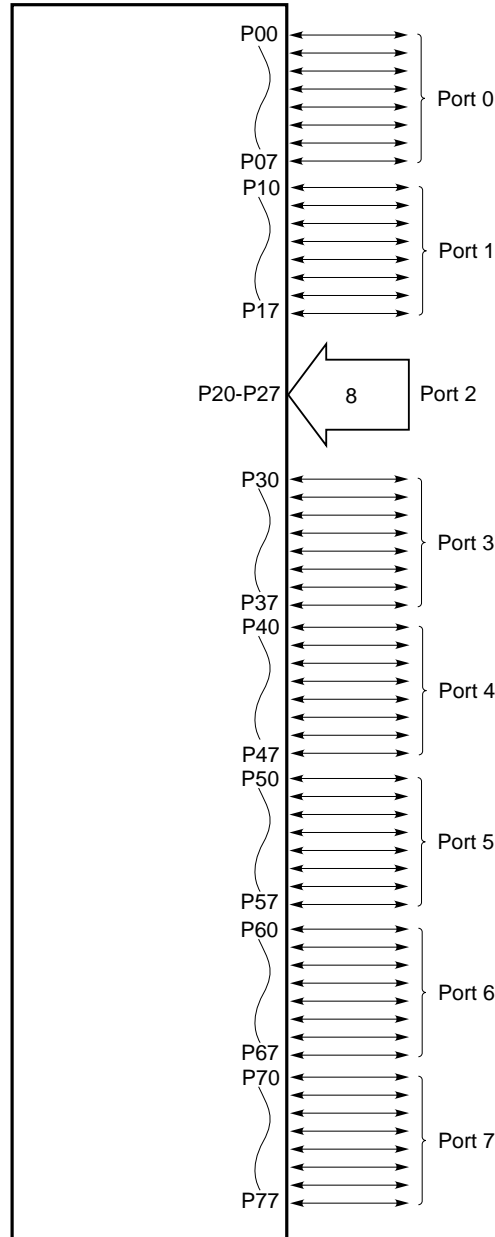



**Table 8-1. Port Functions**

Port name	Pin	Function	Pull-up specification by software
Port 0	P00-P07	<ul style="list-style-type: none"> <li>• Bit-by-bit input/output setting supported</li> <li>• Operable as 4-bit real-time outputs (P00-P03, P04-P07)</li> <li>• Capable of driving transistors</li> </ul>	Specified as a batch for all pins placed in input mode.
Port 1	P10-P17	<ul style="list-style-type: none"> <li>• Bit-by-bit input/output setting supported</li> <li>• Capable of driving LEDs</li> </ul>	Specified as a batch for all pins placed in input mode.
Port 2	P20-P27	• Input port	Specified for the 6 bits (P22-P27) as a batch.
Port 3	P30-P37	• Bit-by-bit input/output setting supported	Specified as a batch for all pins placed in input mode.
Port 4	P40-P47	<ul style="list-style-type: none"> <li>• Bit-by-bit input/output setting supported</li> <li>• Capable of driving LEDs</li> </ul>	Specified as a batch for all pins placed in input mode.
Port 5	P50-P57	<ul style="list-style-type: none"> <li>• Bit-by-bit input/output setting supported</li> <li>• Capable of driving LEDs</li> </ul>	Specified as a batch for all pins placed in input mode.
Port 6	P60-P67	• Bit-by-bit input/output setting supported	Specified as a batch for all pins placed in input mode.
Port 7	P70-P77	• Bit-by-bit input/output setting supported	-

**8.2 Clock Generator**

A circuit for generating the clock signal required for operation is provided. The clock generator includes a frequency divider; low current consumption can be achieved by operating at a lower internal frequency when high-speed operation is not necessary.

**Figure 8-2. Block Diagram of Clock Generator**

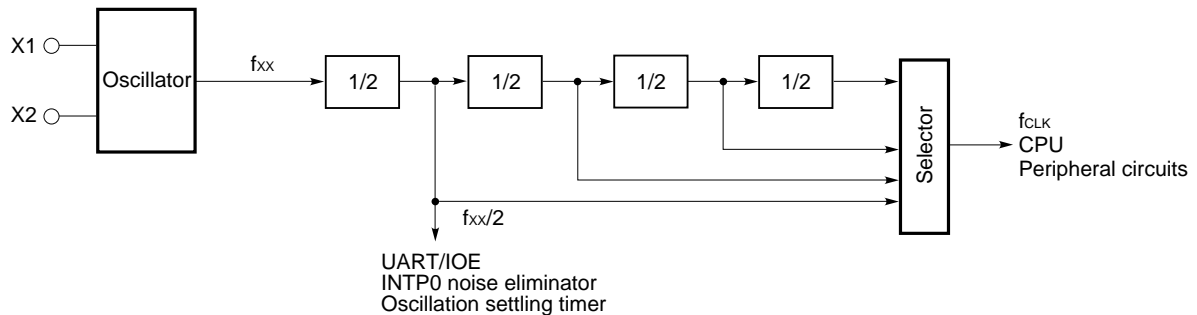

**Remark**  $f_{xx}$  : Oscillator frequency or external clock input frequency  
 $f_{CLK}$ : Internal operating frequency

Figure 8-3. Examples of Using Oscillator

(1) Crystal/ceramic oscillation

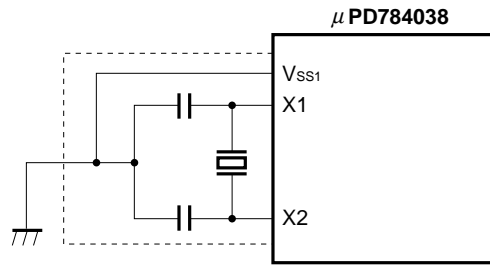

(2) External clock

- When EXTC bit of OSTS = 1

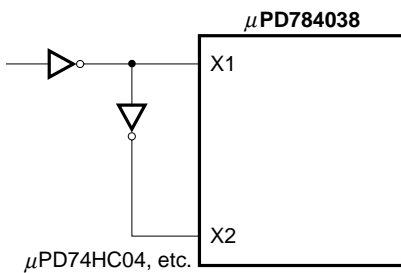

- When EXTC bit of OSTS = 0

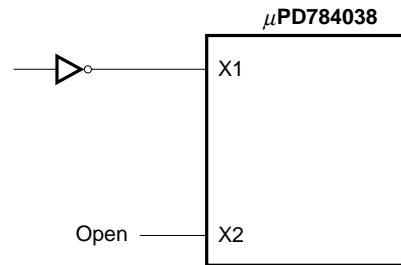

**Caution** When using the system clock generator, run wires in the portion surrounded by broken lines according to the following rules to avoid effects such as stray capacitance:

- Minimize the wiring.
- Never cause the wires to cross other signal lines.
- Never cause the wires to run near a line carrying a large varying current.
- Cause the grounding point of the capacitor of the oscillator circuit to have the same potential as V<sub>SS1</sub>. Never connect the capacitor to a ground pattern carrying a large current.
- Never extract a signal from the oscillator.

**8.3 Real-Time Output Port**

The real-time output port outputs data stored in the buffer, synchronized with a timer/counter 1 match interrupt or external interrupt. Thus, pulse output that is free of jitter can be obtained.

Therefore, the real-time output port is best suited to applications (such as open-loop control over stepping motors) where an arbitrary pattern is output at arbitrary intervals.

As shown in Figure 8-4, the real-time output port is built around port 0 and the port 0 buffer register (P0H, P0L).

**Figure 8-4. Block Diagram of Real-Time Output Port**

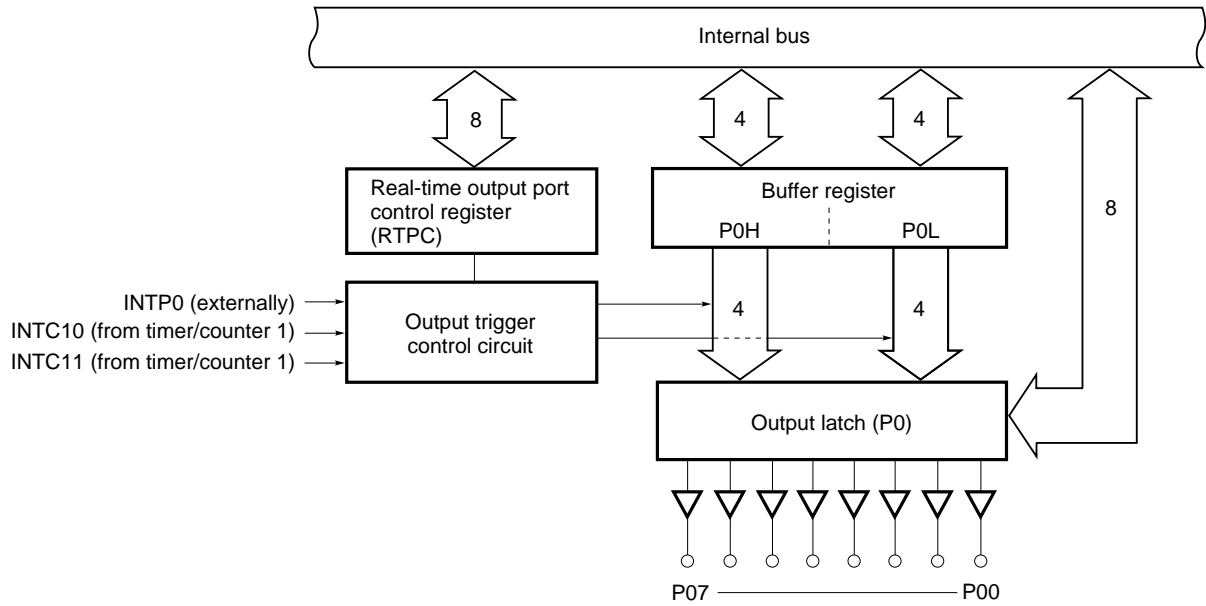

8.4 Timers/Counters

Three timer/counter units and one timer unit are incorporated.

Moreover, seven interrupt requests are supported, allowing these units to function as seven timer/counter units.

Table 8-2. Timer/Counter Operation

Name		Timer/counter 0	Timer/counter 1	Timer/counter 2	Timer 3
Item					
Count pulse width	8 bits	-	○	○	○
	16 bits	○	○	○	○
Operating mode	Interval timer	2ch	2ch	2ch	1ch
	External event counter	○	○	○	-
	One-shot timer	-	-	○	-
Function	Timer output	2ch	-	2ch	-
	Toggle output	○	-	○	-
	PWM/PPG output	○	-	○	-
	One-shot pulse output <sup>Note</sup>	○	-	-	-
	Real-time output	-	○	-	-
	Pulse width measurement	1 input	1 input	2 inputs	-
	Number of interrupt requests	2	2	2	1

**Note** The one-shot pulse output function makes the level of a pulse output active by software, and makes the level of a pulse output inactive by hardware (interrupt request signal).

Note that this function differs from the one-shot timer function of timer/counter 2.

Figure 8-5. Timer/Counter Block Diagram

Timer/counter 0

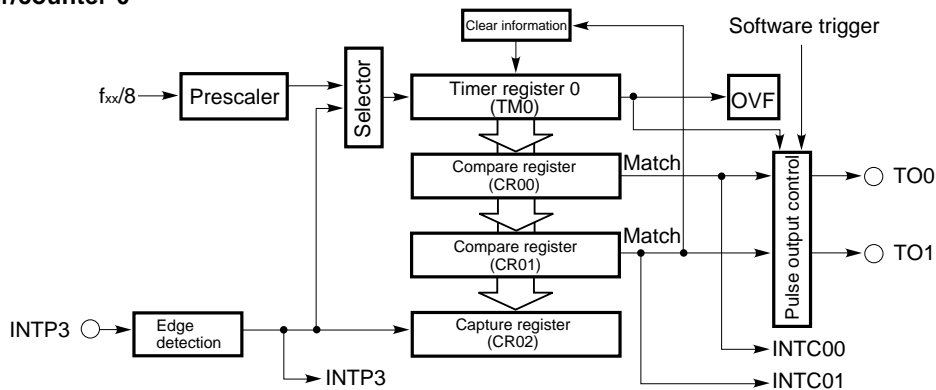

Timer/counter 1

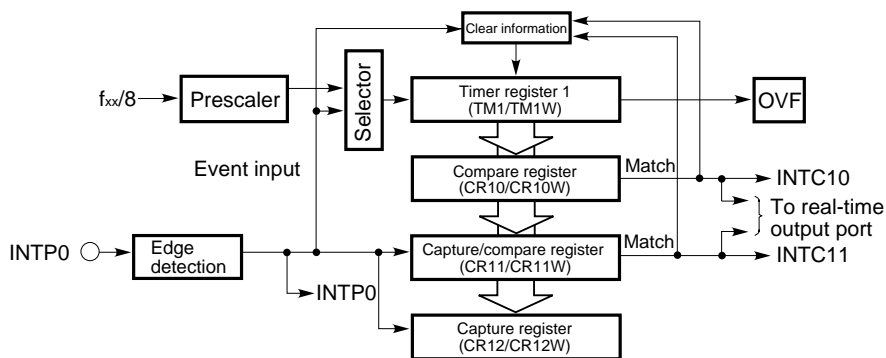

Timer/counter 2

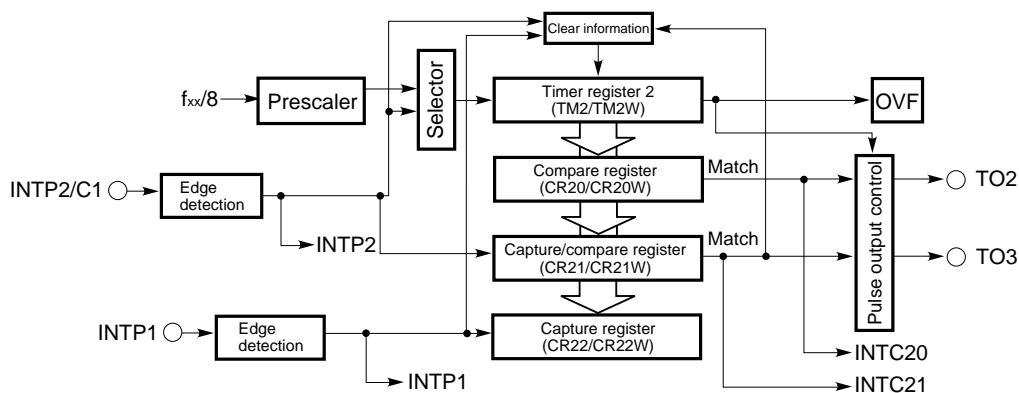

Timer 3

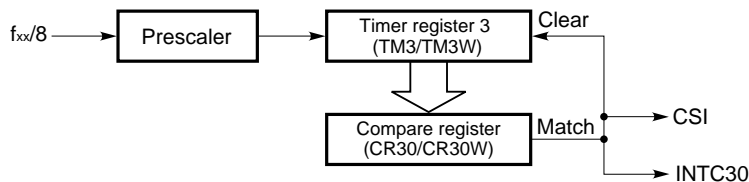

Remark OVF: Overflow flag

**8.5 PWM Output (PWM0, PWM1)**

Two channels of PWM (pulse width modulation) output circuitry with a resolution of 12 bits and a repetition frequency of 62.5 kHz ( $f_{CLK} = 16 \text{ MHz}$ ) are incorporated. Low or high active level can be selected for the PWM output channels, independently of each other. This output is best suited to DC motor speed control.

**Figure 8-6. Block Diagram of PWM Output Unit**

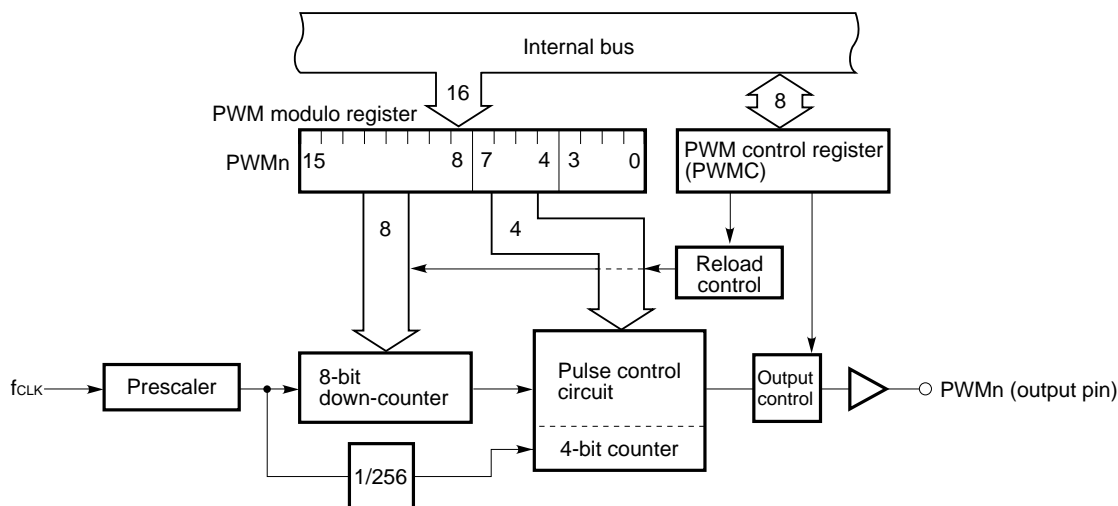

**Remark** n = 0, 1

**8.6 A/D Converter**

An analog/digital (A/D) converter having 8 multiplexed analog inputs (ANI0-ANI7) is incorporated.

The successive approximation system is used for conversion. The result of conversion is held in the 8-bit A/D conversion result register (ADCR). Thus, speedy high-precision conversion can be achieved. (The conversion time is about 7.5  $\mu$ s at  $f_{CLK} = 16$  MHz.)

A/D conversion can be started in any of the following modes:

- Hardware start: Conversion is started by means of trigger input (INTP5).
- Software start : Conversion is started by means of bit setting the A/D converter mode register (ADM).

After conversion has started, one of the following modes can be selected:

- Scan mode : Multiple analog inputs are selected sequentially to obtain conversion data from all pins.
- Select mode: A single analog input is selected at all times to enable conversion data to be obtained continuously.

ADM is used to specify the above modes, as well as the termination of conversion.

When the result of conversion is transferred to ADCR, an interrupt request (INTAD) is generated. Using this feature, the results of conversion can be continuously transferred to memory by the macro service.

**Figure 8-7. Block Diagram of A/D Converter**

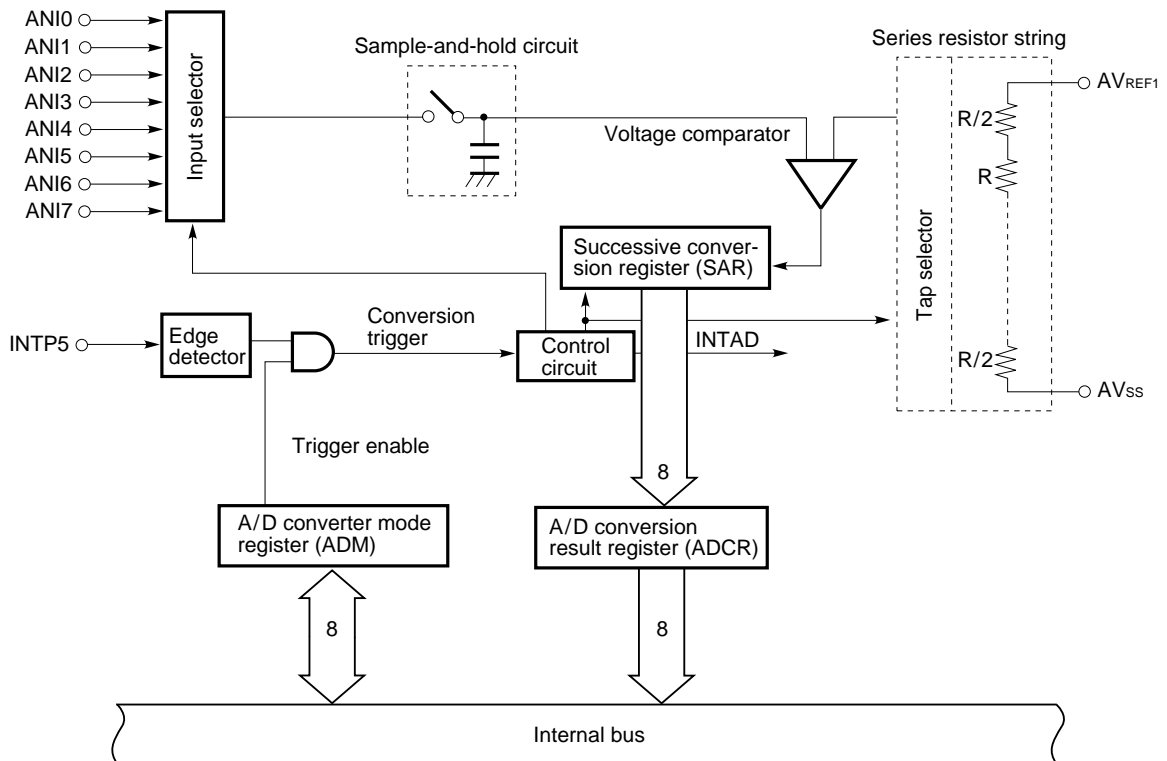

**8.7 D/A Converter**

Two digital/analog (D/A) converter channels of voltage output type, having a resolution of 8 bits, are incorporated.

An R-2R resistor ladder system is used for conversion. By writing the value to be subject to D/A conversion in the 8-bit D/A conversion value setting register (DACSn: n = 0, 1), the resulting analog value is output on ANOn (n = 0, 1). The range of the output voltages is determined by the voltages applied to the AVREF2 and AVREF3 pins.

Because of its high output impedance, no current can be obtained from an output pin. When the load impedance is low, insert a buffer amplifier between the load and the converter.

The impedance of the ANOn pin goes high while the  $\overline{\text{RESET}}$  signal is low. DACSn is set to 0 after a reset is released.

**Figure 8-8. Block Diagram of D/A Converter**

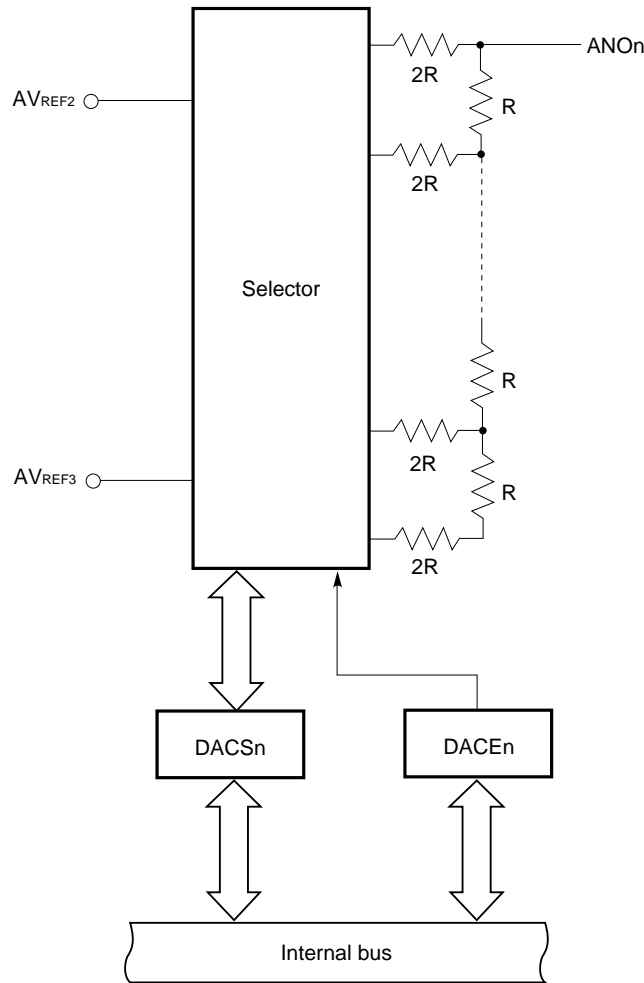

**Remark** n = 0, 1



**8.8 Serial Interface**

Three independent serial interface channels are incorporated.

- Asynchronous serial interface (UART)/three-wire serial I/O (IOE) × 2
- Synchronous serial interface (CSI) × 1
  - Three-wire serial I/O (IOE)
  - Two-wire serial I/O (IOE)

So, communication with points external to the system and local communication within the system can be performed at the same time. (See **Figure 8-9.**)

**Figure 8-9. Example Serial Interfaces**

**UART + Three-wire serial I/O + Two-wire serial I/O**

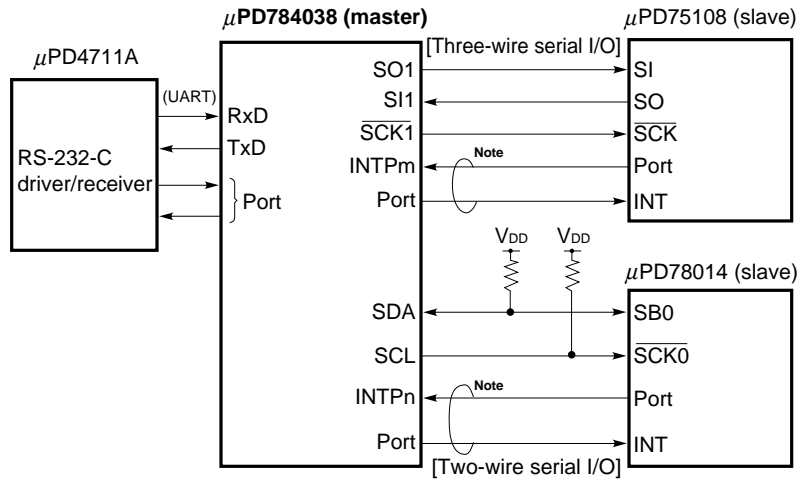

**Note** Handshake line

**8.8.1 Asynchronous serial interface/three-wire serial I/O (UART/IOE)**

Two serial interface channels are available; for each channel, asynchronous serial interface mode or three-wire serial I/O mode can be selected.

**(1) Asynchronous serial interface mode**

In this mode, 1-byte data is transferred after a start bit.

A baud rate generator is incorporated to enable communication at a wide range of baud rates.

Moreover, the frequency of a clock signal applied to the ASCK pin can be divided to define a baud rate.

With the baud rate generator, the baud rate conforming to the MIDI standard (31.25 kbps) can be obtained.

**Figure 8-10. Block Diagram of Asynchronous Serial Interface Mode**

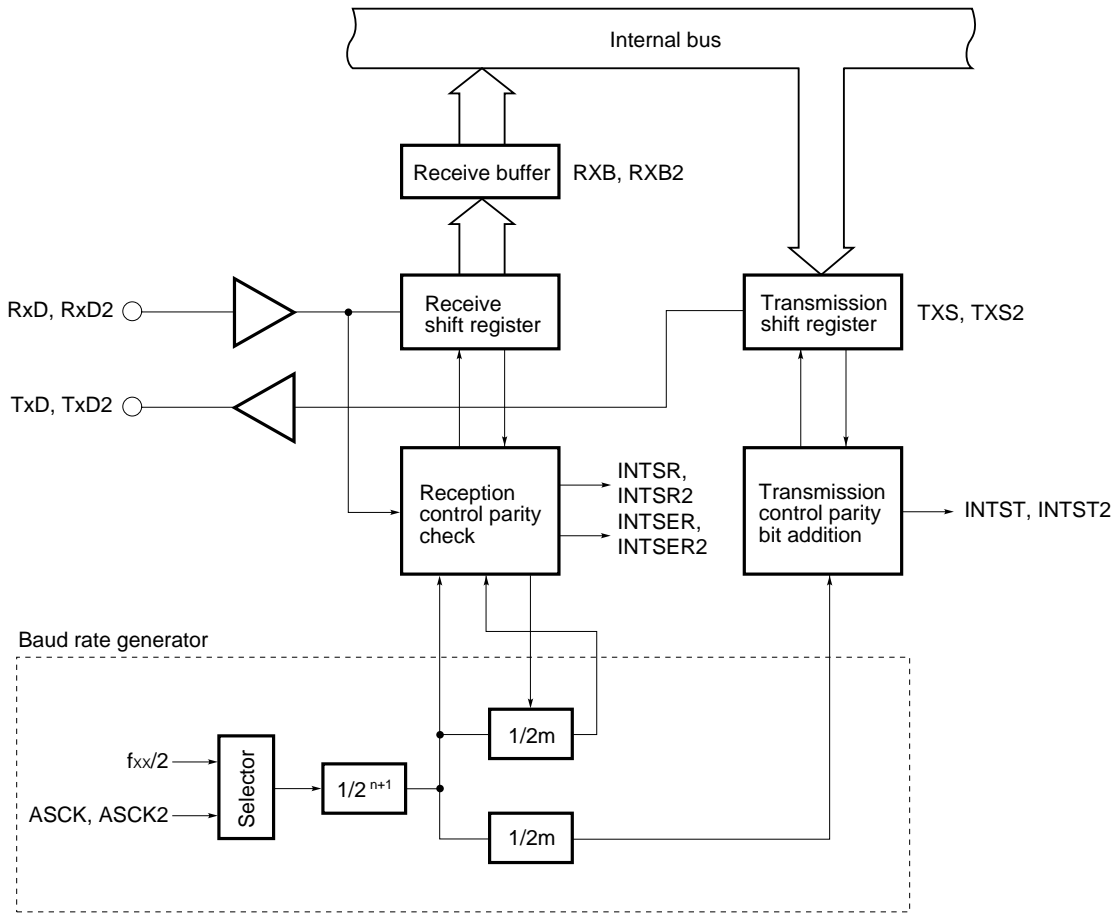

**Remark** f<sub>xx</sub>: Oscillator frequency or external clock input frequency  
 n = 0 to 11  
 m = 16 to 30

**(2) Three-wire serial I/O mode**

In this mode, the master device makes the serial clock active to start transmission, then transfers 1-byte data in phase with the clock.

This mode is designed for communication with a device incorporating a conventional synchronous serial interface. Basically, three lines are used for communication: the serial clock line ( $\overline{SCK}$ ) and the two serial data lines (SI and SO).

In general, a handshake line is required to check the communication state.

**Figure 8-11. Block Diagram of Three-Wire Serial I/O Mode**

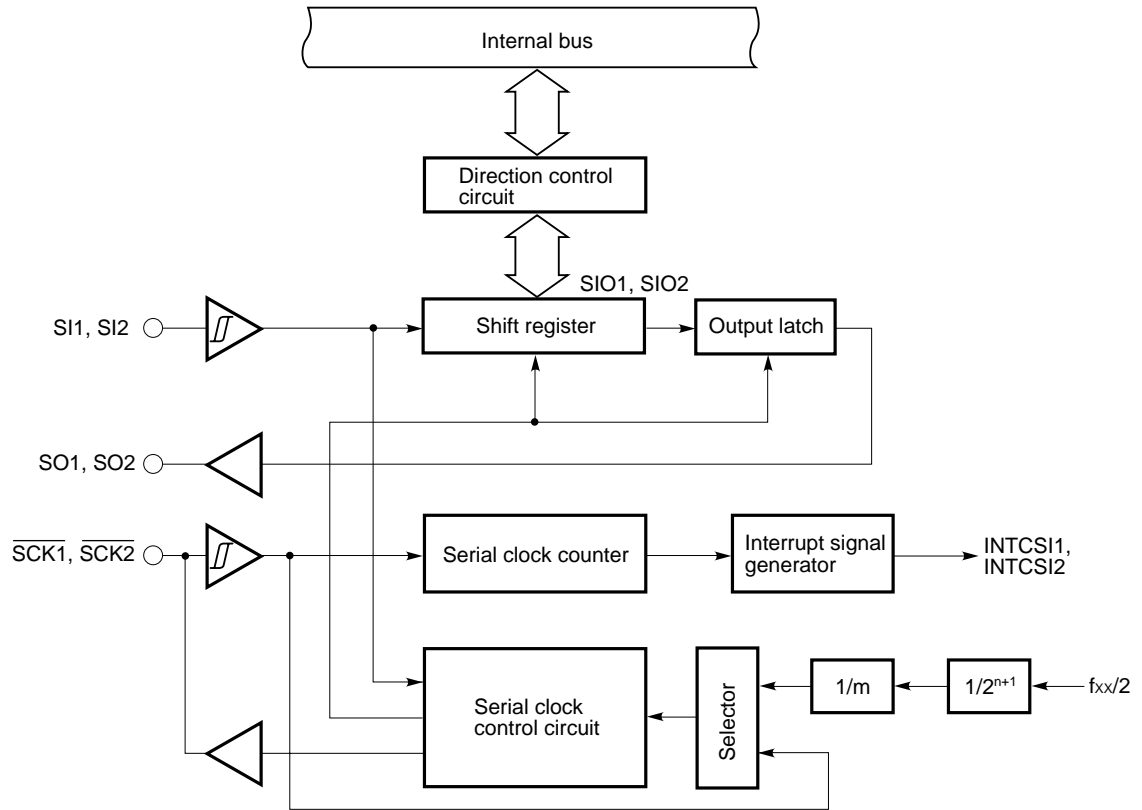

**Remark**  $f_{xx}$ : Oscillator frequency or external clock input frequency  
 $n = 0$  to  $11$   
 $m = 1, 16$  to  $30$

### 8.8.2 Synchronous serial interface (CSI)

With this interface, the master device makes the serial clock active to start transmission, then transfers 1-byte data in phase with the clock.

Figure 8-12. Block Diagram of Synchronous Serial Interface

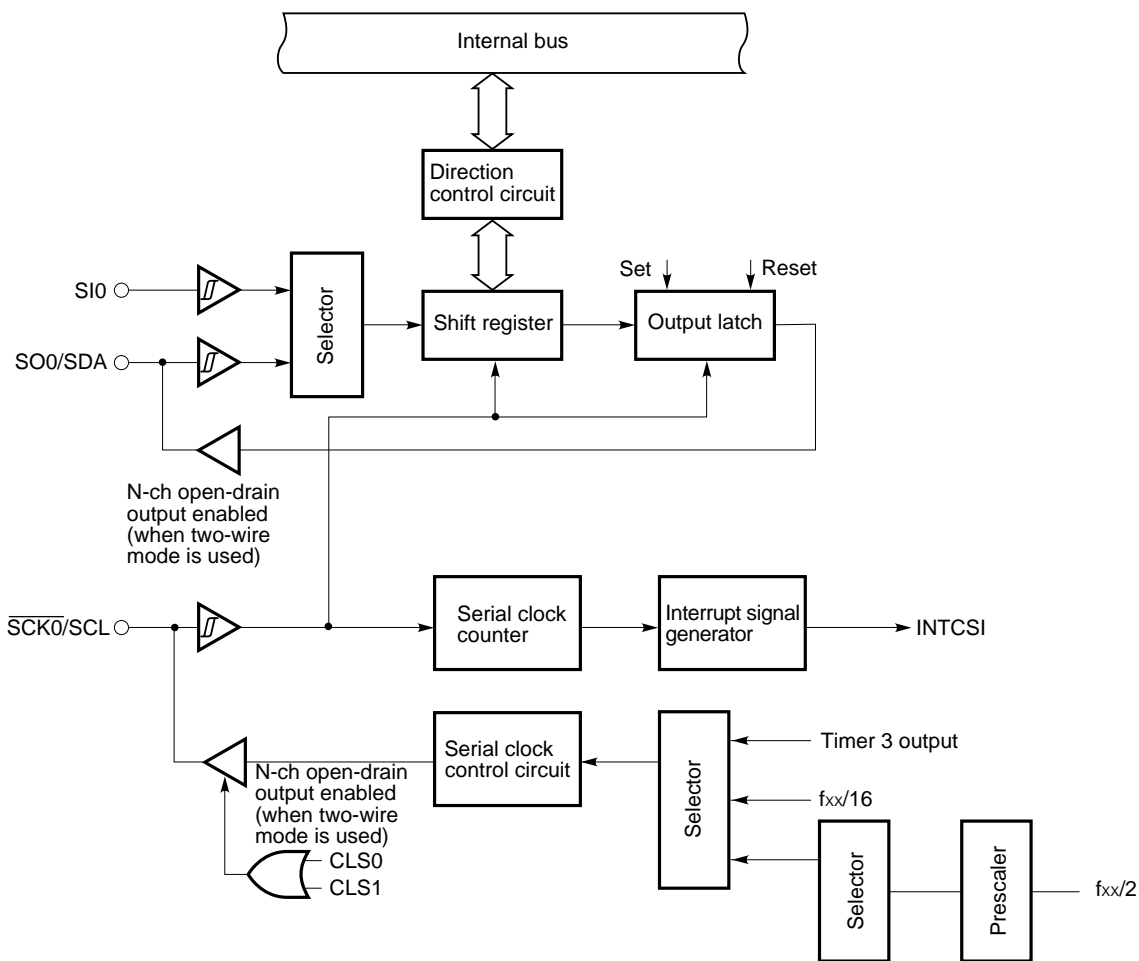

**Remark** f<sub>xx</sub>: Oscillator frequency or external clock input frequency

**(1) Three-wire serial I/O mode**

This mode is designed for communication with a device incorporating a conventional synchronous serial interface. Basically, three lines are used for communication: the serial clock line ( $\overline{\text{SCK0}}$ ) and serial data lines (SI0 and SO0). In general, a handshake line is required to check the communication state.

**(2) Two-wire serial I/O mode**

In this mode, 8-bit data is transferred using two lines: the serial clock line (SCL) and serial data bus (SDA). In general, a handshake line is required to check the communication state.

**8.9 Clock Output Function**

The frequency of the CPU clock signal can be divided for output to a point external to the system. Moreover, the port can be used as a 1-bit port.

The ASTB pin is also used for the CLKOUT pin, so that when this function is used, the local bus interface cannot be used.

**Figure 8-13. Block Diagram of Clock Output Function**

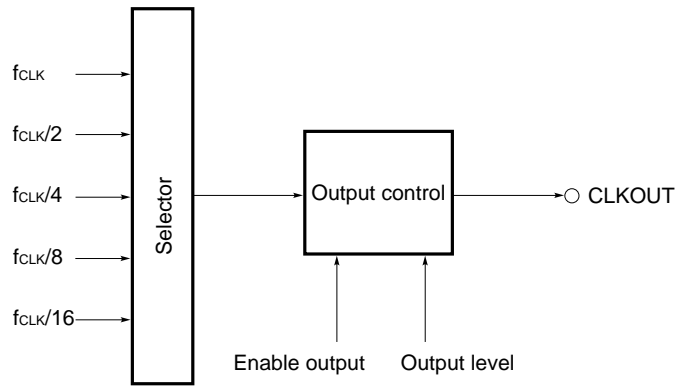

**8.10 Edge Detection Function**

The interrupt input pins (NMI, INTP0-INTP5) are used to apply not only interrupt requests but also trigger signals for the built-in circuits. As these pins are triggered by an edge (rising or falling) of an input signal, a function for edge detection is incorporated. Moreover, a noise suppression function is provided to prevent erroneous edge detection caused by noise.

Pin	Detectable edge	Noise suppression method
NMI	Rising edge or falling edge	Analog delay
INTP0-INTP3	Rising edge or falling edge, or both edges	Clock sampling <sup>Note</sup>
INTP4, INTP5		Analog delay

**Note** INTP0 is used for sampling clock selection.

**8.11 Watchdog Timer**

A watchdog timer is incorporated for CPU runaway detection. The watchdog timer, if not cleared by software within a specified interval, generates a nonmaskable interrupt. Furthermore, once watchdog timer operation is enabled, it cannot be disabled by software. The user can specify whether priority is placed on an interrupt based on the watchdog timer or on an interrupt based on the NMI pin.

**Figure 8-14. Block Diagram of Watchdog Timer**

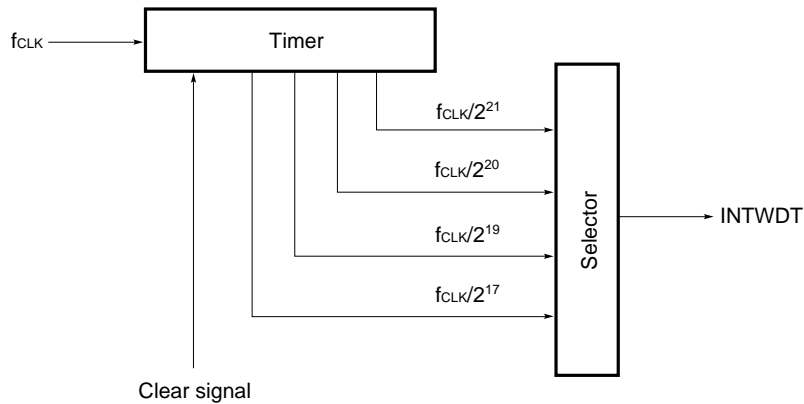

**9. INTERRUPT FUNCTION**

Table 9-1 lists the interrupt request handling modes. These modes are selected by software.

**Table 9-1. Interrupt Request Handling Modes**

Handling mode	Handled by	Handling	PC and PSW contents
Vectored interrupt	Software	Branches to a handling routine for execution (arbitrary handling).	The PC and PSW contents are pushed to and popped from the stack.
Context switching		Automatically selects a register bank, and branches to a handling routine for execution (arbitrary handling).	The PC and PSW contents are saved to and read from a fixed area in the register bank.
Macro service	Firmware	Performs operations such as memory-to-I/O-device data transfer (fixed handling).	Maintained

**9.1 Interrupt Source**

An interrupt can be issued from any one of the interrupt sources listed in Table 9-2: execution of a BRK instruction and BRKCS instruction, an operand error, or any of the 23 other interrupt sources.

Four levels of interrupt handling priority can be set. Priority levels can be set to nest control during interrupt handling or to concurrently generate interrupt requests. Nested macro services, however, are performed without suspension.

When interrupt requests having the same priority level are generated, they are handled according to the default priority (fixed). (See **Table 9-2.**)

Table 9-2. Interrupt Sources

Type	Default priority	Source		Internal/external	Macro service		
		Name	Trigger				
Software	-	BRK instruction	Instruction execution	-	-		
		BRKCS instruction					
		Operand error	When the MOV STBC,#byte, MOV WDM,#byte, or LOCATION instruction is executed, exclusive OR of the byte operand and byte does not produce FFH.				
Nonmaskable	-	NMI	Detection of edge input on the pin	External	-		
		WDT	Watchdog timer overflow	Internal			
Maskable	0 (highest)	INTP0	Detection of edge input on the pin (TM1/TM1W capture trigger, TM1/TM1W event counter input)	External	Enabled		
	1	INTP1	Detection of edge input on the pin (TM2/TM2W capture trigger, TM2/TM2W event counter input)				
	2	INTP2	Detection of edge input on the pin (TM2/TM2W capture trigger, TM2/TM2W event counter input)				
	3	INTP3	Detection of edge input on the pin (TM0 capture trigger, TM0 event counter input)				
	4	INTC00	TM0-CR00 match signal issued	Internal	Enabled		
	5	INTC01	TM0-CR01 match signal issued				
	6	INTC10	TM1-CR10 match signal issued (in 8-bit operation mode) TM1W-CR10W match signal issued (in 16-bit operation mode)				
	7	INTC11	TM1-CR11 match signal issued (in 8-bit operation mode) TM1W-CR11W match signal issued (in 16-bit operation mode)				
	8	INTC20	TM2-CR20 match signal issued (in 8-bit operation mode) TM2W-CR20W match signal issued (in 16-bit operation mode)				
	9	INTC21	TM2-CR21 match signal issued (in 8-bit operation mode) TM2W-CR21W match signal issued (in 16-bit operation mode)				
	10	INTC30	TM3-CR30 match signal issued (in 8-bit operation mode) TM3W-CR30W match signal issued (in 16-bit operation mode)				
	11	INTP4	Detection of edge input on the pin			External	Enabled
	12	INTP5	Detection of edge input on the pin				
	13	INTAD	A/D converter processing completed (ADCR transfer)			Internal	Enabled
	14	INTSER	ASI0 reception error	-			
	15	INTSR	ASI0 reception completed or CSI1 transfer completed	Enabled			
		INTCSI1					
	16	INTST	ASI0 transmission completed	Enabled			
	17	INTCSI	CSI0 transfer completed				
	18	INTSER2	ASI2 reception error	-			
19	INTSR2	ASI2 reception completed or CSI2 transfer completed	Enabled				
	INTCSI2						
20 (lowest)	INTST2	ASI2 transmission completed					

**Remark** ASI: Asynchronous serial interface  
 CSI: Synchronous serial interface



**9.2 Vectored Interrupt**

When a branch to an interrupt handling routine occurs, the vector table address corresponding to the interrupt source is used as the branch address.

Interrupt handling by the CPU consists of the following operations :

- When a branch occurs : Push the CPU status (PC and PSW contents) to the stack.
- When control is returned: Pop the CPU status (PC and PSW contents) from the stack.

To return control from the handling routine to the main routine, use the RETI instruction. The branch destination addresses must be within the range of 0 to FFFFH.

**Table 9-3. Vector Table Address**

Interrupt source	Vector table address
BRK instruction	003EH
Operand error	003CH
NMI	0002H
WDT	0004H
INTP0	0006H
INTP1	0008H
INTP2	000AH
INTP3	000CH
INTC00	000EH
INTC01	0010H
INTC10	0012H
INTC11	0014H
INTC20	0016H
INTC21	0018H
INTC30	001AH
INTP4	001CH
INTP5	001EH
INTAD	0020H
INTSER	0022H
INTSR	0024H
INTCSI1	
INTST	0026H
INTCSI	0028H
INTSER2	002AH
INTSR2	002CH
INTCSI2	
INTST2	002EH

### 9.3 Context Switching

When an interrupt request is generated, or when the BRKCS instruction is executed, an appropriate register bank is selected by the hardware. Then, a branch to a vector address stored in that register bank occurs. At the same time, the contents of the current program counter (PC) and program status word (PSW) are stacked in the register bank.

The branch address must be within the range of 0 to FFFFH.

Figure 9-1. Context Switching Caused by an Interrupt Request

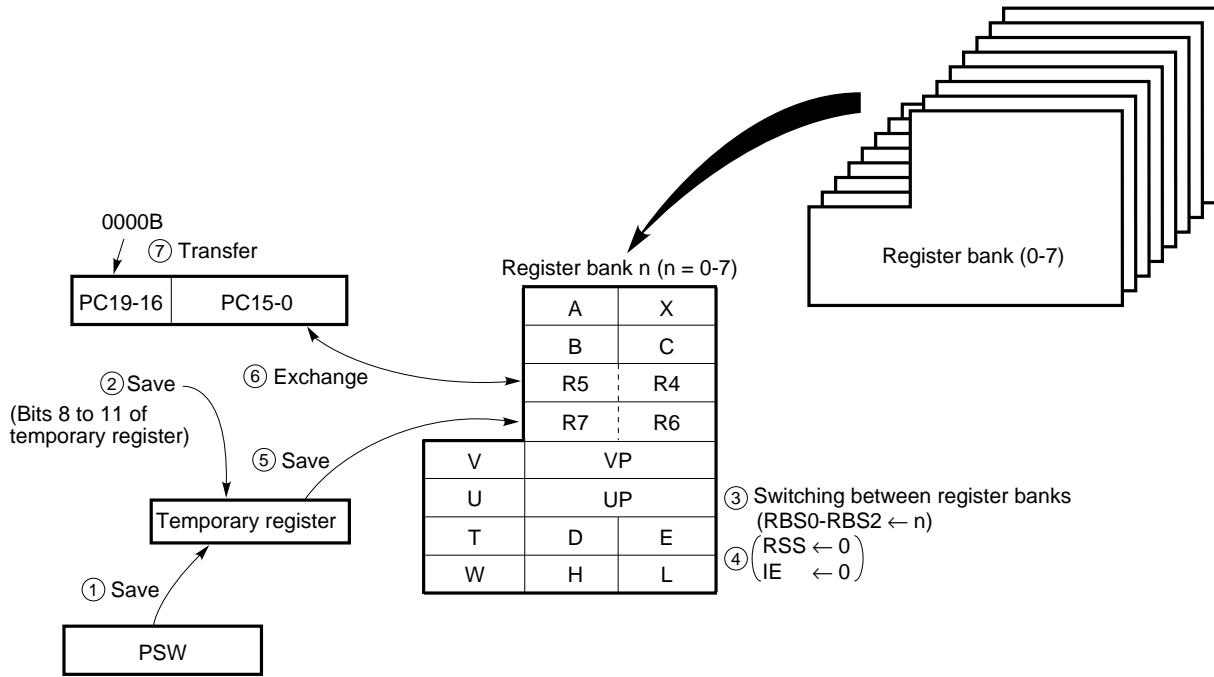

### 9.4 Macro Service

The macro service function enables data transfer between memory and special function registers (SFRs) without requiring the intervention of the CPU. The macro service controller accesses both memory and SFRs within the same transfer cycle to directly transfer data without having to perform data fetch.

Since the CPU status is neither saved nor restored, nor is data fetch performed, high-speed data transfer is possible.

Figure 9-2. Macro Service

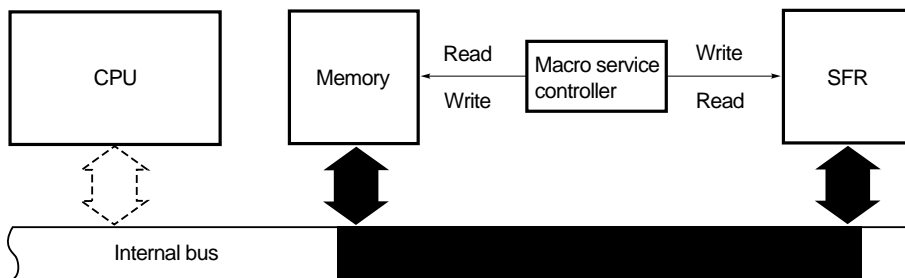

9.5 Examples of Macro Service Applications

(1) Serial interface transmission

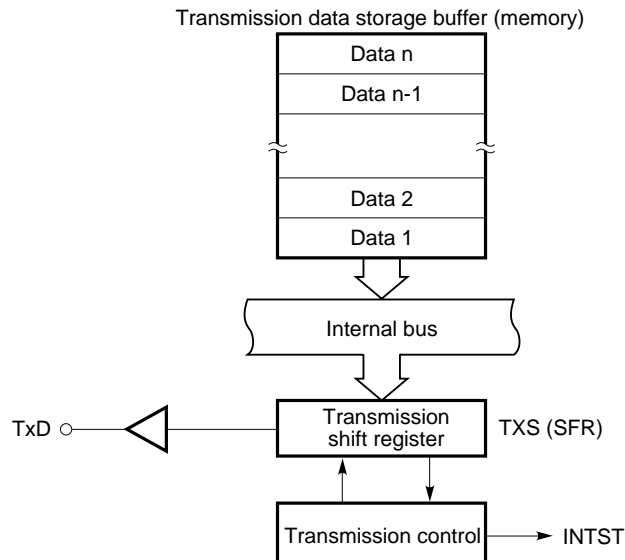

Each time macro service request (INTST) is generated, the next transmission data is transferred from memory to TXS. When data n (last byte) has been transferred to TXS (that is, once the transmission data storage buffer becomes empty), vectored interrupt request (INTST) is generated.

(2) Serial interface reception

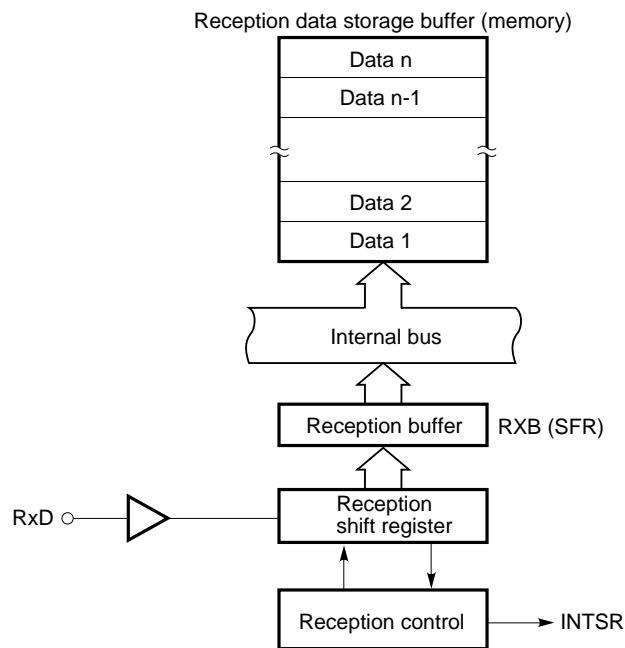

Each time macro service request (INTSR) is generated, reception data is transferred from RXB to memory. When data n (last byte) has been transferred to memory (that is, once the reception data storage buffer becomes full), vectored interrupt request (INTSR) is generated.

**(3) Real-time output port**

INTC10 and INTC11 function as the output triggers for the real-time output ports. For these triggers, the macro service can simultaneously set the next output pattern and interval. Therefore, INTC10 and INTC11 can be used to independently control two stepping motors. They can also be applied to PWM and DC motor control.

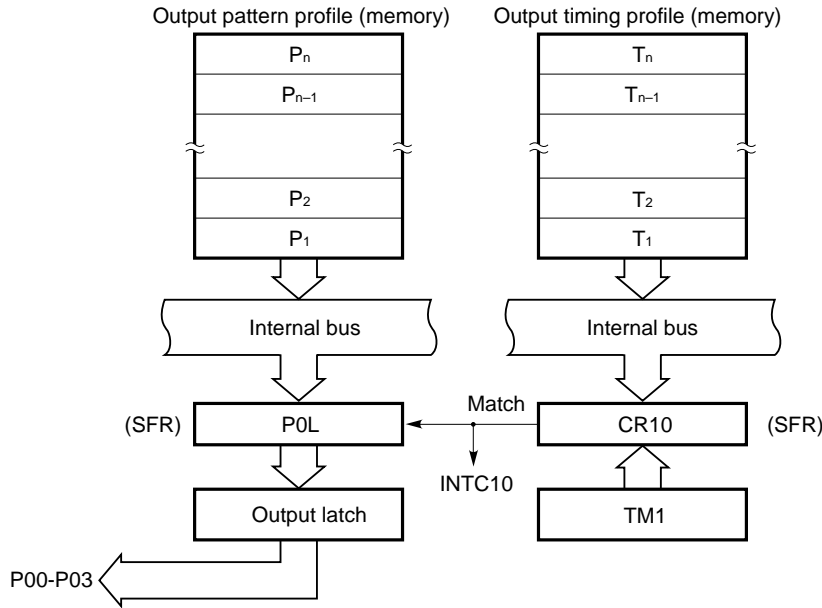

Each time macro service request (INTC10) is generated, a pattern and timing data are transferred to the buffer register (POL) and compare register (CR10), respectively. When the contents of timer register 1 (TM1) and CR10 match, another INTC10 is generated, and the POL contents are transferred to the output latch. When T<sub>n</sub> (last byte) is transferred to CR10, vectored interrupt request (INTC10) is generated. For INTC11, the same operation as that performed for INTC10 is performed.

10. LOCAL BUS INTERFACE

The local bus interface enables the connection of external memory and I/O devices (memory-mapped I/O). It supports a 1M-byte memory space. (See Figure 10-1.)

Figure 10-1. Example of Local Bus Interface

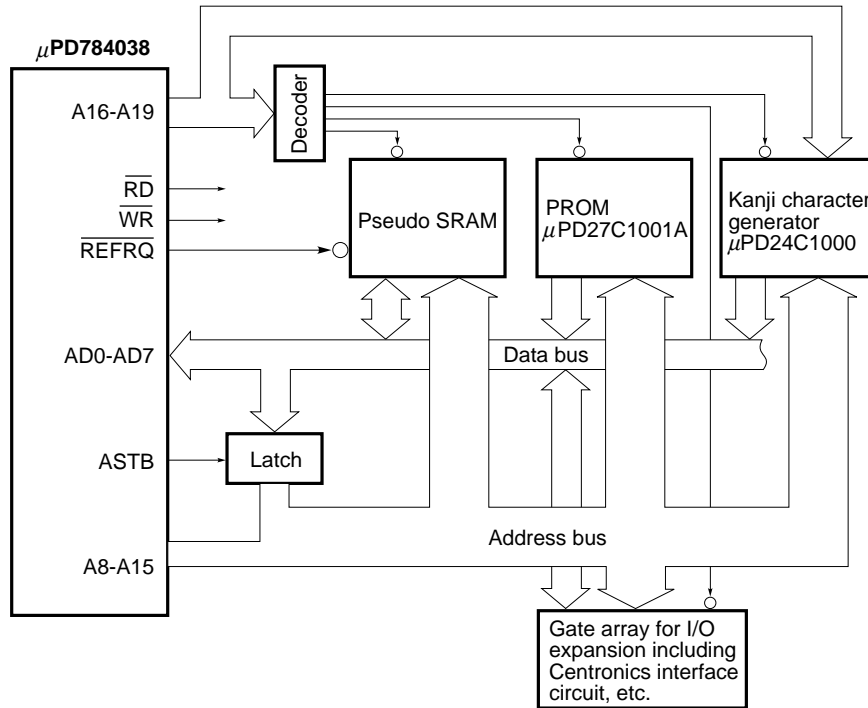

10.1 Memory Expansion

By adding external memory, program memory or data memory can be expanded, 256 bytes at a time, to approximately 1M byte (seven steps).

**10.2 Memory Space**

The 1M-byte memory space is divided into eight spaces, each having a logical address. Each of these spaces can be controlled using the programmable wait and pseudo-static RAM refresh functions.

**Figure 10-2. Memory Space**

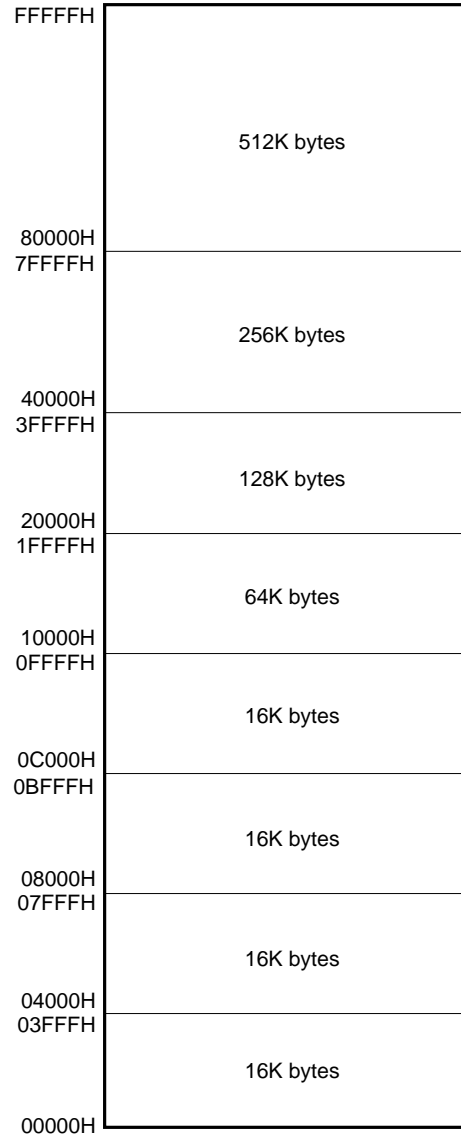

### 10.3 Programmable Wait

When the memory space is divided into eight spaces, a wait state can be separately inserted for each memory space while the  $\overline{RD}$  or  $\overline{WR}$  signal is active. This prevents the overall system efficiency from being degraded even when memory devices having different access times are connected.

In addition, an address wait function that extends the ASTB signal active period is provided to produce a longer address decode time. (This function is set for the entire space.)

### 10.4 Pseudo-Static RAM Refresh Function

Refresh is performed as follows:

- Pulse refresh : A bus cycle is inserted where a refresh pulse is output on the  $\overline{REFRQ}$  pin at regular intervals. When the memory space is divided into eight, and a specified area is being accessed, refresh pulses can also be output on the  $\overline{REFRQ}$  pin as the memory is being accessed. This can prevent the refresh cycle from suspending normal memory access.
- Power-down self-refresh : In standby mode, a low-level signal is output on the  $\overline{REFRQ}$  pin to maintain the contents of pseudo-static RAM.

### 10.5 Bus Hold Function

A bus hold function is provided to facilitate connection to devices such as a DMA controller. Suppose that a bus hold request signal (HLDRQ) is received from an external bus master. In this case, upon the completion of the bus cycle being performed, the address bus, address/data bus, ASTB,  $\overline{RD}$ , and  $\overline{WR}$  pins are placed in the high-impedance state, and the bus hold acknowledge signal (HLDAK) is made active to release the bus for the external bus master.

While the bus hold function is being used, the external wait and pseudo-static RAM refresh functions are disabled.

### 11. STANDBY FUNCTION

The standby function allows the power consumption of the chip to be reduced. The following standby modes are supported:

- HALT mode : The CPU operation clock is stopped. By occasionally inserting the HALT mode during normal operation, the overall average power consumption can be reduced.
- IDLE mode : The entire system is stopped, with the exception of the oscillator circuit. This mode consumes only very little more power than STOP mode, but normal program operation can be restored in almost as little time as that required to restore normal program operation from HALT mode.
- STOP mode : The oscillator is stopped. All operations in the chip stop, such that only leakage current flows.

These modes can be selected by software.

A macro service can be initiated in HALT mode.

**Figure 11-1. Standby Mode Status Transition**

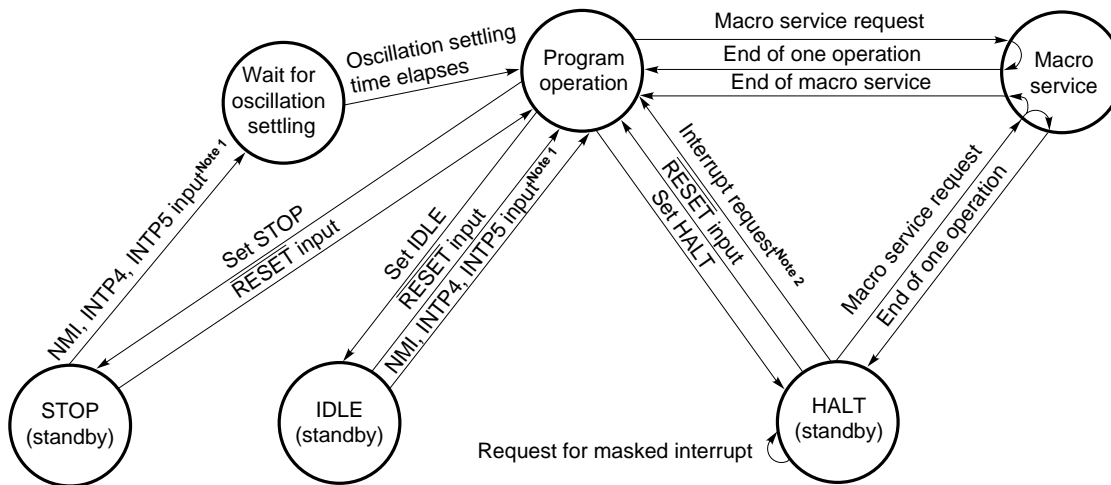

**Notes** 1. INTP4 and INTP5 are applied when not masked.

2. Only when the interrupt request is not masked

**Remark** NMI is enabled only by external input. The watchdog timer cannot be used to release one of the standby modes (STOP or IDLE mode).



## 12. RESET FUNCTION

Applying a low-level signal to the  $\overline{\text{RESET}}$  pin initializes the internal hardware (reset status).

When the  $\overline{\text{RESET}}$  input makes a low-to-high transition, the following data is loaded into the program counter (PC):

- Eight low-order bits of the PC : Contents of location at address 0000H
- Intermediate eight bits of the PC : Contents of location at address 0001H
- Four high-order bits of the PC : 0

The PC contents are used as a branch destination address. Program execution starts from that address. Therefore, a reset start can be performed from an arbitrary address.

The contents of each register can be set by software, as required.

The  $\overline{\text{RESET}}$  input circuit contains a noise eliminator to prevent malfunctions caused by noise. This noise eliminator is an analog delay sampling circuit.

**Figure 12-1. Accepting a Reset**

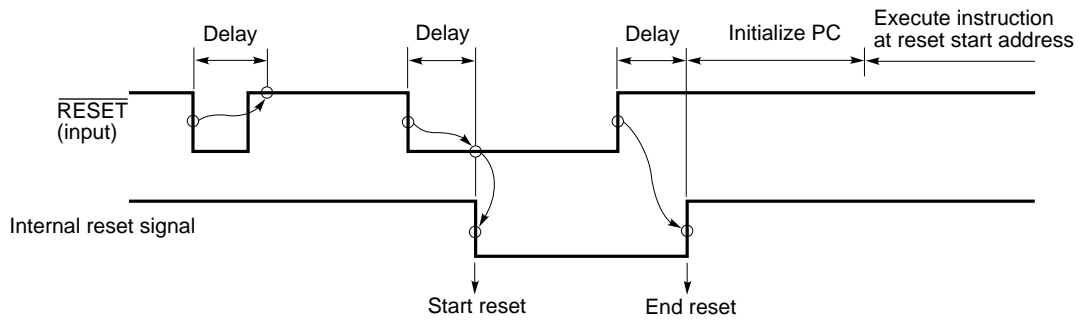

For power-on reset, the  $\overline{\text{RESET}}$  signal must be held active until the oscillation settling time (approximately 40 ms) has elapsed.

**Figure 12-2. Power-On Reset**

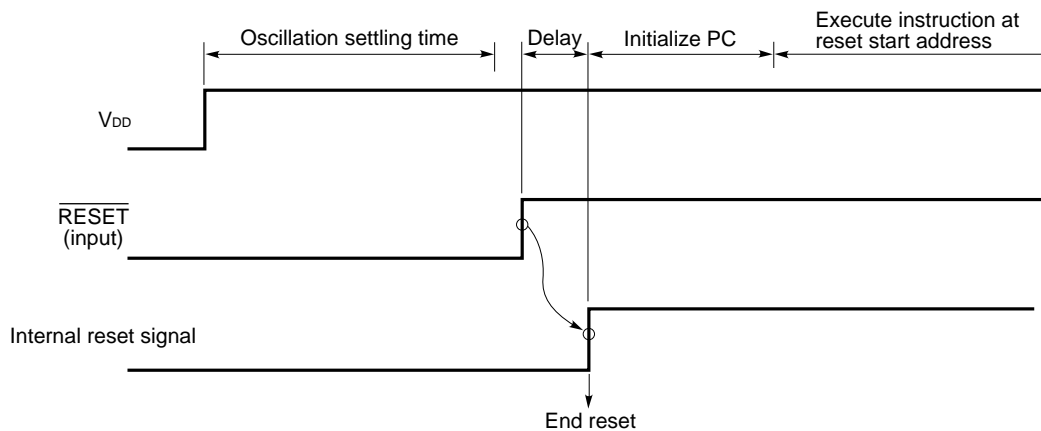

13. INSTRUCTION SET

(1) 8-bit instructions (The instructions enclosed in parentheses are implemented by a combination of operands, where A is described as r.)

MOV, XCH, ADD, ADDC, SUB, SUBC, AND, OR, XOR, CMP, MULU, DIVUW, INC, DEC, ROR, ROL, RORC, ROLC, SHR, SHL, ROR4, ROL4, DBNZ, PUSH, POP, MOVW, XCHM, CMPME, CMPMNE, CMPMNC, CMPMC, MOVBK, XCHBK, CMPBKE, CMPBKNE, CMPBKNC, CMPBKC, CHKL, CHKLA

Table 13-1. Instructions Implemented by 8-Bit Addressing

2nd operand 1st operand	#byte	A	r r'	saddr saddr'	sfr	!addr16 !!addr24	mem [saddrp] [%saddrg]	r3 PSWL PSWH	[WHL+] [WHL-]	n	NoneNote 2
A	(MOV) ADDNote 1	(MOV) (XCH) (ADD)Note 1	MOV XCH (ADD)Note 1	(MOV)Note 6 (XCH)Note 6 (ADD)Notes 1, 6	MOV (XCH) (ADD)Note 1	(MOV) (XCH) ADDNote 1	MOV XCH ADDNote 1	MOV	(MOV) (XCH) (ADD)Note 1		
r	MOV ADDNote 1	(MOV) (XCH) (ADD)Note 1	MOV XCH ADDNote 1	MOV XCH ADDNote 1	MOV XCH ADDNote 1	MOV XCH				RORNote 3	MULU DIVUW INC DEC
saddr	MOV ADDNote 1	(MOV)Note 6 (ADD)Note 1	MOV ADDNote 1	MOV XCH ADDNote 1							INC DEC DBNZ
sfr	MOV ADDNote 1	MOV (ADD)Note 1	MOV ADDNote 1								PUSH POP CHKL CHKLA
!addr16 !!addr24	MOV	(MOV) ADDNote 1	MOV								
mem [saddrp] [%saddrg]		MOV ADDNote 1									
mem3											ROR4 ROL4
r3 PSWL PSWH	MOV	MOV									
B, C											DBNZ
STBC, WDM	MOV										
[TDE+] [TDE-]		(MOV) (ADD)Note 1 MOVWNote 4							MOVBKNote 5		

- Notes**
1. ADDC, SUB, SUBC, AND, OR, XOR, and CMP are the same as ADD.
  2. There is no second operand, or the second operand is not an operand address.
  3. ROL, RORC, ROLC, SHR, and SHL are the same as ROR.
  4. XCHM, CMPME, CMPMNE, CMPMNC, and CMPMC are the same as MOVW.
  5. XCHBK, CMPBKE, CMPBKNE, CMPBKNC, and CMPBKC are the same as MOVBK.
  6. When saddr is saddr2 with this combination, an instruction with a short code exists.

(2) 16-bit instructions (The instructions enclosed in parentheses are implemented by a combination of operands, where AX is described as rp.)

MOVW, XCHW, ADDW, SUBW, CMPW, MULW, DIVUX, INCW, DECW, SHRW, SHLW, PUSH, POP, ADDWG, SUBWG, PUSHU, POPU, MOVTBLW, MACW, MACSW, SACW

Table 13-2. Instructions Implemented by 16-Bit Addressing

2nd operand 1st operand	#word	AX	rp rp'	saddrp saddrp'	sfrp	!addr16 !!addr24	mem [saddrp] [%saddrg]	[WHL+]	byte	n	None <sup>Note 2</sup>
AX	(MOVW) ADDW <sup>Note 1</sup>	(MOVW) (XCHW) (ADD) <sup>Note 1</sup>	(MOVW) (XCHW) (ADDW) <sup>Note 1</sup>	(MOVW) <sup>Note 3</sup> (XCHW) <sup>Note 3</sup> (ADDW) <sup>Notes 1,3</sup>	MOVW (XCHW) (ADDW) <sup>Note 1</sup>	(MOVW) XCHW	MOVW XCHW	(MOVW) (XCHW)			
rp	MOVW ADDW <sup>Note 1</sup>	(MOVW) (XCHW) (ADDW) <sup>Note 1</sup>	MOVW XCHW ADDW <sup>Note 1</sup>	MOVW XCHW ADDW <sup>Note 1</sup>	MOVW XCHW ADDW <sup>Note 1</sup>	MOVW				SHRW SHLW	MULW <sup>Note 4</sup> INCW DECW
saddrp	MOVW ADDW <sup>Note 1</sup>	(MOVW) <sup>Note 3</sup> (ADDW) <sup>Note 1</sup>	MOVW ADDW <sup>Note 1</sup>	MOVW XCHW ADDW <sup>Note 1</sup>							INCW DECW
sfrp	MOVW ADDW <sup>Note 1</sup>	MOVW (ADDW) <sup>Note 1</sup>	MOVW ADDW <sup>Note 1</sup>								PUSH POP
!addr16 !!addr24	MOVW	(MOVW)	MOVW						MOVTBLW		
mem [saddrp] [%saddrg]		MOVW									
PSW											PUSH POP
SP	ADDWG SUBWG										
post											PUSH POP PUSHU POPU
[TDE+]		(MOVW)						SACW			
byte											MACW MACSW

- Notes 1. SUBW and CMPW are the same as ADDW.
- 2. There is no second operand, or the second operand is not an operand address.
- 3. When saddrp is saddrp2 with this combination, an instruction with a short code exists.
- 4. MULW and DIVUX are the same as MULW.

(3) 24-bit instructions (The instructions enclosed in parentheses are implemented by a combination of operands, where WHL is described as rg.)

MOVG, ADDG, SUBG, INCG, DECG, PUSH, POP

**Table 13-3. Instructions Implemented by 24-Bit Addressing**

2nd operand 1st operand	#imm24	WHL	rg rg'	saddrg	!!addr24	mem1	[%saddrg]	SP	NoneNote
WHL	(MOVG) (ADDG) (SUBG)	(MOVG) (ADDG) (SUBG)	(MOVG) (ADDG) (SUBG)	(MOVG) ADDG SUBG	(MOVG)	MOVG	MOVG	MOVG	
rg	MOVG ADDG SUBG	(MOVG) (ADDG) (SUBG)	MOVG ADDG SUBG	MOVG	MOVG				INCG DECG PUSH POP
saddrg		(MOVG)	MOVG						
!!addr24		(MOVG)	MOVG						
mem1		MOVG							
[%saddrg]		MOVG							
SP	MOVG	MOVG							INCG DECG

**Note** There is no second operand, or the second operand is not an operand address.

(4) Bit manipulation instructions

MOV1, AND1, OR1, XOR1, SET1, CLR1, NOT1, BT, BF, BTCLR, BFSET

Table 13-4. Bit Manipulation Instructions Implemented by Addressing

2nd operand /	CY	saddr.bit sfr.bit A.bit X.bit PSWL.bit PSWH.bit mem2.bit !addr16.bit !!addr24.bit	/saddr.bit /sfr.bit /A.bit /X.bit /PSWL.bit /PSWH.bit /mem2.bit /!addr16.bit /!!addr24.bit	None <b>Note</b>
1st operand				
CY		MOV1 AND1 OR1 XOR1	AND1 OR1	NOT1 SET1 CLR1
saddr.bit sfr.bit A.bit X.bit PSWL.bit PSWH.bit mem2.bit !addr16.bit !!addr24.bit	MOV1			NOT1 SET1 CLR1 BF BT BTCLR BFSET

**Note** There is no second operand, or the second operand is not an operand address.

**(5) Call/return instructions and branch instructions**

CALL, CALLF, CALLT, BRK, RET, RETI, RETB, RETCS, RETCSB, BRKCS, BR, BNZ, BNE, BZ, BE, BNC, BNL, BC, BL, BNV, BPO, BV, BPE, BP, BN, BLT, BGE, BLE, BGT, BNH, BH, BF, BT, BTCLR, BFSET, DBNZ

**Table 13-5. Call/Return and Branch Instructions Implemented by Addressing**

Instruction address operand	\$addr20	!addr20	!addr16	!!addr20	rp	rg	[rp]	[rg]	!addr11	[addr5]	RBn	None
Basic instruction	BC <sup>Note</sup> BR	CALL BR	CALL BR RETCS RETCSB	CALL BR	CALL BR	CALL BR	CALL BR	CALL BR	CALLF	CALLF	BRKCS	BRK RET RETI RETB
Composite instruction	BF BT BTCLR BFSET DBNZ											

**Note** BNZ, BNE, BZ, BE, BNC, BNL, BL, BNV, BPO, BV, BPE, BP, BN, BLT, BGE, BLE, BGT, BNH, and BH are the same as BC.

**(6) Other instructions**

ADJBA, ADJSB, CVTBW, LOCATION, SEL, NOT, EI, DI, SWRS

14. ELECTRICAL CHARACTERISTICS

ABSOLUTE MAXIMUM RATINGS (T<sub>A</sub> = 25 °C)

Parameter	Symbol	Conditions	Rating	Unit
Supply voltage	V <sub>DD</sub>		-0.5 to +7.0	V
	AV <sub>DD</sub>		AV <sub>SS</sub> to V <sub>DD</sub> + 0.5	V
	AV <sub>SS</sub>		-0.5 to +0.5	V
Input voltage	V <sub>I</sub>		-0.5 to V <sub>DD</sub> + 0.5	V
Output voltage	V <sub>O</sub>		-0.5 to V <sub>DD</sub> + 0.5	V
Output low current	I <sub>OL</sub>	At one pin	15	mA
		Total of all output pins	100	mA
Output high current	I <sub>OH</sub>	At one pin	-10	mA
		Total of all output pins	-100	mA
A/D converter reference input voltage	AV <sub>REF1</sub>		-0.5 to V <sub>DD</sub> + 0.3	V
D/A converter reference input voltage	AV <sub>REF2</sub>		-0.5 to V <sub>DD</sub> + 0.3	V
	AV <sub>REF3</sub>		-0.5 to V <sub>DD</sub> + 0.3	V
Operating ambient temperature	T <sub>A</sub>		-40 to +85	°C
Storage temperature	T <sub>stg</sub>		-65 to +150	°C

**Caution** Absolute maximum ratings are rated values beyond which physical damage will be caused to the product; if the rated value of any of the parameters in the above table is exceeded, even momentarily, the quality of the product may deteriorate. Always use the product within its rated values.

**OPERATING CONDITIONS**

- Operating ambient temperature (T<sub>A</sub>) : -40 to +85 °C
- Rise time and fall time (t<sub>r</sub>, t<sub>f</sub>) (at pins which are not specified) : 0 to 200 μs
- Power supply voltage and clock cycle time : See **Figure 14-1**.

**Figure 14-1. Power Supply Voltage and Clock Cycle Time**

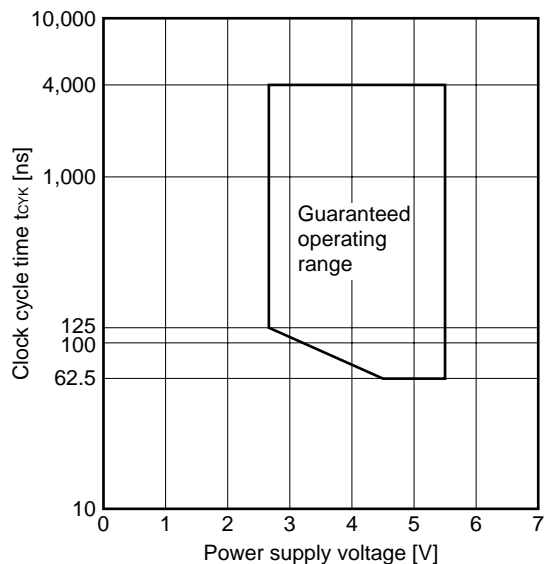

**CAPACITANCE (T<sub>A</sub> = 25 °C, V<sub>DD</sub> = V<sub>SS</sub> = 0 V)**

Parameter	Symbol	Conditions	MIN.	TYP.	MAX.	Unit
Input capacitance	C <sub>i</sub>	f = 1 MHz			10	pF
Output capacitance	C <sub>o</sub>	0 V on pins other than measured pins			10	pF
I/O capacitance	C <sub>io</sub>				10	pF



OSCILLATOR CHARACTERISTICS (T<sub>A</sub> = -40 to +85 °C, V<sub>DD</sub> = +4.5 to 5.5 V, V<sub>SS</sub> = 0 V)

Resonator	Recommended circuit	Parameter	MIN.	MAX.	Unit
Ceramic resonator or crystal		Oscillator frequency (f <sub>xx</sub> )	4	32	MHz
External clock		X1 input frequency (f <sub>x</sub> )	4	32	MHz
		X1 input rise and fall times (t <sub>xR</sub> , t <sub>xF</sub> )	0	10	ns
		X1 input high-level and low-level widths (t <sub>wxH</sub> , t <sub>wxL</sub> )	10	125	ns

**Caution** When using the system clock generator, run wires in the portion surrounded by broken lines according to the following rules to avoid effects such as stray capacitance:

- Minimize the wiring.
- Never cause the wires to cross other signal lines.
- Never cause the wires to run near a line carrying a large varying current.
- Cause the grounding point of the capacitor of the oscillator circuit to have the same potential as V<sub>SS1</sub>. Never connect the capacitor to a ground pattern carrying a large current.
- Never extract a signal from the oscillator.

**OSCILLATOR CHARACTERISTICS (T<sub>A</sub> = -40 to +85 °C, V<sub>DD</sub> = +2.7 to 5.5 V, V<sub>SS</sub> = 0 V)**

Resonator	Recommended circuit	Parameter	MIN.	MAX.	Unit
Ceramic resonator or crystal		Oscillator frequency (f <sub>xx</sub> )	4	16	MHz
External clock		X1 input frequency (f <sub>x</sub> )	4	16	MHz
		X1 input rise and fall times (t <sub>xR</sub> , t <sub>xF</sub> )	0	10	ns
		X1 input high-level and low-level widths (t <sub>wXH</sub> , t <sub>wXL</sub> )	10	125	ns

**Caution** When using the system clock generator, run wires in the portion surrounded by broken lines according to the following rules to avoid effects such as stray capacitance:

- Minimize the wiring.
- Never cause the wires to cross other signal lines.
- Never cause the wires to run near a line carrying a large varying current.
- Cause the grounding point of the capacitor of the oscillator circuit to have the same potential as V<sub>SS1</sub>. Never connect the capacitor to a ground pattern carrying a large current.
- Never extract a signal from the oscillator.

DC CHARACTERISTICS ( $T_A = -40$  to  $+85$  °C,  $V_{DD} = AV_{DD} = +2.7$  to  $5.5$  V,  $V_{SS} = AV_{SS} = 0$  V) (1/2)

Parameter	Symbol	Conditions	MIN.	TYP.	MAX.	Unit
Input low voltage	$V_{IL1}$	For pins other than those described in Notes 1, 2, 3, and 4	-0.3		$0.3V_{DD}$	V
	$V_{IL2}$	For pins described in Notes 1, 2, 3, and 4	-0.3		$0.2V_{DD}$	V
	$V_{IL3}$	$V_{DD} = +5.0$ V $\pm$ 10 % For pins described in Notes 2, 3, and 4	-0.3		+0.8	V
Input high voltage	$V_{IH1}$	For pins other than those described in Note 1	$0.7V_{DD}$		$V_{DD} + 0.3$	V
	$V_{IH2}$	For pins described in Note 1	$0.8V_{DD}$		$V_{DD} + 0.3$	V
	$V_{IH3}$	$V_{DD} = +5.0$ V $\pm$ 10 % For pins described in Notes 2, 3, and 4	2.2		$V_{DD} + 0.3$	V
Output low voltage	$V_{OL1}$	$I_{OL} = 2$ mA			0.4	V
	$V_{OL2}$	$V_{DD} = +5.0$ V $\pm$ 10 % $I_{OL} = 8$ mA For pins described in Notes 2 and 5			1.0	V
Output high voltage	$V_{OH1}$	$I_{OH} = -2$ mA	$V_{DD} - 1.0$			V
	$V_{OH2}$	$V_{DD} = +5.0$ V $\pm$ 10 % $I_{OH} = -5$ mA For pins described in Note 4	$V_{DD} - 1.4$			V
X1 input low current	$I_{IL}$	EXTC = 0 $0$ V $\leq V_1 \leq V_{IL2}$			-30	$\mu$ A
X1 input high current	$I_{IH}$	EXTC = 0 $V_{IH2} \leq V_1 \leq V_{DD}$			+30	$\mu$ A

- Notes**
1. X1, X2,  $\overline{\text{RESET}}$ , P12/ $\overline{\text{ASCK2/SCK2}}$ , P20/ $\overline{\text{NMI}}$ , P21/ $\overline{\text{INTP0}}$ , P22/ $\overline{\text{INTP1}}$ , P23/ $\overline{\text{INTP2/CI}}$ , P24/ $\overline{\text{INTP3}}$ , P25/ $\overline{\text{INTP4/ASCK/SCK1}}$ , P26/ $\overline{\text{INTP5}}$ , P27/ $\overline{\text{SI0}}$ , P32/ $\overline{\text{SCK0/SCL}}$ , P33/ $\overline{\text{SO0/SDA}}$ , TEST
  2. P40/ $\overline{\text{AD0-P47/AD7}}$ , P50/ $\overline{\text{A8-P57/A15}}$
  3. P60/ $\overline{\text{A16-P63/A19}}$ , P64/ $\overline{\text{RD}}$ , P65/ $\overline{\text{WR}}$ , P66/ $\overline{\text{WAIT/HLDRQ}}$ , P67/ $\overline{\text{REFRQ/HLDAK}}$
  4. P00-P07
  5. P10-P17

DC CHARACTERISTICS (T<sub>A</sub> = -40 to +85 °C, V<sub>DD</sub> = AV<sub>DD</sub> = +2.7 to 5.5 V, V<sub>SS</sub> = AV<sub>SS</sub> = 0 V) (2/2)

Parameter	Symbol	Conditions	MIN.	TYP.	MAX.	Unit
Input leakage current	I <sub>LI</sub>	0 V ≤ V <sub>I</sub> ≤ V <sub>DD</sub> For pins other than X1 when EXTC = 0			±10	μA
Output leakage current	I <sub>LO</sub>	0 V ≤ V <sub>O</sub> ≤ V <sub>DD</sub>			±10	μA
V <sub>DD</sub> supply current	I <sub>DD1</sub>	Operation mode f <sub>XX</sub> = 32 MHz V <sub>DD</sub> = +5.0 V ± 10 %		25	45	mA
				12	25	mA
	I <sub>DD2</sub>	HALT mode f <sub>XX</sub> = 32 MHz V <sub>DD</sub> = +5.0 V ± 10 %		13	26	mA
				8	12	mA
	I <sub>DD3</sub>	IDLE mode (EXTC = 0) f <sub>XX</sub> = 32 MHz V <sub>DD</sub> = +5.0 V ± 10 %			12	mA
					8	mA
Pull-up resistor	R <sub>L</sub>	V <sub>I</sub> = 0 V	15		80	kΩ

AC CHARACTERISTICS (T<sub>A</sub> = -40 to +85 °C, V<sub>DD</sub> = AV<sub>DD</sub> = +2.7 to 5.5 V, V<sub>SS</sub> = AV<sub>SS</sub> = 0 V)

(1) Read/write operation (1/2)

Parameter	Symbol	Conditions	MIN.	MAX.	Unit
Address setup time	t <sub>SAST</sub>	V <sub>DD</sub> = +5.0 V ± 10 %	(0.5 + a) T - 15		ns
			(0.5 + a) T - 31		ns
ASTB high-level width	t <sub>WSTH</sub>	V <sub>DD</sub> = +5.0 V ± 10 %	(0.5 + a) T - 17		ns
			(0.5 + a) T - 40		ns
Address hold time (to ASTB↓)	t <sub>HSTLA</sub>	V <sub>DD</sub> = +5.0 V ± 10 %	0.5T - 24		ns
			0.5T - 34		ns
Address hold time (to $\overline{RD}\uparrow$ )	t <sub>HRA</sub>		0.5T - 14		ns
Delay from address to $\overline{RD}\downarrow$	t <sub>DAR</sub>	V <sub>DD</sub> = +5.0 V ± 10 %	(1 + a) T - 9		ns
			(1 + a) T - 15		ns
Address float time (to $\overline{RD}\downarrow$ )	t <sub>FRA</sub>			0	ns
Delay from address to data input	t <sub>DAID</sub>	V <sub>DD</sub> = +5.0 V ± 10 %		(2.5 + a + n) T - 37	ns
				(2.5 + a + n) T - 52	ns
Delay from ASTB↓ to data input	t <sub>DSTID</sub>	V <sub>DD</sub> = +5.0 V ± 10 %		(2 + n) T - 40	ns
				(2 + n) T - 60	ns
Delay from $\overline{RD}\downarrow$ to data input	t <sub>DRID</sub>	V <sub>DD</sub> = +5.0 V ± 10 %		(1.5 + n) T - 50	ns
				(1.5 + n) T - 70	ns
Delay from ASTB↓ to $\overline{RD}\downarrow$	t <sub>DSTR</sub>		0.5T - 9		ns
Data hold time (to $\overline{RD}\uparrow$ )	t <sub>HRID</sub>		0		ns
Delay from $\overline{RD}\uparrow$ to address active	t <sub>DRA</sub>	After program is read	V <sub>DD</sub> = +5.0 V ± 10 %	0.5T - 8	ns
				0.5T - 12	ns
		After data is read	V <sub>DD</sub> = +5.0 V ± 10 %	1.5T - 8	ns
				1.5T - 12	ns
Delay from $\overline{RD}\uparrow$ to ASTB↑	t <sub>DRST</sub>		0.5T - 17		ns
$\overline{RD}$ low-level width	t <sub>WRL</sub>	V <sub>DD</sub> = +5.0 V ± 10 %	(1.5 + n) T - 30		ns
			(1.5 + n) T - 40		ns
Address hold time (to $\overline{WR}\uparrow$ )	t <sub>HWA</sub>		0.5T - 14		ns
Delay from address to $\overline{WR}\downarrow$	t <sub>DAW</sub>	V <sub>DD</sub> = +5.0 V ± 10 %	(1 + a) T - 5		ns
			(1 + a) T - 15		ns
Delay from ASTB↓ to data output	t <sub>DSTOD</sub>	V <sub>DD</sub> = +5.0 V ± 10 %		0.5T + 19	ns
				0.5T + 35	ns
Delay from $\overline{WR}\downarrow$ to data output	t <sub>DWOD</sub>			0.5T - 11	ns
Delay from ASTB↓ to $\overline{WR}\downarrow$	t <sub>DSTW</sub>		0.5T - 9		ns

**Remarks** T: T<sub>CYK</sub> (system clock cycle time)  
a: 1 (during address wait), otherwise, 0  
n: Number of wait states (n ≥ 0)

(1) Read/write operation (2/2)

Parameter	Symbol	Conditions	MIN.	MAX.	Unit
Data setup time (to $\overline{WR}\uparrow$ )	ts <sub>ODW</sub>	V <sub>DD</sub> = +5.0 V ± 10 %	(1.5 + n) T - 30		ns
			(1.5 + n) T - 40		ns
Data hold time (to $\overline{WR}\uparrow$ ) <sup>Note</sup>	t <sub>HWOD</sub>	V <sub>DD</sub> = +5.0 V ± 10 %	0.5T - 5		ns
			0.5T - 25		ns
Delay from $\overline{WR}\uparrow$ to ASTB $\uparrow$	t <sub>DWST</sub>		0.5T - 12		ns
$\overline{WR}$ low-level width	t <sub>WWL</sub>	V <sub>DD</sub> = +5.0 V ± 10 %	(1.5 + n) T - 30		ns
			(1.5 + n) T - 40		ns

**Note** The hold time includes the time during which V<sub>OH1</sub> and V<sub>OL1</sub> are held under the load conditions of C<sub>L</sub> = 50 pF and R<sub>L</sub> = 4.7 kΩ.

**Remarks** T: T<sub>CYK</sub> (system clock cycle time)  
 n: Number of wait states (n ≥ 0)

(2) Bus hold timing

Parameter	Symbol	Conditions	MIN.	MAX.	Unit
Delay from HLDRQ $\uparrow$ to float	t <sub>FHQC</sub>			(6 + a + n) T + 50	ns
Delay from HLDRQ $\uparrow$ to HLDAK $\uparrow$	t <sub>DHQHHAH</sub>	V <sub>DD</sub> = +5.0 V ± 10 %		(7 + a + n) T + 30	ns
				(7 + a + n) T + 40	ns
Delay from float to HLDAK $\uparrow$	t <sub>DCFHA</sub>			1T + 30	ns
Delay from HLDRQ $\downarrow$ to HLDAK $\downarrow$	t <sub>DHQLHAL</sub>	V <sub>DD</sub> = +5.0 V ± 10 %		2T + 40	ns
				2T + 60	ns
Delay from HLDAK $\downarrow$ to active	t <sub>DHAC</sub>	V <sub>DD</sub> = +5.0 V ± 10 %	1T - 20		ns
			1T - 30		ns

**Remarks** T: T<sub>CYK</sub> (system clock cycle time)  
 a: 1 (during address wait), otherwise, 0  
 n: Number of wait states (n ≥ 0)

(3) External wait timing

Parameter	Symbol	Conditions	MIN.	MAX.	Unit
Delay from address to $\overline{\text{WAIT}}\downarrow$ input	$t_{\text{DAWT}}$	$V_{\text{DD}} = +5.0 \text{ V} \pm 10 \%$		$(2 + a) T - 40$	ns
				$(2 + a) T - 60$	ns
Delay from $\text{ASTB}\downarrow$ to $\overline{\text{WAIT}}\downarrow$ input	$t_{\text{DSTWT}}$	$V_{\text{DD}} = +5.0 \text{ V} \pm 10 \%$		$1.5T - 40$	ns
				$1.5T - 60$	ns
Hold time from $\text{ASTB}\downarrow$ to $\overline{\text{WAIT}}$	$t_{\text{HSTWTH}}$	$V_{\text{DD}} = +5.0 \text{ V} \pm 10 \%$	$(0.5 + n) T + 5$		ns
			$(0.5 + n) T + 10$		ns
Delay from $\text{ASTB}\downarrow$ to $\overline{\text{WAIT}}\uparrow$	$t_{\text{DSTWTH}}$	$V_{\text{DD}} = +5.0 \text{ V} \pm 10 \%$		$(1.5 + n) T - 40$	ns
				$(1.5 + n) T - 60$	ns
Delay from $\overline{\text{RD}}\downarrow$ to $\overline{\text{WAIT}}\downarrow$ input	$t_{\text{DRWTL}}$	$V_{\text{DD}} = +5.0 \text{ V} \pm 10 \%$		$T - 50$	ns
				$T - 70$	ns
Hold time from $\overline{\text{RD}}\downarrow$ to $\overline{\text{WAIT}}\downarrow$	$t_{\text{HRWT}}$	$V_{\text{DD}} = +5.0 \text{ V} \pm 10 \%$	$nT + 5$		ns
			$nT + 10$		ns
Delay from $\overline{\text{RD}}\downarrow$ to $\overline{\text{WAIT}}\uparrow$	$t_{\text{DRWTH}}$	$V_{\text{DD}} = +5.0 \text{ V} \pm 10 \%$		$(1 + n) T - 40$	ns
				$(1 + n) T - 60$	ns
Delay from $\overline{\text{WAIT}}\uparrow$ to data input	$t_{\text{DWTID}}$	$V_{\text{DD}} = +5.0 \text{ V} \pm 10 \%$		$0.5T - 5$	ns
				$0.5T - 10$	ns
Delay from $\overline{\text{WAIT}}\uparrow$ to $\overline{\text{WR}}\uparrow$	$t_{\text{DWTW}}$		$0.5T$		ns
Delay from $\overline{\text{WAIT}}\uparrow$ to $\overline{\text{RD}}\uparrow$	$t_{\text{DWTR}}$		$0.5T$		ns
Delay from $\overline{\text{WR}}\downarrow$ to $\overline{\text{WAIT}}\downarrow$ input	$t_{\text{DWWTL}}$	$V_{\text{DD}} = +5.0 \text{ V} \pm 10 \%$		$T - 50$	ns
				$T - 75$	ns
Hold time from $\overline{\text{WR}}\downarrow$ to $\overline{\text{WAIT}}$	$t_{\text{HWWT}}$	$V_{\text{DD}} = +5.0 \text{ V} \pm 10 \%$	$nT + 5$		ns
			$nT + 10$		ns
Delay from $\overline{\text{WR}}\downarrow$ to $\overline{\text{WAIT}}\uparrow$	$t_{\text{DWWTH}}$	$V_{\text{DD}} = +5.0 \text{ V} \pm 10 \%$		$(1 + n) T - 40$	ns
				$(1 + n) T - 70$	ns

**Remarks** T:  $T_{\text{CYK}}$  (system clock cycle time)  
a: 1 (during address wait), otherwise, 0  
n: Number of wait states ( $n \geq 0$ )

(4) Refresh timing

Parameter	Symbol	Conditions	MIN.	MAX.	Unit
Random read/write cycle time	$t_{\text{RC}}$		$3T$		ns
REFRQ low-level pulse width	$t_{\text{WRFQL}}$	$V_{\text{DD}} = +5.0 \text{ V} \pm 10 \%$	$1.5T - 25$		ns
			$1.5T - 30$		ns
Delay from $\text{ASTB}\downarrow$ to $\overline{\text{REFRQ}}$	$t_{\text{DSTRFQ}}$		$0.5T - 9$		ns
Delay from $\overline{\text{RD}}\uparrow$ to $\overline{\text{REFRQ}}$	$t_{\text{DRRFQ}}$		$1.5T - 9$		ns
Delay from $\overline{\text{WR}}\uparrow$ to $\overline{\text{REFRQ}}$	$t_{\text{DWRFQ}}$		$1.5T - 9$		ns
Delay from $\overline{\text{REFRQ}}\uparrow$ to $\text{ASTB}$	$t_{\text{DRFQST}}$		$0.5T - 15$		ns
REFRQ high-level pulse width	$t_{\text{WRFQH}}$	$V_{\text{DD}} = +5.0 \text{ V} \pm 10 \%$	$1.5T - 25$		ns
			$1.5T - 30$		ns

**Remark** T:  $T_{\text{CYK}}$  (system clock cycle time)

**SERIAL OPERATION (T<sub>A</sub> = -40 to +85 °C, V<sub>DD</sub> = +2.7 to 5.5 V, AV<sub>SS</sub> = V<sub>SS</sub> = 0 V)**

(1) CSI

Parameter	Symbol	Conditions		MIN.	MAX.	Unit
Serial clock cycle time ( $\overline{\text{SCK0}}$ )	tcYSK0	Input	External clock When $\overline{\text{SCK0}}$ and S00 are CMOS I/O	10/f <sub>xx</sub> + 380		ns
		Output		T		μs
Serial clock low-level width ( $\overline{\text{SCK0}}$ )	twSKL0	Input	External clock When $\overline{\text{SCK0}}$ and S00 are CMOS I/O	5/f <sub>xx</sub> + 150		ns
		Output		0.5T - 40		μs
Serial clock high-level width ( $\overline{\text{SCK0}}$ )	twSKH0	Input	External clock When $\overline{\text{SCK0}}$ and S00 are CMOS I/O	5/f <sub>xx</sub> + 150		ns
		Output		0.5T - 40		μs
SIO setup time (to $\overline{\text{SCK0}}\uparrow$ )	tSSSK0			40		ns
SIO hold time (to $\overline{\text{SCK0}}\uparrow$ )	tHSSK0			5/f <sub>xx</sub> + 40		ns
S00 output delay time (to $\overline{\text{SCK0}}\downarrow$ )	tDSBSK1	CMOS push-pull output (3-wire serial I/O mode)		0	5/f <sub>xx</sub> + 150	ns
	tDSBSK2	Open-drain output (2-wire serial I/O mode), R <sub>L</sub> = 1 kΩ		0	5/f <sub>xx</sub> + 400	ns

- Remarks**
1. The values in this table are those when C<sub>L</sub> is 100 pF.
  2. T : Serial clock cycle set by software. The minimum value is 16/f<sub>xx</sub>.
  3. f<sub>xx</sub>: Oscillator frequency



(2) IOE1, IOE2

Parameter	Symbol	Conditions		MIN.	MAX.	Unit
Serial clock cycle time ( $\overline{SCK1}$ , $\overline{SCK2}$ )	$t_{CYSK1}$	Input	$V_{DD} = +5.0\text{ V} \pm 10\%$	250		ns
				500		ns
		Output	Internal, divided by 16	T		ns
Serial clock low-level width ( $\overline{SCK1}$ , $\overline{SCK2}$ )	$t_{WSKL1}$	Input	$V_{DD} = +5.0\text{ V} \pm 10\%$	85		ns
				210		ns
		Output	Internal, divided by 16	0.5T - 40		ns
Serial clock high-level width ( $\overline{SCK1}$ , $\overline{SCK2}$ )	$t_{WSKH1}$	Input	$V_{DD} = +5.0\text{ V} \pm 10\%$	85		ns
				210		ns
		Output	Internal, divided by 16	0.5T - 40		ns
Setup time for SI1 and SI2 (to $\overline{SCK1}$ , $\overline{SCK2}\uparrow$ )	$t_{SSK1}$			40		ns
Hold time for SI1 and SI2 (to $\overline{SCK1}$ , $\overline{SCK2}\uparrow$ )	$t_{HSSK1}$			40		ns
Output delay time for SO1 and SO2 (to $\overline{SCK1}$ , $\overline{SCK2}\downarrow$ )	$t_{DSOSK}$			0	50	ns
Output hold time for SO1 and SO2 (to $\overline{SCK1}$ , $\overline{SCK2}\uparrow$ )	$t_{HSOSK}$	When data is transferred		$0.5t_{CYSK1} - 40$		ns

**Remarks 1.** The values in this table are those when  $C_L$  is 100 pF.

**2.** T: Serial clock cycle set by software. The minimum value is  $16/f_{xx}$ .

(3) UART, UART2

Parameter	Symbol	Conditions	MIN.	MAX.	Unit
ASCK clock input cycle time	$t_{CYASK}$	$V_{DD} = +5.0\text{ V} \pm 10\%$	125		ns
			250		ns
ASCK clock low-level width	$t_{WASKL}$	$V_{DD} = +5.0\text{ V} \pm 10\%$	52.5		ns
			85		ns
ASCK clock high-level width	$t_{WASKH}$	$V_{DD} = +5.0\text{ V} \pm 10\%$	52.5		ns
			85		ns

**CLOCK OUTPUT OPERATION**

Parameter	Symbol	Conditions	MIN.	MAX.	Unit
CLKOUT cycle time	t <sub>CYCL</sub>		nT		ns
CLKOUT low-level width	t <sub>CLL</sub>	V <sub>DD</sub> = +5.0 V ± 10 %	0.5t <sub>CYCL</sub> - 10		ns
			0.5t <sub>CYCL</sub> - 20		ns
CLKOUT high-level width	t <sub>CLH</sub>	V <sub>DD</sub> = +5.0 V ± 10 %	0.5t <sub>CYCL</sub> - 10		ns
			0.5t <sub>CYCL</sub> - 20		ns
CLKOUT rise time	t <sub>CLR</sub>	V <sub>DD</sub> = +5.0 V ± 10 %		10	ns
				20	ns
CLKOUT fall time	t <sub>CLF</sub>	V <sub>DD</sub> = +5.0 V ± 10 %		10	ns
				20	ns

**Remarks** n: Divided frequency ratio set by software in the CPU (n = 1, 2, 4, 8, 16)  
 T: T<sub>CYK</sub> (system clock cycle time)

**OTHER OPERATIONS**

Parameter	Symbol	Conditions	MIN.	MAX.	Unit
NMI low-level width	t <sub>WNIL</sub>		10		μs
NMI high-level width	t <sub>WNIH</sub>		10		μs
★ INTP0 low-level width	t <sub>WIT0L</sub>		4t <sub>CYSMP</sub>		ns
★ INTP0 high-level width	t <sub>WIT0H</sub>		4t <sub>CYSMP</sub>		ns
★ Low-level width for INTP1-INTP3 and CI	t <sub>WIT1L</sub>		4t <sub>CYCPU</sub>		ns
★ High-level width for INTP1-INTP3 and CI	t <sub>WIT1H</sub>		4t <sub>CYCPU</sub>		ns
Low-level width for INTP4 and INTP5	t <sub>WIT2L</sub>		10		μs
High-level width for INTP4 and INTP5	t <sub>WIT2H</sub>		10		μs
RESET low-level width	t <sub>WRSL</sub>		10		μs
RESET high-level width	t <sub>WRSH</sub>		10		μs

**Remarks** t<sub>CYSMP</sub>: Sampling clock set by software  
 t<sub>CYCPU</sub>: CPU operation clock set by software in the CPU

**A/D CONVERTER CHARACTERISTICS (T<sub>A</sub> = -40 to +85 °C, V<sub>DD</sub> = AV<sub>DD</sub> = AV<sub>REF1</sub> = +2.7 to 5.5 V, V<sub>SS</sub> = AV<sub>SS</sub> = 0 V)**

Parameter	Symbol	Conditions	MIN.	TYP.	MAX.	Unit
Resolution			8			bit
Total error <sup>Note</sup>					1.0	%
Linearity calibration <sup>Note</sup>					0.8	%
Quantization error					±1/2	LSB
Conversion time	t <sub>CONV</sub>	FR = 1	120			t <sub>CYK</sub>
		FR = 0	180			t <sub>CYK</sub>
Sampling time	t <sub>SAMP</sub>	FR = 1	24			t <sub>CYK</sub>
		FR = 0	36			t <sub>CYK</sub>
Analog input voltage	V <sub>IAN</sub>		-0.3		AV <sub>REF1</sub> + 0.3	V
Analog input impedance	R <sub>AN</sub>			1,000		MΩ
AV <sub>REF1</sub> current	AI <sub>REF1</sub>			0.5	1.5	mA
AV <sub>DD</sub> supply current	AI <sub>DD1</sub>	f <sub>XX</sub> = 32 MHz, CS = 1		2.0	5.0	mA
	AI <sub>DD2</sub>	STOP mode, CS = 0		1.0	20	μA

**Note** Quantization error is not included. This parameter is indicated as the ratio to the full-scale value.

**Remark** t<sub>CYK</sub>: System clock cycle time

D/A CONVERTER CHARACTERISTICS (T<sub>A</sub> = -40 to +85 °C, V<sub>DD</sub> = AV<sub>DD</sub> = +2.7 to 5.5 V, V<sub>SS</sub> = AV<sub>SS</sub> = 0 V)

Parameter	Symbol	Conditions	MIN.	TYP.	MAX.	Unit	
Resolution			8			bit	
Total error		Load conditions: 4 MΩ, 30 pF	V <sub>DD</sub> = AV <sub>DD</sub> = AV <sub>REF2</sub> = +2.7 to 5.5 V AV <sub>REF3</sub> = 0 V			0.6	%
			V <sub>DD</sub> = AV <sub>DD</sub> = +2.7 to 5.5 V AV <sub>REF2</sub> = 0.75V <sub>DD</sub> AV <sub>REF3</sub> = 0.25V <sub>DD</sub>			0.8	%
		Load conditions: 2 MΩ, 30 pF	V <sub>DD</sub> = AV <sub>DD</sub> = AV <sub>REF2</sub> = +2.7 to 5.5 V AV <sub>REF3</sub> = 0 V			0.8	%
			V <sub>DD</sub> = AV <sub>DD</sub> = +2.7 to 5.5 V AV <sub>REF2</sub> = 0.75V <sub>DD</sub> AV <sub>REF3</sub> = 0.25V <sub>DD</sub>			1.0	%
Settling time		Load conditions: 2 MΩ, 30 pF			10	μs	
Output resistance	R <sub>O</sub>	DACS0, 1 = 55 H		10		kΩ	
Analog reference voltage	AV <sub>REF2</sub>		0.75V <sub>DD</sub>		V <sub>DD</sub>	V	
	AV <sub>REF3</sub>		0		0.25V <sub>DD</sub>	V	
Resistance of AV <sub>REF2</sub> and AV <sub>REF3</sub>	R <sub>AIREF</sub>	DACS0, 1 = 55 H	4	8		kΩ	
Reference power supply input current	AI <sub>REF2</sub>		0		5	mA	
	AI <sub>REF3</sub>		-5		0	mA	

**DATA RETENTION CHARACTERISTICS (T<sub>A</sub> = -40 to +85 °C)**

Parameter	Symbol	Conditions	MIN.	TYP.	MAX.	Unit
Data retention voltage	V <sub>DDDR</sub>	STOP mode	2.5		5.5	V
Data retention current	I <sub>DDDR</sub>	V <sub>DDDR</sub> = +2.7 to 5.5 V		10	50	μA
		V <sub>DDDR</sub> = +2.5 V		2	10	μA
V <sub>DD</sub> rise time	t <sub>RVD</sub>		200			μs
V <sub>DD</sub> fall time	t <sub>FVD</sub>		200			μs
V <sub>DD</sub> hold time (to STOP mode setting)	t <sub>HVD</sub>		0			ms
STOP clear signal input time	t <sub>DREL</sub>		0			ms
Oscillation settling time	t <sub>WAIT</sub>	Crystal	30			ms
		Ceramic resonator	5			ms
Input low voltage	V <sub>IL</sub>	Specific pins <sup>Note</sup>	0		0.1V <sub>DDDR</sub>	V
Input high voltage	V <sub>IH</sub>		0.9V <sub>DDDR</sub>		V <sub>DDDR</sub>	V

**Note**  $\overline{\text{RESET}}$ , P20/NMI, P21/INTP0, P22/INTP1, P23/INTP2/Ci, P24/INTP3, P25/INTP4/ASCK/ $\overline{\text{SCK1}}$ , P26/INTP5, P27/SIO, P32/ $\overline{\text{SCK0}}$ /SCL, and P33/SO0/SDA pins

**AC TIMING TEST POINTS**

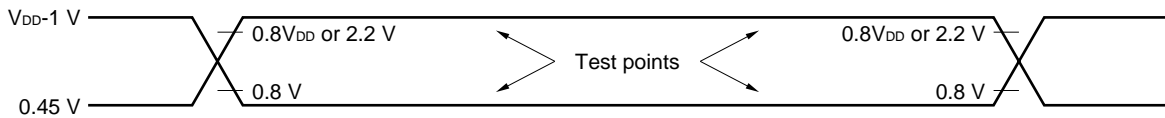

TIMING WAVEFORM

(1) Read operation

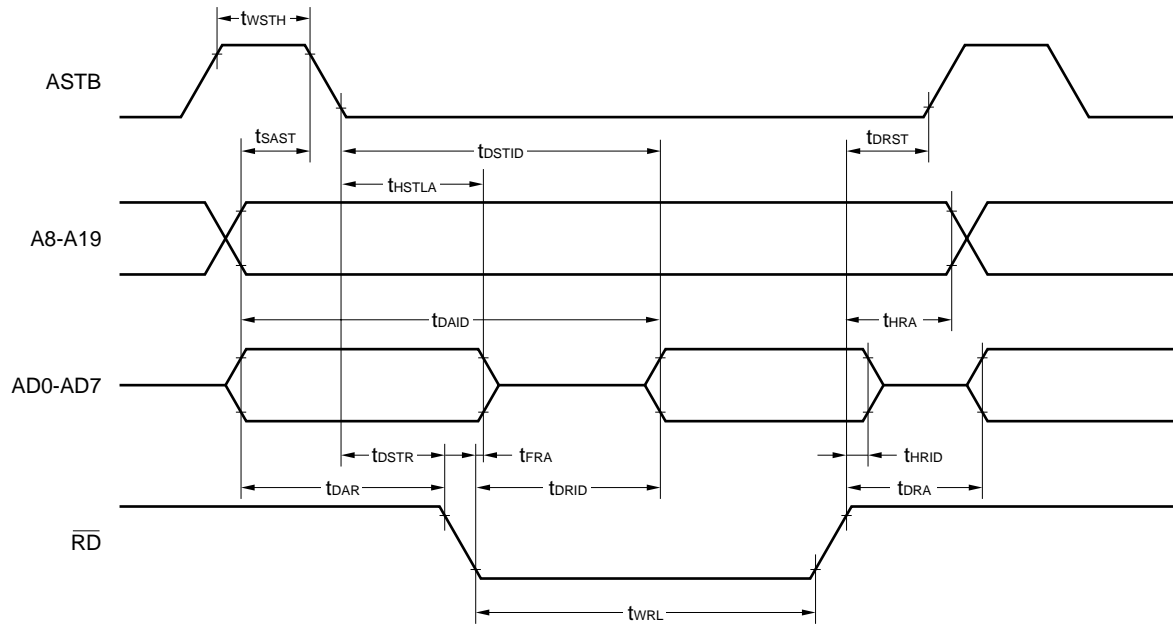

(2) Write operation

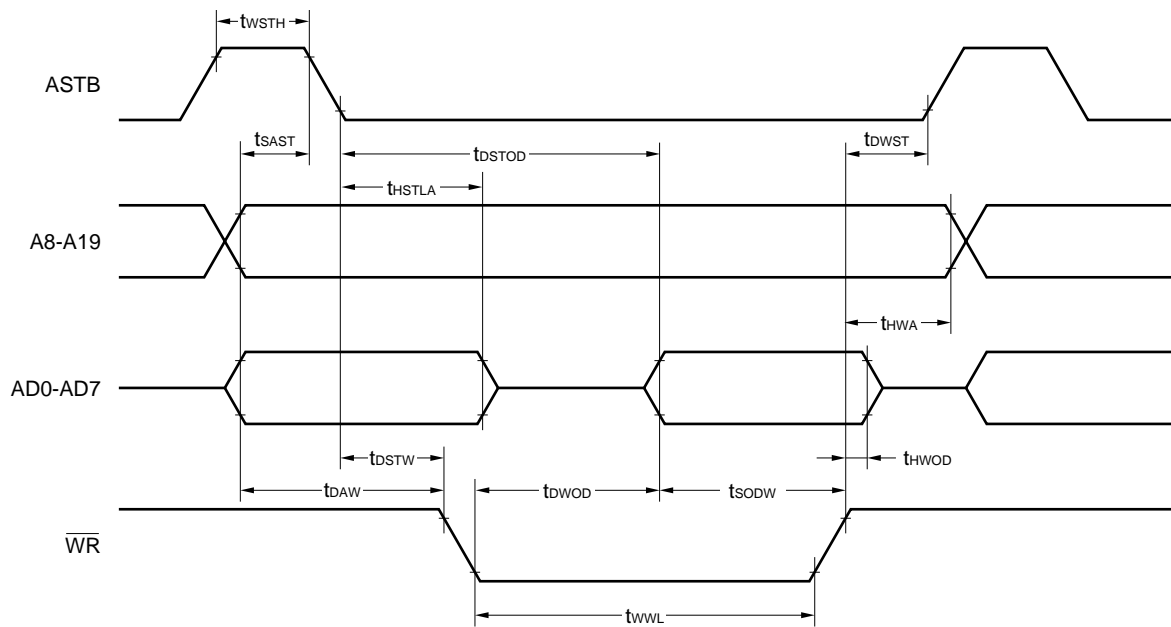

★

**HOLD TIMING**

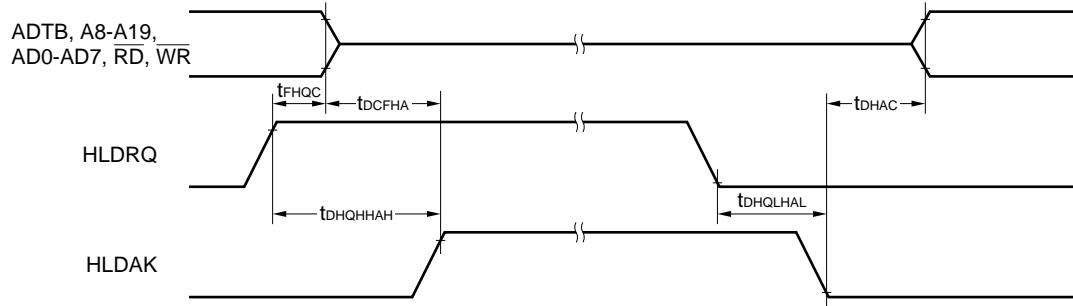

**EXTERNAL WAIT SIGNAL INPUT TIMING**

(1) Read operation

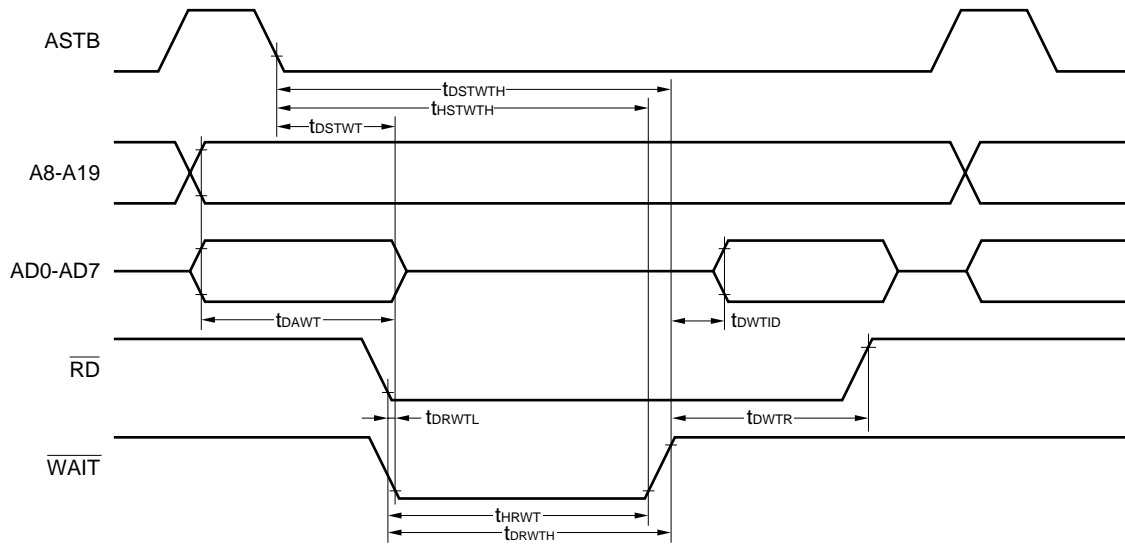

(2) Write operation

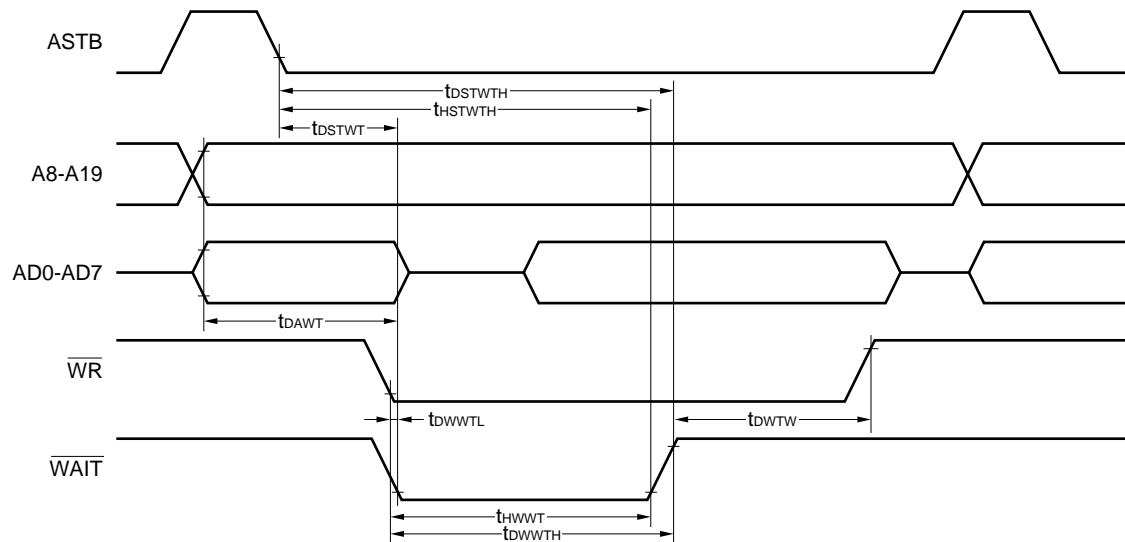

REFRESH TIMING WAVEFORM

(1) Random read/write cycle

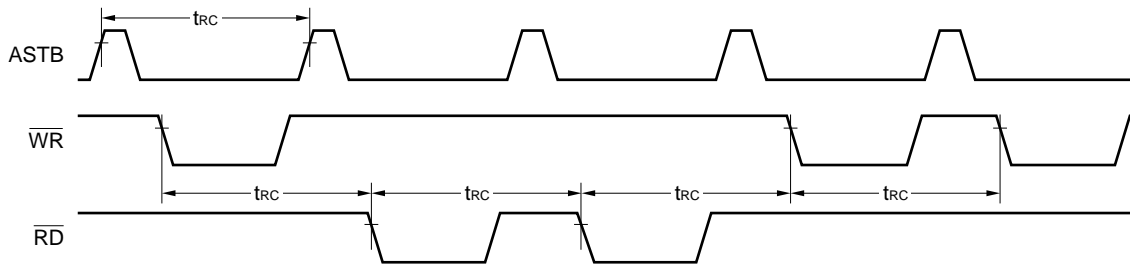

(2) When refresh memory is accessed for a read and write at the same time

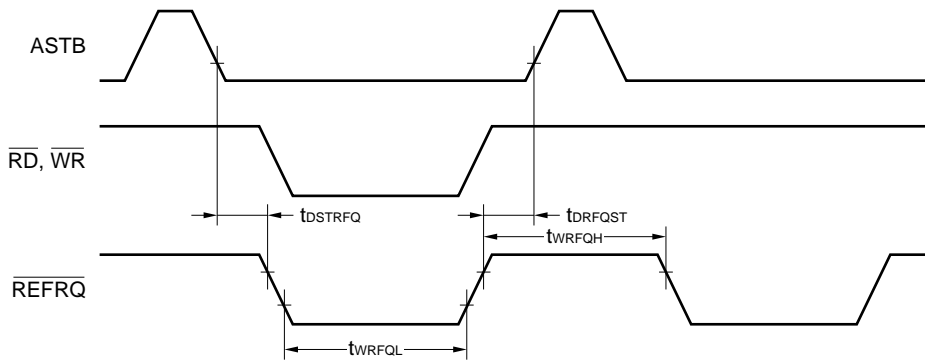

(3) Refresh after a read

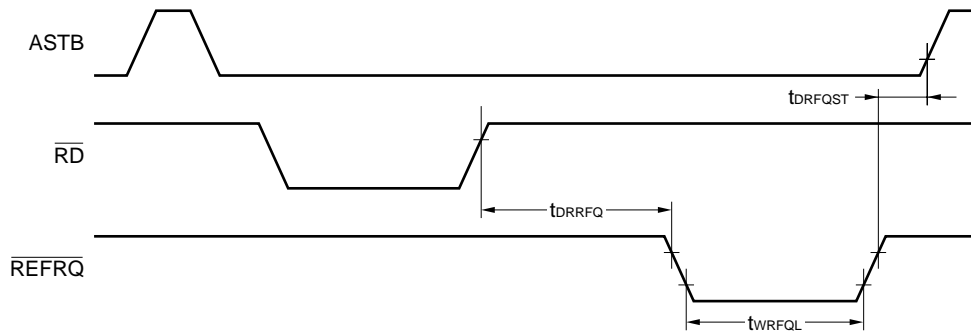

(4) Refresh after a write

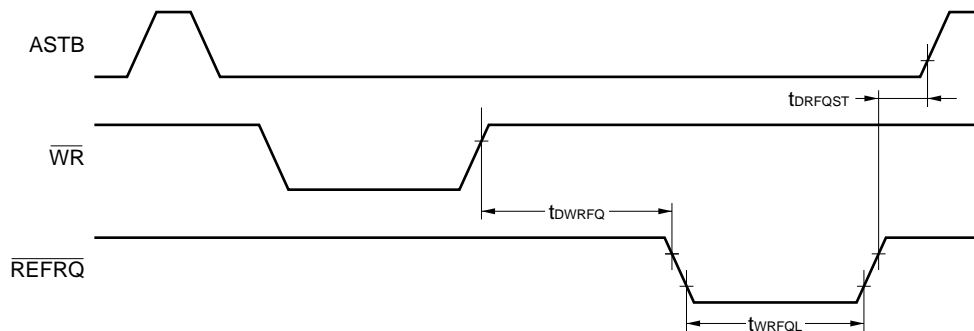



SERIAL OPERATION

★ (1) CSI

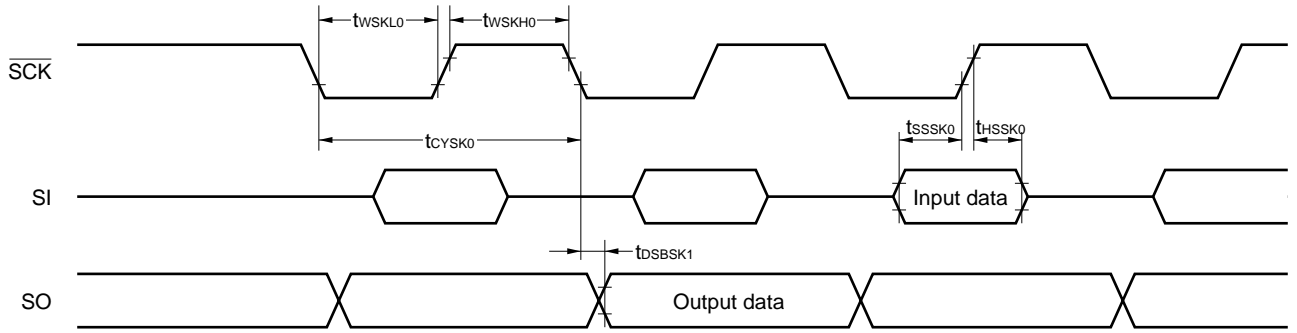

(2) IOE1, IOE2

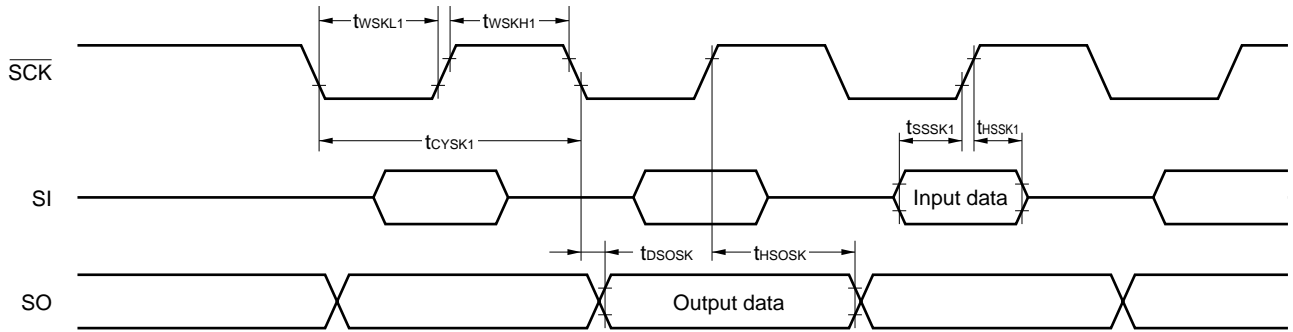

(3) UART, UART2

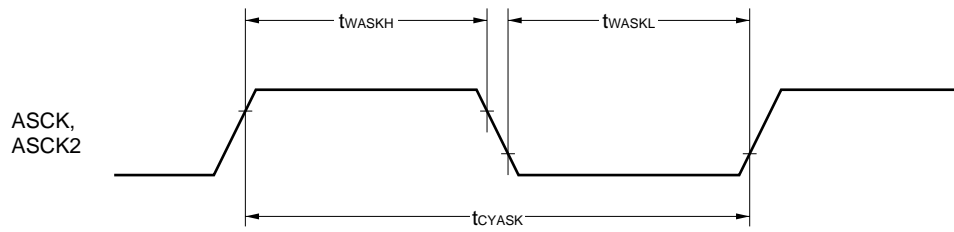

CLOCK OUTPUT TIMING

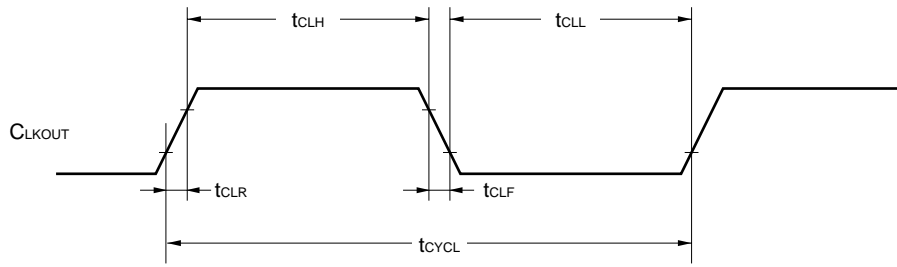

INTERRUPT INPUT TIMING

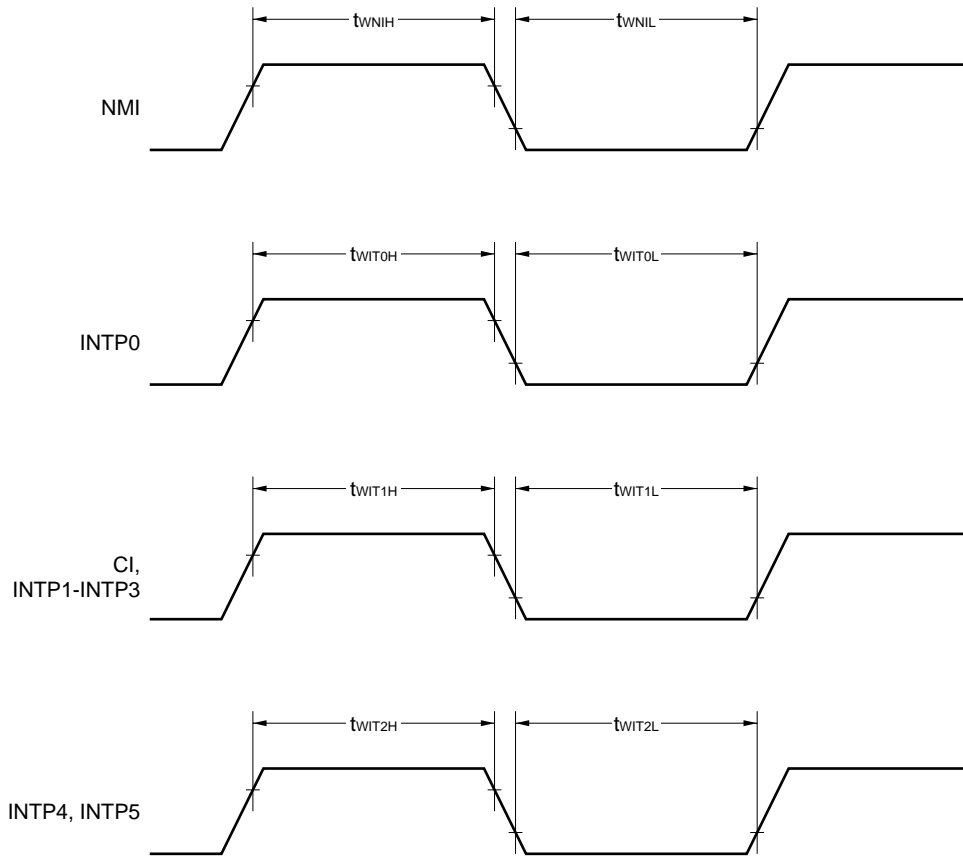

RESET INPUT TIMING

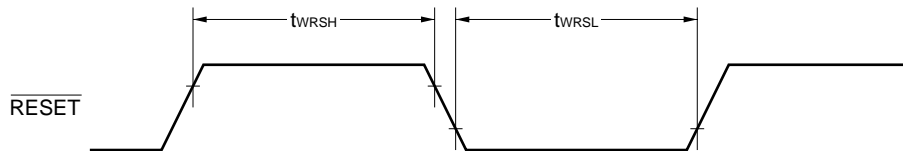

EXTERNAL CLOCK TIMING

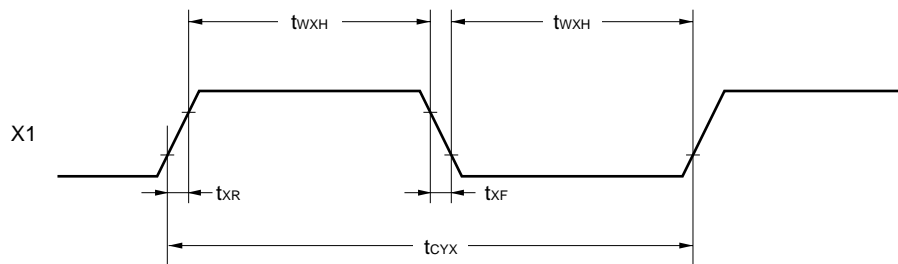

DATA RETENTION CHARACTERISTICS

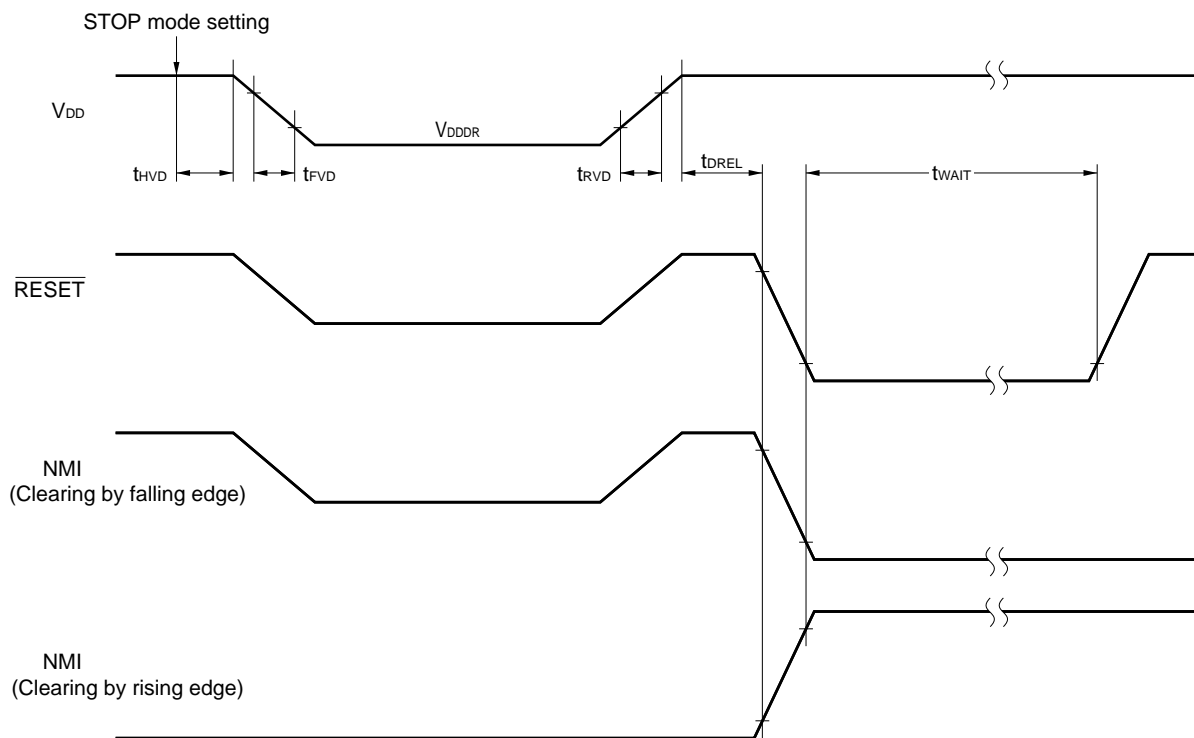

15. PACKAGE DRAWINGS

80 PIN PLASTIC QFP (14x14)

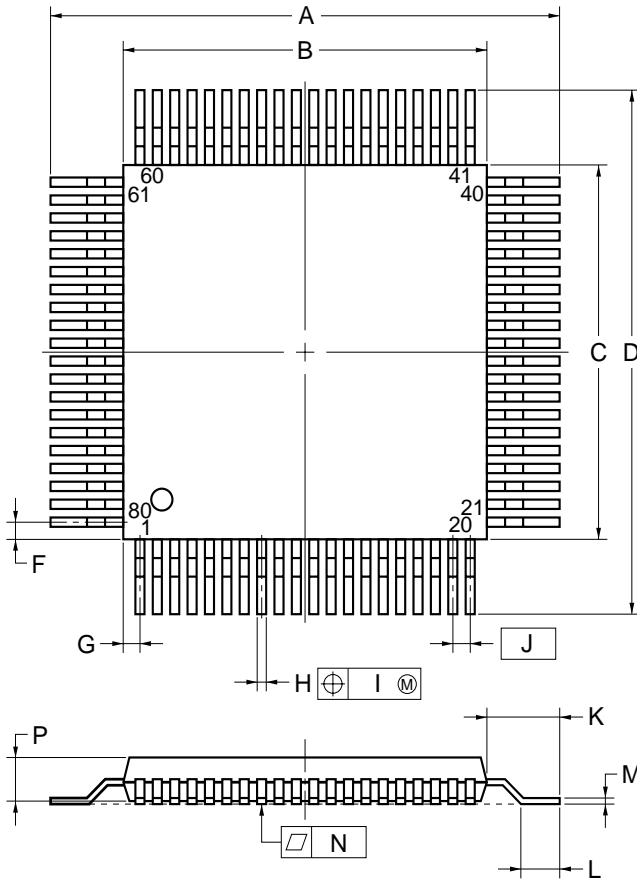

detail of lead end

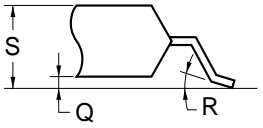

**NOTE**  
Each lead centerline is located within 0.13 mm (0.005 inch) of its true position (T.P.) at maximum material condition.

ITEM	MILLIMETERS	INCHES
A	17.2±0.4	0.677±0.016
B	14.0±0.2	0.551 <sup>+0.009</sup> <sub>-0.008</sub>
C	14.0±0.2	0.551 <sup>+0.009</sup> <sub>-0.008</sub>
D	17.2±0.4	0.677±0.016
F	0.825	0.032
G	0.825	0.032
H	0.30±0.10	0.012 <sup>+0.004</sup> <sub>-0.005</sub>
I	0.13	0.005
J	0.65 (T.P.)	0.026 (T.P.)
K	1.6±0.2	0.063±0.008
L	0.8±0.2	0.031 <sup>+0.009</sup> <sub>-0.008</sub>
M	0.15 <sup>+0.10</sup> <sub>-0.05</sub>	0.006 <sup>+0.004</sup> <sub>-0.003</sub>
N	0.10	0.004
P	2.7±0.1	0.106 <sup>+0.005</sup> <sub>-0.004</sub>
Q	0.1±0.1	0.004±0.004
R	5°±5°	5°±5°
S	3.0 MAX.	0.119 MAX.

S80GC-65-3B9-5

**Remark** The shape and material of the ES version are the same as those of the corresponding mass-produced product.

80 PIN PLASTIC QFP (14×14)

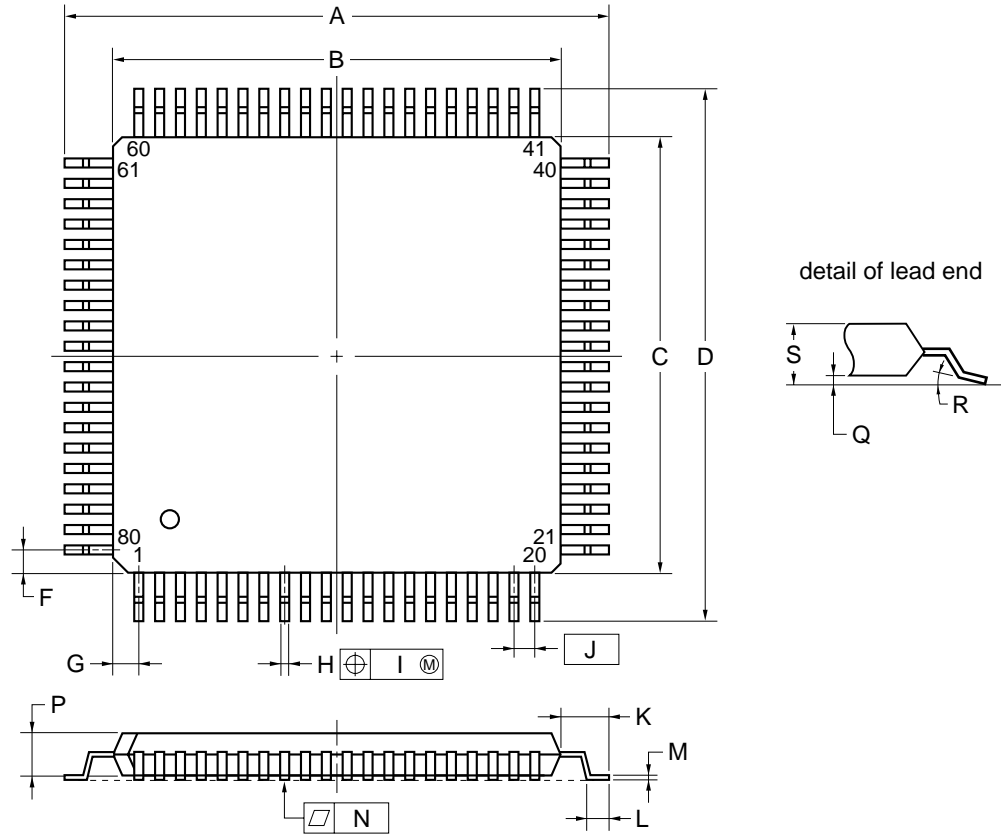

NOTE

Each lead centerline is located within 0.13 mm (0.005 inch) of its true position (T.P.) at maximum material condition.

ITEM	MILLIMETERS	INCHES
A	17.20±0.20	0.677±0.008
B	14.00±0.20	0.551 <sup>+0.009</sup> <sub>-0.008</sub>
C	14.00±0.20	0.551 <sup>+0.009</sup> <sub>-0.008</sub>
D	17.20±0.20	0.677±0.008
F	0.825	0.032
G	0.825	0.032
H	0.32±0.06	0.013 <sup>+0.002</sup> <sub>-0.003</sub>
I	0.13	0.005
J	0.65 (T.P.)	0.026 (T.P.)
K	1.60±0.20	0.063±0.008
L	0.80±0.20	0.031 <sup>+0.009</sup> <sub>-0.008</sub>
M	0.17 <sup>+0.03</sup> <sub>-0.07</sub>	0.007 <sup>+0.001</sup> <sub>-0.003</sub>
N	0.10	0.004
P	1.40±0.10	0.055±0.004
Q	0.125±0.075	0.005±0.003
R	3° <sup>+7°</sup> <sub>-3°</sub>	3° <sup>+7°</sup> <sub>-3°</sub>
S	1.70 MAX.	0.067 MAX.

P80GC-65-8BT

**Remark** The shape and material of the ES version are the same as those of the corresponding mass-produced product.

80 PIN PLASTIC TQFP (FINE PITCH) (□12)

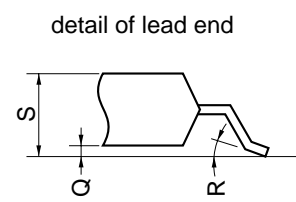
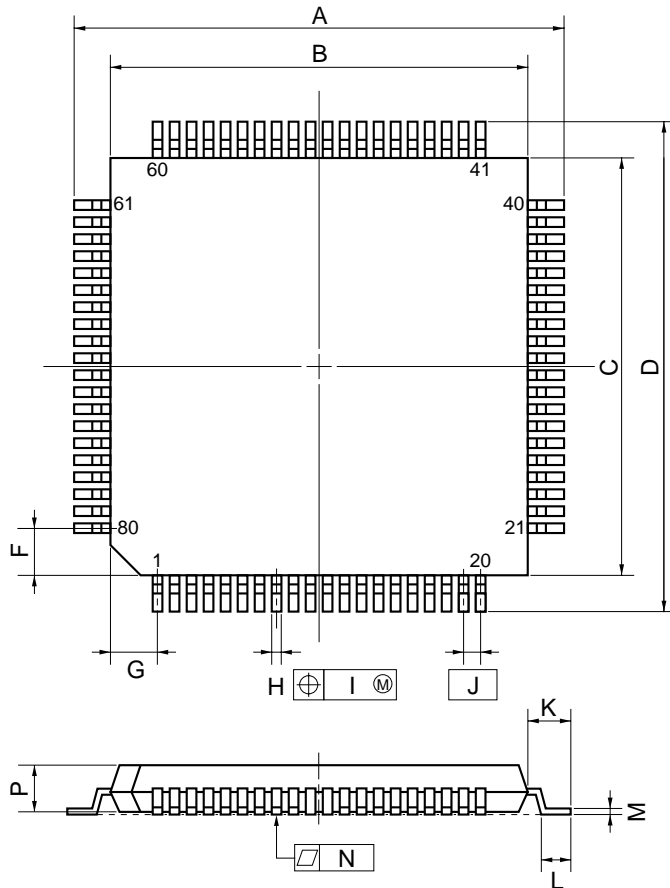

**NOTE**  
 Each lead centerline is located within 0.10 mm (0.004 inch) of its true position (T.P.) at maximum material condition.

ITEM	MILLIMETERS	INCHES
A	14.0±0.2	0.551 <sup>+0.009</sup> <sub>-0.008</sub>
B	12.0±0.2	0.472 <sup>+0.009</sup> <sub>-0.008</sub>
C	12.0±0.2	0.472 <sup>+0.009</sup> <sub>-0.008</sub>
D	14.0±0.2	0.551 <sup>+0.009</sup> <sub>-0.008</sub>
F	1.25	0.049
G	1.25	0.049
H	0.22 <sup>+0.05</sup> <sub>-0.04</sub>	0.009±0.002
I	0.10	0.004
J	0.5 (T.P.)	0.020 (T.P.)
K	1.0±0.2	0.039 <sup>+0.009</sup> <sub>-0.008</sub>
L	0.5±0.2	0.020 <sup>+0.008</sup> <sub>-0.009</sub>
M	0.145 <sup>+0.055</sup> <sub>-0.045</sub>	0.006±0.002
N	0.10	0.004
P	1.05	0.041
Q	0.05±0.05	0.002±0.002
R	5°±5°	5°±5°
S	1.27 MAX.	0.050 MAX.

P80GK-50-BE9-4

**Remark** The shape and material of the ES version are the same as those of the corresponding mass-produced product.

★ 16. RECOMMENDED SOLDERING CONDITIONS

The conditions listed below shall be met when soldering the μPD784035, μPD784036, μPD784037, or μPD784038.

For details of the recommended soldering conditions, refer to our document **Semiconductor Device Mounting Technology Manual (C10535E)**.

Please consult with our sales offices in case any other soldering process is used, or in case soldering is done under different conditions.

**Table 16-1. Soldering Conditions for Surface-Mount Devices (1/2)**

- (1) μPD784035GC-xxx-3B9: 80-pin plastic QFP (14 × 14 × 2.7 mm)
- μPD784036GC-xxx-3B9: 80-pin plastic QFP (14 × 14 × 2.7 mm)
- μPD784037GC-xxx-3B9: 80-pin plastic QFP (14 × 14 × 2.7 mm)
- μPD784038GC-xxx-3B9: 80-pin plastic QFP (14 × 14 × 2.7 mm)

Soldering process	Soldering conditions	Symbol
Infrared ray reflow	Peak package's surface temperature: 235 °C Reflow time: 30 seconds or less (210 °C or more) Maximum allowable number of reflow processes: 3	IR35-00-3
VPS	Peak package's surface temperature: 215 °C Reflow time: 40 seconds or less (200 °C or more) Maximum allowable number of reflow processes: 3	VP15-00-3
Wave soldering	Solder temperature: 260 °C or less Flow time: 10 seconds or less Number of flow processes: 1 Preheating temperature : 120 °C max. (measured on the package surface)	WS60-00-1
Partial heating method	Terminal temperature: 300 °C or less Heat time: 3 seconds or less (for one side of a device)	-

**Caution Do not apply two or more different soldering methods to one chip (except for partial heating method for terminal sections).**

- (2) μPD784035GC-xxx-8BT: 80-pin plastic QFP (14 × 14 × 1.4 mm)
- μPD784036GC-xxx-8BT: 80-pin plastic QFP (14 × 14 × 1.4 mm)
- μPD784037GC-xxx-8BT: 80-pin plastic QFP (14 × 14 × 1.4 mm)
- μPD784038GC-xxx-8BT: 80-pin plastic QFP (14 × 14 × 1.4 mm)

Soldering process	Soldering conditions	Symbol
Infrared ray reflow	Peak package's surface temperature: 235 °C Reflow time: 30 seconds or less (210 °C or more) Maximum allowable number of reflow processes: 2	IR35-00-2
VPS	Peak package's surface temperature: 215 °C Reflow time: 40 seconds or less (200 °C or more) Maximum allowable number of reflow processes: 2	VP15-00-2
Wave soldering	Solder temperature: 260 °C or less Flow time: 10 seconds or less Number of flow processes: 1 Preheating temperature : 120 °C max. (measured on the package surface)	WS60-00-1
Partial heating method	Terminal temperature: 300 °C or less Heat time: 3 seconds or less (for one side of a device)	-

**Caution Do not apply two or more different soldering methods to one chip (except for partial heating method for terminal sections).**

Table 16-1. Soldering Conditions for Surface-Mount Devices (2/2)

- (3) μPD784035GK-xxx-BE9: 80-pin plastic TQFP (fine pitch) (12 × 12 mm)
- μPD784036GK-xxx-BE9: 80-pin plastic TQFP (fine pitch) (12 × 12 mm)
- μPD784037GK-xxx-BE9: 80-pin plastic TQFP (fine pitch) (12 × 12 mm)
- μPD784038GK-xxx-BE9: 80-pin plastic TQFP (fine pitch) (12 × 12 mm)

Soldering process	Soldering conditions	Symbol
Infrared ray reflow	Peak package's surface temperature: 235 °C Reflow time: 30 seconds or less (210 °C or more) Maximum allowable number of reflow processes: 2 Exposure limit: 7 days <sup>Note</sup> (10 hours of pre-baking is required at 125 °C afterward) <Caution> Non-heat-resistant trays, such as magazine and taping trays, cannot be baked before unpacking.	IR35-107-2
VPS	Peak package's surface temperature: 215 °C Reflow time: 40 seconds or less (200 °C or more) Maximum allowable number of reflow processes: 2 Exposure limit: 7 days <sup>Note</sup> (10 hours of pre-baking is required at 125 °C afterward) <Caution> Non-heat-resistant trays, such as magazine and taping trays, cannot be baked before unpacking.	VP15-107-2
Partial heating method	Terminal temperature: 300 °C or less Heat time: 3 seconds or less (for one side of a device)	-

**Note** Maximum number of days during which the product can be stored at a temperature of 25 °C and a relative humidity of 65 % or less after dry-pack package is opened.

**Caution** Do not apply two or more different soldering methods to one chip (except for partial heating method for terminal sections).



★ **APPENDIX A DEVELOPMENT TOOLS**

The following development tools are available for system development using the μPD784038.  
See also (5).

**(1) Language processing software**

RA78K4	Assembler package for all 78K/IV series models
CC78K4	C compiler package for all 78K/IV series models
DF784038	Device file for μPD784038 sub-series models
CC78K4-L	C compiler library source file for all 78K/IV series models

**(2) PROM write tools**

PG-1500	PROM programmer
PA-78P4026GC PA-78P4038GK PA-78P4026KK	Programmer adaptor, connects to PG-1500
PG-1500 controller	Control program for PG-1500

**(3) Debugging tools**

- When using the in-circuit emulator IE-78K4-NS

IE-78K4-NS	In-circuit emulator for all 78K/IV series models
IE-70000-MC-PS-B	Power supply unit for IE-78K4-NS
IE-70000-98-IF-C	Interface adapter when the PC-9800 series computer (other than a notebook) is used as the host machine
IE-70000-CD-IF	PC card and interface cable when a PC-9800 series notebook is used as the host machine
IE-70000-PC-IF-C	Interface adapter when the IBM PC/AT™ or compatible is used as the host machine
IE-784038-NS-EM1 <sup>Note</sup>	Emulation board for evaluating μPD784038 sub-series models
NP-80GC	Emulation probe for 80-pin plastic QFP (GC-3B9 type)
NP-80GK <sup>Note</sup>	Emulation probe for 80-pin plastic TQFP (GK-BE9 type)
EV-9200GC-80	Socket for mounting on target system board made for 80-pin plastic QFP (GC-3B9 type)
TGK-080SDW	Adapter for mounting on target system board made for 80-pin plastic TQFP (fine pitch) (GK-BE9 type)
EV-9900	Tool used to remove the μPD78P4038KK-T from the EV-9200GC-80
ID78K4-NS <sup>Note</sup>	Integrated debugger for IE-78K4-NS
SM78K4-NS	System simulator for all 78K/IV series models
DF784038	Device file for μPD784038 sub-series models

**Note** Under development

- When using the in-circuit emulator IE-784000-R

IE-784000-R	In-circuit emulator for all 78K/IV series models
IE-70000-98-IF-B IE-70000-98-IF-C <sup>Note</sup>	Interface adapter when the PC-9800 series computer (other than a notebook) is used as the host machine
IE-70000-98N-IF	Interface adapter and cable when a PC-9800 series notebook is used as the host machine
IE-70000-PC-IF-B IE-70000-PC-IF-C <sup>Note</sup>	Interface adapter when the IBM PC/AT or compatible is used as the host machine
IE-78000-R-SV3	Interface adapter and cable when the EWS is used as the host machine
IE-784038-NS-EM1 <sup>Note</sup> IE-784038-R-EM1	Emulation board for evaluating μPD784038 sub-series models
IE-78400-R-EM	Emulation board for all 78K/IV series models
IE-78K4-R-EX2 <sup>Note</sup>	Conversion board for 80 pins to use the IE-784038-NS-EM1 on the IE-784000-R. The board is not needed when the conventional product IE-784038-R-EM1 is used.
EP-78230GC-R	Emulation probe for 80-pin plastic QFP (GC-3B9 type)
EP-78054GK-R	Emulation probe for 80-pin plastic TQFP (fine pitch) (GK-BE9 type) for all μPD784038 sub-series
EV-9200GC-80	Socket for mounting on target system board made for 80-pin plastic QFP (GC-3B9 type)
TGK-080SDW	Adapter for mounting on target system board made for 80-pin plastic TQFP (fine pitch) (GK-BE9 type)
EV-9900	Tool used to remove the μPD78P4038KK-T from the EV-9200GC-80
ID78K4	Integrated debugger for IE-784000-R
SM78K4	System simulator for all 78K/IV series models
DF784038	Device file for μPD784038 sub-series models

**Note** Under development

**(4) Real-time OS**

RX78K/IV	Real-time OS for 78K/IV series models
MX78K4	OS for 78K/IV series models

**(5) Notes when using development tools**

- The ID78K-NS, ID78K4, and SM78K4 can be used in combination with the DF784038.
- The CC78K and RX78K/IV can be used in combination with the RA78K4 and DF784038.
- The NP-80GC is a product from Naito Densai Machida Mfg. Co., Ltd. (044-822-3813). Consult the NEC sales representative for purchasing.
- The TGK-080SDW is a product from TOKYO ELETECH CORPORATION.  
 Refer to: Daimaru Kogyo, Ltd.  
           Tokyo Electronic Components Division (03-3820-7112)  
           Osaka Electronic Components Division (06-244-6672)
- The host machines and operating systems corresponding to each software are shown below.

Host machine [OS] Software	PC	EWS
		PC-9800 Series [Windows™] IBM PC/AT and compatibles [Windows]
RA78K4	○ <b>Note</b>	○
CC78K4	○ <b>Note</b>	○
PG-1500 controller	○ <b>Note</b>	-
ID78K4-NS	○	-
ID78K4	○	○
SM78K4	○	-
RX78K/IV	○ <b>Note</b>	○
MX78K4	○ <b>Note</b>	○

**Note** Software under MS-DOS

★ APPENDIX B RELATED DOCUMENTS

Documents Related to Devices

Document name	Document No.	
	Japanese	English
μPD784031 Data Sheet	U11507J	U11507E
μPD7840335, 784036, 784037, 784038	U10847J	This manual
μPD78P4038 Data Sheet	U10848J	U10848E
μPD784038, 784038Y Sub-Series User's Manual, Hardware	U11316J	U11316E
μPD784038 Sub-Series Special Function Registers	U11090J	-
78K/IV Series User's Manual, Instruction	U10905J	U10905E
78K/IV Series Instruction Summary Sheet	U10594J	-
78K/IV Series Instruction Set	U10595J	-
78K/IV Series Application Note, Software Basic	U10095J	-

Documents Related to Development Tools (User's Manual)

Document name		Document No.	
		Japanese	English
RA78K4 Assembler Package	Operation	U11334J	U11334E
	Language	U11162J	U11162E
RA78K Series Structured Assembler Preprocessor		U11743J	U11743E
CC78K4 C Compiler	Operation	U11572J	U11572E
	Language	U11571J	U11571E
CC78K Series Library Source File		U12322J	U12322E
PG-1500 PROM Programmer		U11940J	U11940E
PG-1500 Controller PC-9800 Series (MS-DOS™) Base		EEU-704	EEU-1291
PG-1500 Controller IBM PC Series (PC DOS™) Base		EEU-5008	U10540E
IE-78K4-NS		Under creation	To be created
IE-784000-R		U12903J	EEU-1534
IE-784038-NS-EM1		To be created	To be created
IE-784038-R-EM1		U11383J	U11383E
EP-78230		EEU-985	EEU-1515
EP-78054GK-R		EEU-932	EEU-1468
SM78K4 System Simulator Windows Base	Reference	U10093J	U10093E
SM78K Series System Simulator	External Parts User Open Interface Specifications	U10092J	U10092E
ID78K4 Integrated Debugger	Reference	U12796J	U12796E
ID78K4 Integrated Debugger Windows Base	Reference	U10440J	U10440E
ID78K4 Integrated Debugger HP-UX, SunOS, NEW-OS Base	Reference	U11960J	U11960E

**Caution** The above documents may be revised without notice. Use the latest versions when you design application systems.

**Documents Related to Software to Be Incorporated into the Product (User's Manual)**

Document name		Document No.	
		Japanese	English
78K/IV Series Real-Time OS	Basic	U10603J	U10603E
	Installation	U10604J	U10604E
	Debugger	U10364J	-
OS for 78K/IV Series MX78K4	Basic	U11779J	-

**Other Documents**

Document name	Document No.	
	Japanese	English
IC PACKAGE MANUAL	C10943X	
Semiconductor Device Mounting Technology Manual	C10535J	C10535E
Quality Grades on NEC Semiconductor Device	C11531J	C11531E
NEC Semiconductor Device Reliability/Quality Control System	C10983J	C10983E
Guide to Prevent Damage for Semiconductor Devices by Electrostatic Discharge (ESD)	U11892J	E11892E
Semiconductor Device Quality Control/Reliability Handbook	C12769J	-
Guide for Products Related to Microcomputer: Other Companies	C11416J	-

**Caution** The above documents may be revised without notice. Use the latest versions when you design application systems.

## NOTES FOR CMOS DEVICES

### ① PRECAUTION AGAINST ESD FOR SEMICONDUCTORS

**Note:** Strong electric field, when exposed to a MOS device, can cause destruction of the gate oxide and ultimately degrade the device operation. Steps must be taken to stop generation of static electricity as much as possible, and quickly dissipate it once, when it has occurred. Environmental control must be adequate. When it is dry, humidifier should be used. It is recommended to avoid using insulators that easily build static electricity. Semiconductor devices must be stored and transported in an anti-static container, static shielding bag or conductive material. All test and measurement tools including work bench and floor should be grounded. The operator should be grounded using wrist strap. Semiconductor devices must not be touched with bare hands. Similar precautions need to be taken for PW boards with semiconductor devices on it.

### ② HANDLING OF UNUSED INPUT PINS FOR CMOS

**Note:** No connection for CMOS device inputs can be cause of malfunction. If no connection is provided to the input pins, it is possible that an internal input level may be generated due to noise, etc., hence causing malfunction. CMOS device behave differently than Bipolar or NMOS devices. Input levels of CMOS devices must be fixed high or low by using a pull-up or pull-down circuitry. Each unused pin should be connected to  $V_{DD}$  or GND with a resistor, if it is considered to have a possibility of being an output pin. All handling related to the unused pins must be judged device by device and related specifications governing the devices.

### ③ STATUS BEFORE INITIALIZATION OF MOS DEVICES

**Note:** Power-on does not necessarily define initial status of MOS device. Production process of MOS does not define the initial operation status of the device. Immediately after the power source is turned ON, the devices with reset function have not yet been initialized. Hence, power-on does not guarantee out-pin levels, I/O settings or contents of registers. Device is not initialized until the reset signal is received. Reset operation must be executed immediately after power-on for devices having reset function.

**IEBus is a trademark of NEC Corporation.**

**MS-DOS and Windows are either registered trademarks or trademarks of Microsoft Corporation in the United States and/or other countries.**

**PC/AT and PC DOS are trademarks of IBM Corporation.**

**HP9000 series 700 and HP-UX are trademarks of Hewlett-Packard Company.**

**SPARCstation is a trademark of SPARC International, Inc.**

**SunOS is a trademark of Sun Microsystems, Inc.**

**NEWS and NEWS-OS are trademarks of SONY Corporation.**

## Regional Information

Some information contained in this document may vary from country to country. Before using any NEC product in your application, please contact the NEC office in your country to obtain a list of authorized representatives and distributors. They will verify:

- Device availability
- Ordering information
- Product release schedule
- Availability of related technical literature
- Development environment specifications (for example, specifications for third-party tools and components, host computers, power plugs, AC supply voltages, and so forth)
- Network requirements

In addition, trademarks, registered trademarks, export restrictions, and other legal issues may also vary from country to country.

### **NEC Electronics Inc. (U.S.)**

Santa Clara, California  
Tel: 408-588-6000  
800-366-9782  
Fax: 408-588-6130  
800-729-9288

### **NEC Electronics (Germany) GmbH**

Duesseldorf, Germany  
Tel: 0211-65 03 02  
Fax: 0211-65 03 490

### **NEC Electronics (UK) Ltd.**

Milton Keynes, UK  
Tel: 01908-691-133  
Fax: 01908-670-290

### **NEC Electronics Italiana s.r.l.**

Milano, Italy  
Tel: 02-66 75 41  
Fax: 02-66 75 42 99

### **NEC Electronics (Germany) GmbH**

Benelux Office  
Eindhoven, The Netherlands  
Tel: 040-2445845  
Fax: 040-2444580

### **NEC Electronics (France) S.A.**

Velizy-Villacoublay, France  
Tel: 01-30-67 58 00  
Fax: 01-30-67 58 99

### **NEC Electronics (France) S.A.**

Spain Office  
Madrid, Spain  
Tel: 01-504-2787  
Fax: 01-504-2860

### **NEC Electronics (Germany) GmbH**

Scandinavia Office  
Taebly, Sweden  
Tel: 08-63 80 820  
Fax: 08-63 80 388

### **NEC Electronics Hong Kong Ltd.**

Hong Kong  
Tel: 2886-9318  
Fax: 2886-9022/9044

### **NEC Electronics Hong Kong Ltd.**

Seoul Branch  
Seoul, Korea  
Tel: 02-528-0303  
Fax: 02-528-4411

### **NEC Electronics Singapore Pte. Ltd.**

United Square, Singapore 1130  
Tel: 253-8311  
Fax: 250-3583

### **NEC Electronics Taiwan Ltd.**

Taipei, Taiwan  
Tel: 02-719-2377  
Fax: 02-719-5951

### **NEC do Brasil S.A.**

Cumbica-Guarulhos-SP, Brasil  
Tel: 011-6465-6810  
Fax: 011-6465-6829



[MEMO]

Some related documents may be preliminary versions. Note, however, that whether a related document is preliminary is not indicated in this document.

The export of this product from Japan is regulated by the Japanese government. To export this product may be prohibited without governmental license, the need for which must be judged by the customer. The export or re-export of this product from a country other than Japan may also be prohibited without a license from that country. Please call an NEC sales representative.

No part of this document may be copied or reproduced in any form or by any means without the prior written consent of NEC Corporation. NEC Corporation assumes no responsibility for any errors which may appear in this document.

NEC Corporation does not assume any liability for infringement of patents, copyrights or other intellectual property rights of third parties by or arising from use of a device described herein or any other liability arising from use of such device. No license, either express, implied or otherwise, is granted under any patents, copyrights or other intellectual property rights of NEC Corporation or others.

While NEC Corporation has been making continuous effort to enhance the reliability of its semiconductor devices, the possibility of defects cannot be eliminated entirely. To minimize risks of damage or injury to persons or property arising from a defect in an NEC semiconductor device, customers must incorporate sufficient safety measures in its design, such as redundancy, fire-containment, and anti-failure features.

NEC devices are classified into the following three quality grades:

"Standard", "Special", and "Specific". The Specific quality grade applies only to devices developed based on a customer designated "quality assurance program" for a specific application. The recommended applications of a device depend on its quality grade, as indicated below. Customers must check the quality grade of each device before using it in a particular application.

**Standard:** Computers, office equipment, communications equipment, test and measurement equipment, audio and visual equipment, home electronic appliances, machine tools, personal electronic equipment and industrial robots

**Special:** Transportation equipment (automobiles, trains, ships, etc.), traffic control systems, anti-disaster systems, anti-crime systems, safety equipment and medical equipment (not specifically designed for life support)

**Specific:** Aircrafts, aerospace equipment, submersible repeaters, nuclear reactor control systems, life support systems or medical equipment for life support, etc.

The quality grade of NEC devices is "Standard" unless otherwise specified in NEC's Data Sheets or Data Books. If customers intend to use NEC devices for applications other than those specified for Standard quality grade, they should contact an NEC sales representative in advance.

Anti-radioactive design is not implemented in this product.