

1 dB LSB GaAs MMIC 5-BIT DIGITAL ATTENUATOR, DC - 10 GHz

Typical Applications

- Base Station Infrastructure
- Portable Wireless
- CATV & DBS
- MMDS & WirelessLAN
- Wireless Local Loop
- UNII & HiperLAN

Features

- Bandwidth: DC - 10 GHz
- Low Insertion Loss: 6.2 dB
- 31 dB Attenuation Range
- Fast Switching: 6 nS

Functional Diagram

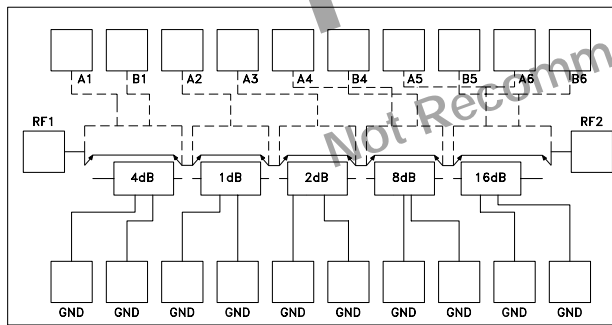

General Description

The HMC110 chip is a 5-bit digital attenuator with a 31 dB range in 1 dB steps. Each bit is activated by applying 0V to port A and disabled with -5 V to port A. Port B (as applicable) is biased with the complement of port A. See SMT packaged version HMC110G16 (hermetic).

Electrical Specifications, $T_A = +25^\circ\text{C}$, with 0/-5V Control

Parameter	Frequency	Min.	Typ.	Max.	Units
Reference Insertion Loss	DC - 5 GHz DC - 10 GHz		5.2 6.2	6.0 7.0	dB dB
Attenuation Range	DC - 10 GHz	27	31		dB
Return Loss	DC - 2 GHz DC - 10 GHz	12 8	15 10		dB dB
Attenuation Accuracy: 1 - 7 dB States 8 - 15 dB States 16 - 23 dB States 24 - 31 dB States	DC - 10 GHz DC - 10 GHz DC - 10 GHz DC - 10 GHz		+/- 0.5 dB +/- 5% of Setting Max. +/- 0.6 dB +/- 5% of Setting Max. +/- 0.6 dB +/- 8% of Setting Max. +/- 0.6 dB +/- 10% of Setting Max.		dB dB dB dB
Switching Characteristics tRISE, tFALL (10/90% RF) tON, tOFF (50% CTL to 10/90% RF)	DC - 10 GHz		3 6		ns ns
Input Power for 0.2 dB Compression Min Atten: Max Atten:	0.5 - 10 GHz		+22 +5		dBm dBm
Input Third Order Intercept Min Atten: Max Atten:	0.5 - 10 GHz		+44 +32		dBm dBm

1 dB LSB GaAs MMIC 5-BIT DIGITAL ATTENUATOR, DC - 10 GHz

Insertion Loss

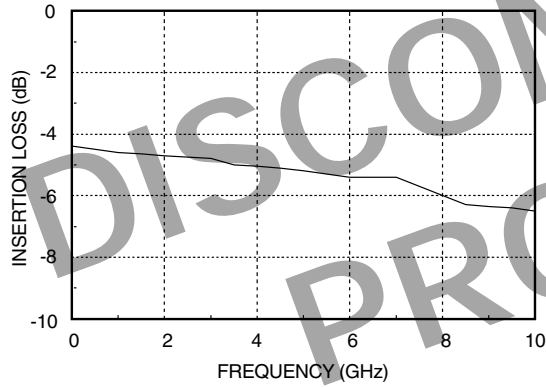

Relative Attenuation

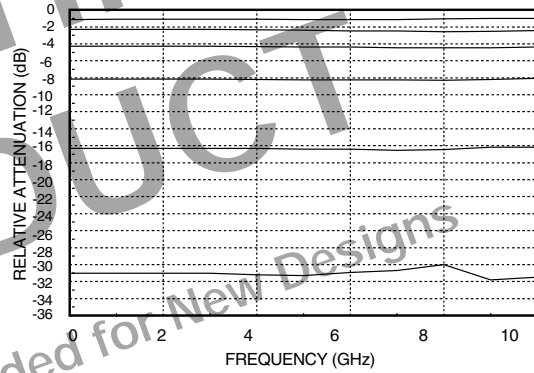

Relative Phase

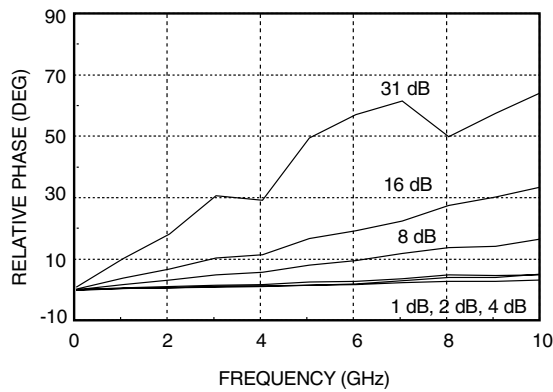

Return Loss

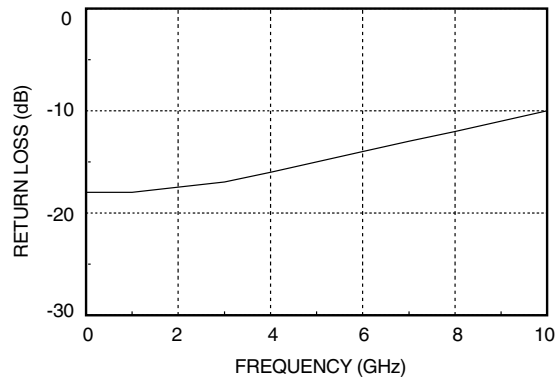

DISCONTINUED PRODUCT
Not Recommended for New Designs

1 dB LSB GaAs MMIC 5-BIT DIGITAL ATTENUATOR, DC - 10 GHz

Truth Table

Control Input								Att Set
4 dB Bit		1 dB	2 dB	8 dB Bit		16 dB Bit		
A1	B1	A2	A3	A4	B4	A5	B5	
High	Low	High	High	High	Low	High	Low	Ref
High	Low	Low	High	High	Low	High	Low	1dB
High	Low	High	Low	High	Low	High	Low	2dB
Low	High	High	High	High	Low	High	Low	4dB
High	Low	High	High	Low	High	High	Low	8dB
High	Low	High	High	High	Low	Low	High	16dB

Any combination of the above states will provide an attenuation approximately equal to the sum of the bits selected.

Control Voltages

State	Bias Condition
Low	0 to -0.2V @ 20 uA Max.
High	-3V @ 50uA Typ to -8V @ 500 uA Max.

Absolute Maximum Ratings

Control Voltage Range	+0.5 to -8.5 Vdc
Storage Temperature	-65 to +150 deg C
Operating Temperature	-55 to +125 deg C
RF Input Power (0.5 - 4 GHz)	+27 dBm
Insertion Loss State	+13 dBm
Any Attenuation State	+13 dBm

Outline Drawing (See DIE HANDLING NOTES in section 8)

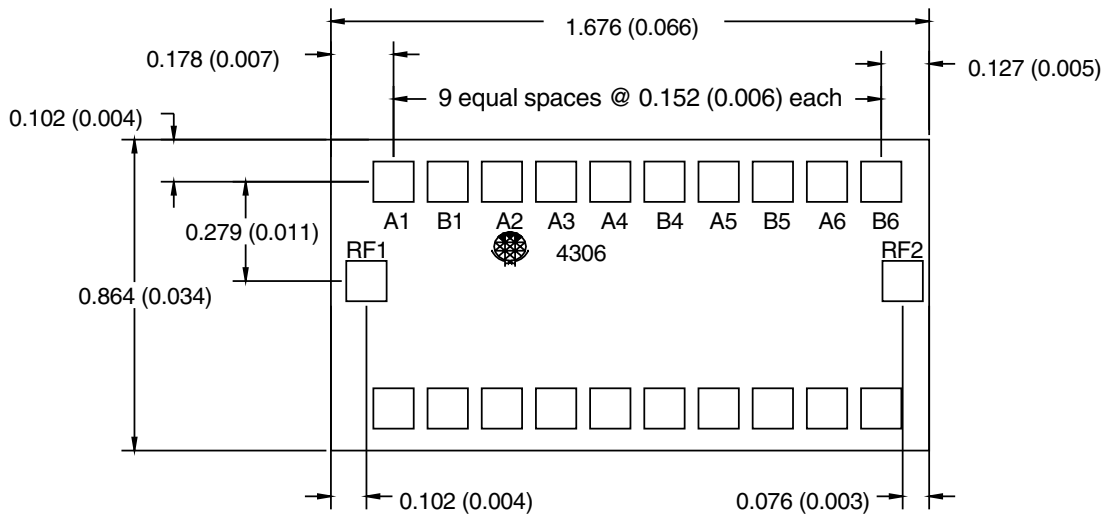

ALL DIMENSIONS IN MILLIMETERS (INCHES)
 ALL TOLERANCES ARE +/- 0.025 (0.001)
 DIE THICKNESS IS 0.203 (0.008), BACKSIDE IS NOT METALLIZED
 BOND PADS ARE 0.100 (0.004) SQUARE
 ALL UNLABELED BOND PADS ARE GROUND.
 BOND PAD METALLIZATION: GOLD.
 BACKSIDE METALLIZATION: NONE

1 dB LSB GaAs MMIC 5-BIT DIGITAL ATTENUATOR, DC - 10 GHz

Suggested Driver Circuit

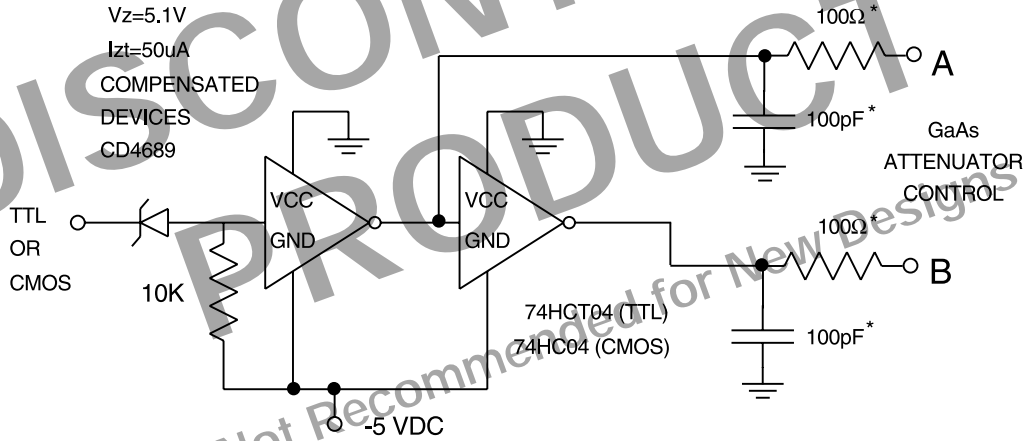

Simple driver using inexpensive standard logic ICs provides fast switching using minimum DC current.

*Recommended values to suppress unwanted RF signals at A/B control lines. You may adjust for switching speed considerations.