

# EPS13D2C2HD-14.318M TR

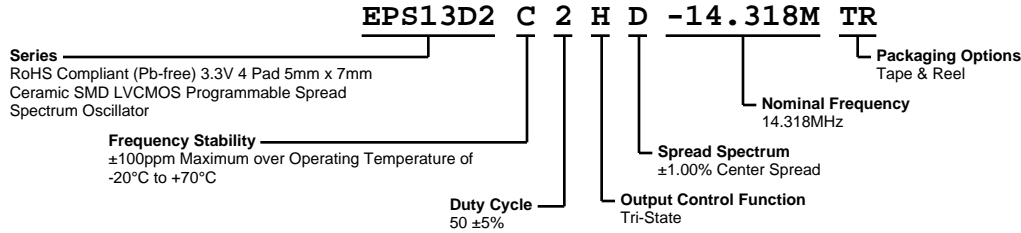

**ECLIPTEK**<sup>®</sup>  
CORPORATION



## ELECTRICAL SPECIFICATIONS

<b>Nominal Frequency</b>	14.318MHz
<b>Frequency Stability</b>	±100ppm Maximum over Operating Temperature of -20°C to +70°C (Inclusive of all conditions: Frequency Stability over the Operating Temperature Range, Supply Voltage Change, Output Load Change, First Year Aging at 25°C, Shock, and Vibration.)
<b>Aging at 25°C</b>	±5ppm First Year Maximum
<b>Supply Voltage</b>	3.3Vdc ±0.3Vdc
<b>Maximum Supply Voltage</b>	-0.5Vdc to +7.0Vdc
<b>Input Current</b>	30mA Maximum (Unloaded; Vdd=3.3Vdc)
<b>Output Voltage Logic High (Voh)</b>	Vdd-0.4Vdc Minimum (IOH=-8mA)
<b>Output Voltage Logic Low (Vol)</b>	0.4Vdc Maximum (IOL=+8mA)
<b>Rise/Fall Time</b>	2.7nSec Maximum (Measured at 20% to 80% of Waveform)
<b>Duty Cycle</b>	50 ±5% (Measured at 50% of Waveform)
<b>Load Drive Capability</b>	15pF Maximum
<b>Output Logic Type</b>	CMOS
<b>Output Control Function</b>	Tri-State (High Impedance Internal Pull Down Resistor of 100kOhms Typical on Pad 3, Internal Pull Up Resistor of 100kOhms Typical on Pad 1)
<b>Tri-State Input Voltage (Vih and Vil)</b>	70% of Vdd Minimum or No Connection to Enable Output, 30% of Vdd Maximum to Disable Output
<b>Tri-State Output Disable Time</b>	350nSec Maximum
<b>Tri-State Output Enable Time</b>	350nSec Maximum
<b>Disable Current</b>	20mA Maximum (Unloaded; Pad 1=Ground; Vdd=3.3Vdc)
<b>Spread Spectrum</b>	±1.00% Center Spread
<b>Modulation Frequency</b>	30kHz Minimum, 31.5kHz Typical, 33kHz Maximum
<b>Period Jitter</b>	700pSec Maximum (Cycle to Cycle; Spread Spectrum-On; Vdd=3.3Vdc)
<b>Start Up Time</b>	10mSec Maximum
<b>Storage Temperature Range</b>	-55°C to +125°C

## ENVIRONMENTAL & MECHANICAL SPECIFICATIONS

<b>Fine Leak Test</b>	MIL-STD-883, Method 1014, Condition A
<b>Gross Leak Test</b>	MIL-STD-883, Method 1014, Condition C
<b>Mechanical Shock</b>	MIL-STD-202, Method 213, Condition C
<b>Resistance to Soldering Heat</b>	MIL-STD-202, Method 210
<b>Resistance to Solvents</b>	MIL-STD-202, Method 215
<b>Solderability</b>	MIL-STD-883, Method 2003
<b>Temperature Cycling</b>	MIL-STD-883, Method 1010
<b>Vibration</b>	MIL-STD-883, Method 2007, Condition A

# EPS13D2C2HD-14.318M TR

## MECHANICAL DIMENSIONS (all dimensions in millimeters)

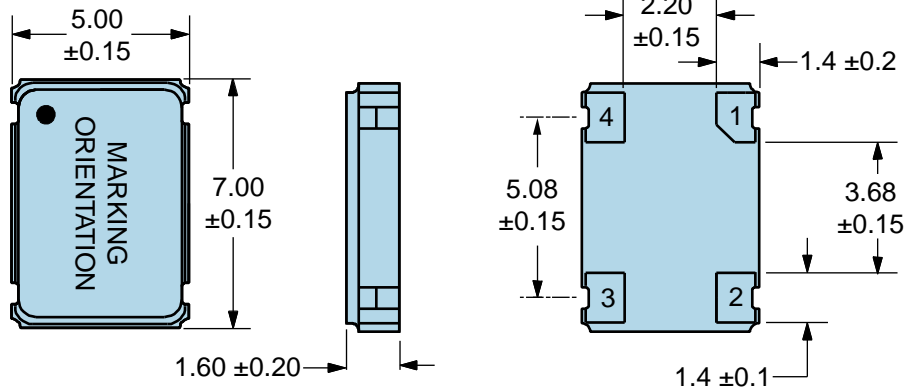

PIN	CONNECTION
1	Tri-State
2	Case/Ground
3	Output
4	Supply Voltage

LINE	MARKING
1	<b>ECLIPTEK</b>
2	<b>14.318M</b>
3	<b>SXXYYZ</b> <i>S=Configuration Designator</i> <i>XX=Ecliptek Manufacturing Code</i> <i>Y=Last Digit of the Year</i> <i>ZZ=Week of the Year</i>

## Suggested Solder Pad Layout

All Dimensions in Millimeters

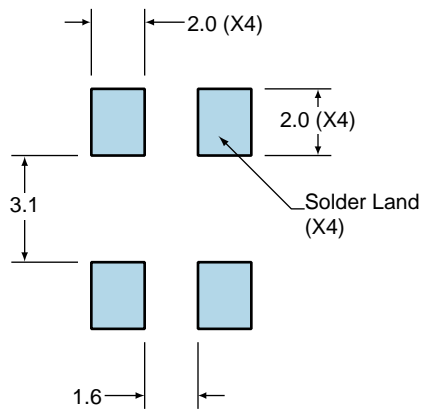

All Tolerances are  $\pm 0.1$

# EPS13D2C2HD-14.318M TR

## OUTPUT WAVEFORM & TIMING DIAGRAM



### Test Circuit for CMOS Output



Note 1: An external 0.1μF low frequency tantalum bypass capacitor in parallel with a 0.01μF high frequency ceramic bypass capacitor close to the package ground and V<sub>DD</sub> pin is required.

Note 2: A low capacitance (<12pF), 10X attenuation factor, high impedance (>10Mohms), and high bandwidth (>300MHz) passive probe is recommended.

Note 3: Capacitance value C<sub>L</sub> includes sum of all probe and fixture capacitance.

# EPS13D2C2HD-14.318M TR

## Tape & Reel Dimensions

Quantity Per Reel: 1,000 units

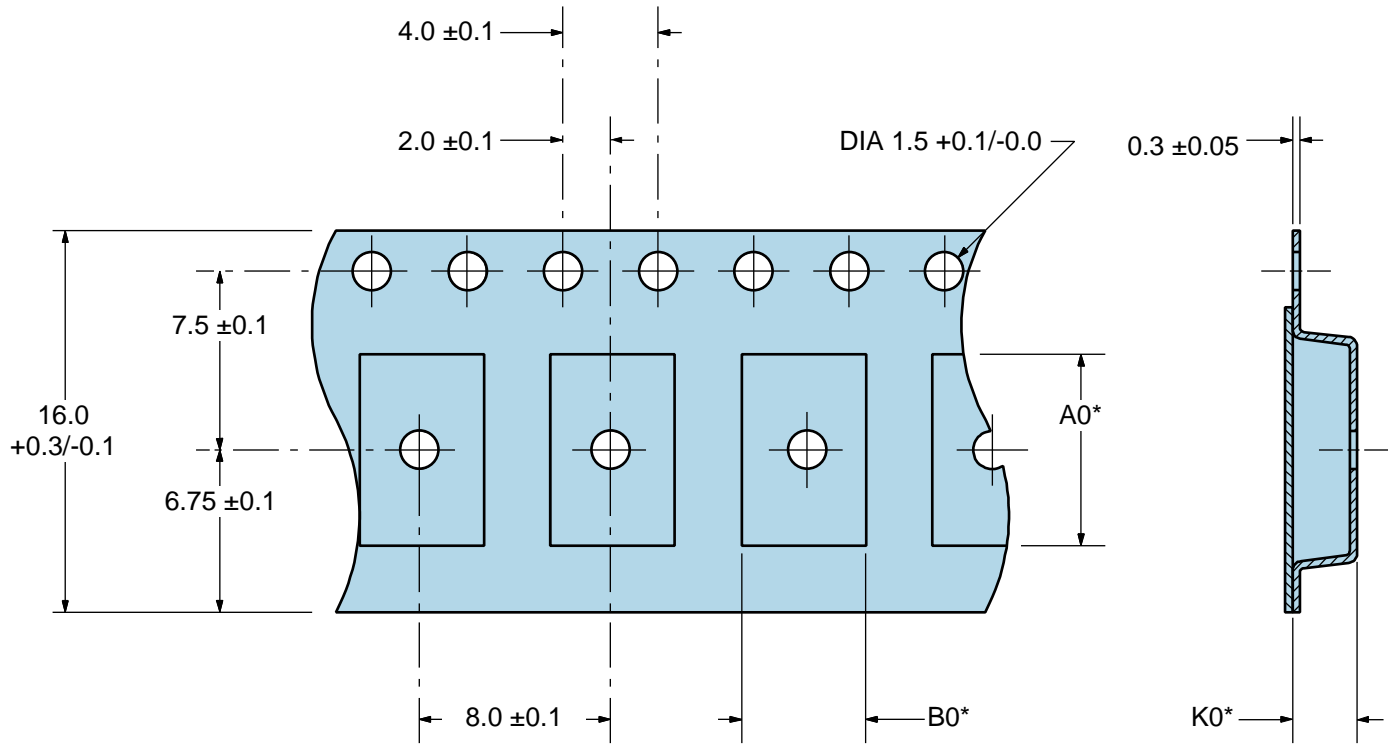

\*Compliant to EIA 481A

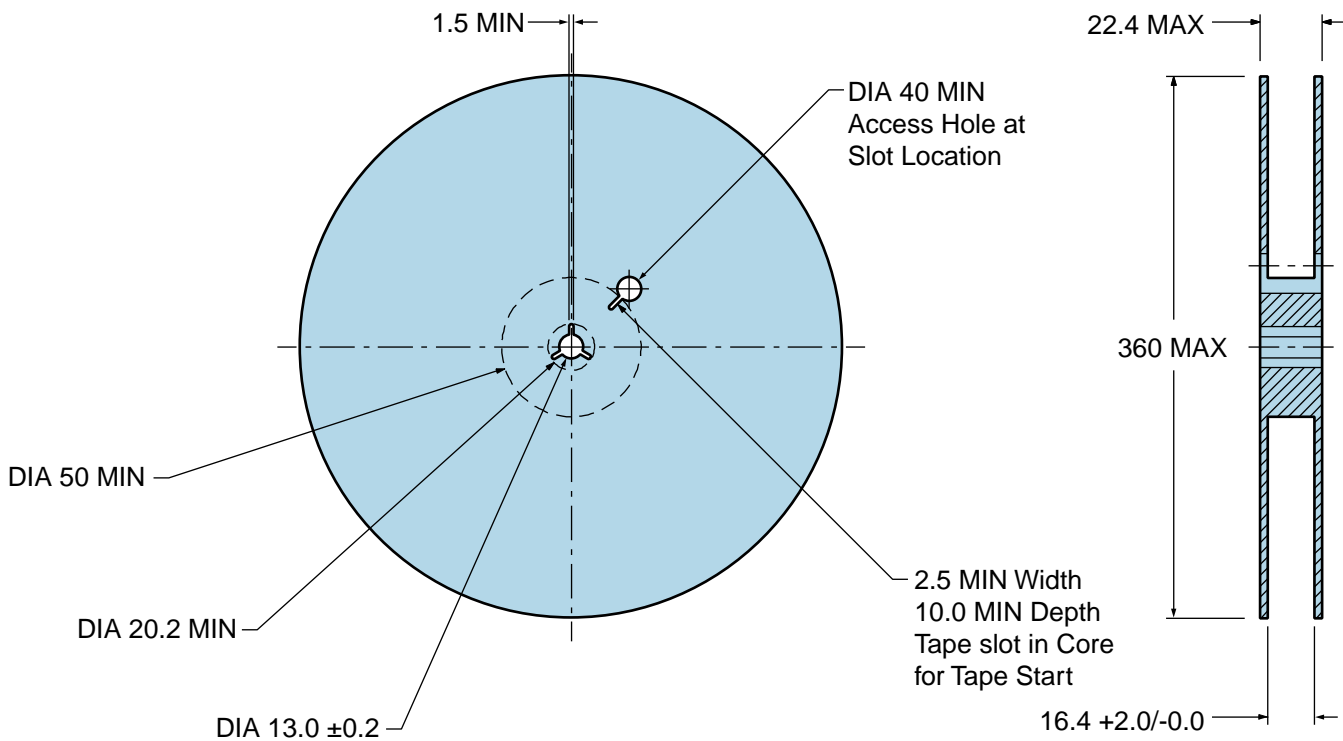

## Recommended Solder Reflow Methods



### High Temperature Infrared/Convection

<b>T<sub>s</sub> MAX to T<sub>L</sub> (Ramp-up Rate)</b>	3°C/second Maximum
<b>Preheat</b>	
- Temperature Minimum (T <sub>s</sub> MIN)	150°C
- Temperature Typical (T <sub>s</sub> TYP)	175°C
- Temperature Maximum (T <sub>s</sub> MAX)	200°C
- Time (t <sub>s</sub> MIN)	60 - 180 Seconds
<b>Ramp-up Rate (T<sub>L</sub> to T<sub>p</sub>)</b>	3°C/second Maximum
<b>Time Maintained Above:</b>	
- Temperature (T <sub>L</sub> )	217°C
- Time (t <sub>L</sub> )	60 - 150 Seconds
<b>Peak Temperature (T<sub>p</sub>)</b>	260°C Maximum for 10 Seconds Maximum
<b>Target Peak Temperature (T<sub>p</sub> Target)</b>	250°C +0/-5°C
<b>Time within 5°C of actual peak (t<sub>p</sub>)</b>	20 - 40 seconds
<b>Ramp-down Rate</b>	6°C/second Maximum
<b>Time 25°C to Peak Temperature (t)</b>	8 minutes Maximum
<b>Moisture Sensitivity Level</b>	Level 1

## Recommended Solder Reflow Methods



### Low Temperature Infrared/Convection 240°C

<b>T<sub>s</sub> MAX to T<sub>L</sub> (Ramp-up Rate)</b>	5°C/second Maximum
<b>Preheat</b>	
- Temperature Minimum (T <sub>s</sub> MIN)	N/A
- Temperature Typical (T <sub>s</sub> TYP)	150°C
- Temperature Maximum (T <sub>s</sub> MAX)	N/A
- Time (t <sub>s</sub> MIN)	60 - 120 Seconds
<b>Ramp-up Rate (T<sub>L</sub> to T<sub>P</sub>)</b>	5°C/second Maximum
<b>Time Maintained Above:</b>	
- Temperature (T <sub>L</sub> )	150°C
- Time (t <sub>L</sub> )	200 Seconds Maximum
<b>Peak Temperature (T<sub>P</sub>)</b>	240°C Maximum
<b>Target Peak Temperature (T<sub>P</sub> Target)</b>	240°C Maximum 1 Time / 230°C Maximum 2 Times
<b>Time within 5°C of actual peak (t<sub>p</sub>)</b>	10 seconds Maximum 2 Times / 80 seconds Maximum 1 Time
<b>Ramp-down Rate</b>	5°C/second Maximum
<b>Time 25°C to Peak Temperature (t)</b>	N/A
<b>Moisture Sensitivity Level</b>	Level 1

### Low Temperature Manual Soldering

185°C Maximum for 10 seconds Maximum, 2 times Maximum.

### High Temperature Manual Soldering

260°C Maximum for 5 seconds Maximum, 2 times Maximum.