

TITLE  
 INDUCTOR,  
 PQ3211,  
 3.55  $\mu$ H, 37.5 ADC

**SCHOTT**  
 CORPORATION  
 1000 PARKERS LAKE ROAD  
 WAYZATA, MN 55391

AGENCY APPROVAL:  
 N/A

PART NUMBER  
**35071**  
 REV B PAGE 1 END

**SPECIFICATIONS**

1. INDUCTANCE @ 0.01 V, 100 KHz: 3.20 - 3.90  $\mu$ H
2. DC RESISTANCE: 1.62 mOHM MAX
3. HIPOT (2 SECONDS, 5 mA MAX):  
 300 VRMS WINDING TO CORE.

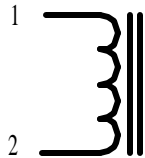

SUGGESTED PCB  
 FOOTPRINT  
 IN  
 (mm)

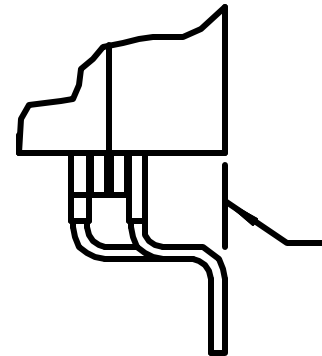
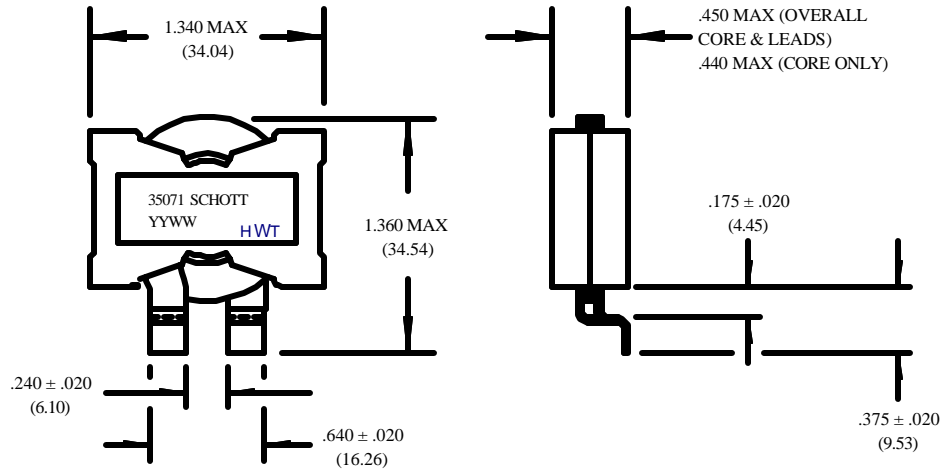
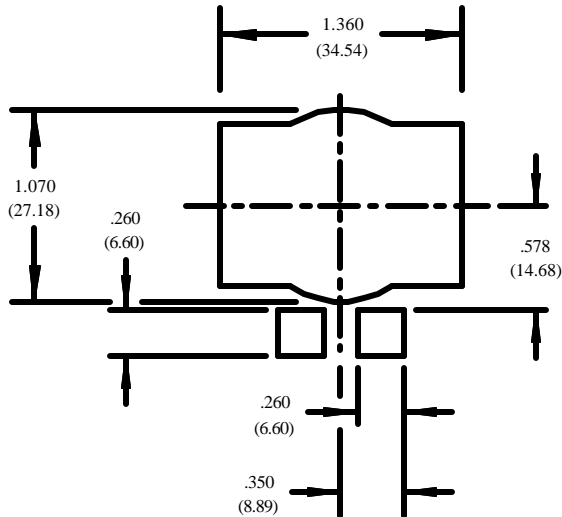

LEAD SURFACE  
 COPLANAR  
 WITHIN .005 (.127)

TOLERANCES UNLESS OTHERWISE NOTED	2 PLACE	3 PLACE	ANGLE
	± REF	± REF	± °