



## Model 1935F Coaxial DFB Laser Diode

### O-Band CWDM, CATV Forward Path 47 MHz – 1002 MHz

Emcore's Model 1935F DFB lasers offer a low cost solution for linear fiberoptic links. These components can be cooled with external thermoelectric coolers for high stability, or run without TEC's to reduce power consumption. The DFB laser builds upon Ortel's long history of high performance, leading edge designs in CATV, wireless, and high speed digital applications. The laser diode devices are packaged in a compact hermetic assembly together with monitor photodiode and isolator, for flexible integration into various transmitter configurations.

#### Applications

- Video signal distribution in HFC and FTTx nodes
- High linearity, low power fiber links

#### Features

- Linear DFB laser design
- Output power up to 10 dBm available
- Bandwidth 47 - 1002 MHz
- RoHS compliance
- Optical Isolator
- Low power consumption
- Monitor photodiode

#### Performance Highlights

	Min	Typical	Max	Units	
Operating Case Temperature Range	-40	-	80	°C	
Optical Output Power	3	-	5.8	dBm	
	6	-	8.8		
	9	-	9.8		
	10	-	11.8		
Frequency Range	5	-	2700	MHz	
Carrier-to-Noise Ratio (79 channels)	51	-	-	dB	
Composite Second Order (79 channels)	Standard Linearity			-57	dBc
	Enhanced Linearity			-60	
	Standard Linearity			-65	
Enhanced Linearity			-68		
O-Band CWDM Wavelength	1271, 1291, 1311, 1331, 1351, 1371			nm	
Optical Return Loss	45	-	-	dB	
Side Mode Suppression Ratio, CW	30	-	-	dB	

See following pages for complete specifications and conditions.

## Absolute Maximum Ratings<sup>1</sup>

Stresses in excess of the absolute maximum ratings can cause permanent damage to the device. These are absolute stress ratings only. Functional operation of the device is not implied at these or any other conditions in excess of those given in the operational sections of the data sheet. Exposure to absolute maximum ratings for extended periods can adversely affect device reliability.

Parameters	Symbol	Condition/Notes	MIN	MAX	Unit
Storage Temperature	T <sub>STG</sub>	Non-Operating	-40	85	°C
Operating Case Temperature	T <sub>OP</sub>	Continuous	-40	80	°C
Laser Diode Forward Current	I <sub>OP</sub>	CW	-	100	mA
Laser Diode Reverse Voltage	V <sub>R</sub>	Continuous	-	1.0	V
Photodiode Forward Current	I <sub>MPD</sub>	Continuous	-	2	mA
Photodiode Reverse Voltage	V <sub>MPD,R</sub>	Continuous	-	10	V
Average RF Input Power	PIN	60 Seconds	-	62	dBmV
Lead Soldering Temperature/Time	-	-	-	260/10	°C/sec
Relative Humidity	RH	Continuous	-	85	%
ESD	-	Human Body Model	-500	+500	V

1. Absolute maximum data are limited to system design only; proper device performance is not guaranteed over rating listed above. Operation beyond these maximum conditions may degrade device performance, lead to device failure, shorter lifetime, and will invalidate the device warranty.

# Model 1935F O-Band CWDM Coaxial DFB Forward Path Laser Diode

DATASHEET | JUNE 15, 2008

## Electrical/Optical Characteristics

Parameters	Symbol	Conditions/Notes	Min	Typ	Max	Unit
Optical Output Power	$P_O$	3 dBm version 6 dBm version 9 dBm version 10 dBm version	3 6 9 10	- - - -	5.8 8.8 9.8 11.8	dBm
Threshold Current	$I_{TH}$	$T_{case} = 25^{\circ}C$ $T_{case} = 45^{\circ}C$	- -	8 13	15 20	mA
Laser Bias Current	$I_{OP}$		-	-	80	mA
Forward Voltage	$V_F$	$I_{op}$	-	1.17	1.8	V
Laser Input Impedance	$Z$	-	2	4	8	$\Omega$
MPD Current	$I_{MPD}$	$V_{MPD} = 5V, I_{op} = 40 mA$	200	-	2000	$\mu A$
MPD Dark Current	$I_D$	$V_{MPD} = 5V, I_{op} = 0$ $T_{case} = 25^{\circ}C$	-	-	50	nA
O-Band CWDM Center Wavelength	$\lambda_c$	$I_{op}$ $T_{case} = 25^{\circ}C$	1267	1271	1275	nm
			1287	1291	1295	
			1307	1311	1315	
			1327	1331	1335	
			1347	1351	1355	
			1367	1371	1375	
Relative Intensity Noise	RIN	CW, $I_{op}$ , 5 MHz - 1002 MHz	-	-	-145	dB/Hz
Optical Isolation	ISO	$T_{case} = 25^{\circ}C$	30	-	-	dB
Spectral Width (-20 dB)	$\Delta\lambda$	$I_{op}, T_{case} = 25^{\circ}C$	-	0.1	1.0	nm
Side Mode Suppression Ratio	SMSR	$I_{op}, T_{case} = 25^{\circ}C$	30	45	-	dB
Tracking Error	ER	$I_{MON} = const$ $ER = 10\log(P_O/2.0)$ [dB]	-1	-	+1	dB
Optical Return Loss	ORL	$T_{case} = 25^{\circ}C$	35	-	-	dB

1. Referenced to base of TO header.

## RF Characteristics

Parameters	Symbol	Conditions/Notes	Min	Typ	Max	Unit
Bandwidth <sub>3 dB</sub>	BW	$I_{op}, T_{case} = 25^{\circ}C$	2700	-	-	MHz
Frequency Response Flatness <sup>1</sup>	$ S_{21} $	5 MHz < f < 1002 MHz	-	-	1	dB <sub>p-p</sub>
Response Up-tilt <sup>1</sup>		5 MHz < f < 1002 MHz	-1		3	dB
Carrier-to-Noise Ratio <sup>2,3,4</sup>	CNR	$I_{op}$ $T_{case} = 25^{\circ}C$	51	-	-	dB
Composite Second Order <sup>2,3,4</sup>	CSO	$I_{op}$ $T_{case} = 25^{\circ}C$	-	-	-57	dBc
			-	-	-60	
Composite Triple Beat <sup>2,3,4</sup>	CTB	$I_{op}$ $T_{case} = 25^{\circ}C$	-	-	-65	dBc
			-	-	-68	

- $I_{op}, T_{case} = 25^{\circ}C$ . Test with the laser Input pin matched to a 50 $\Omega$  system.
- 3.7% OMI, 79 NTSC unmodulated carriers (50 MHz to 550 MHz). 0 km fiber.
- Received power = 0 dBm.
- $I_{op}, T_{case} = 25^{\circ}C$ . Test with the laser Input pin matched to a 75 $\Omega$  system.

## Package Outline Drawing

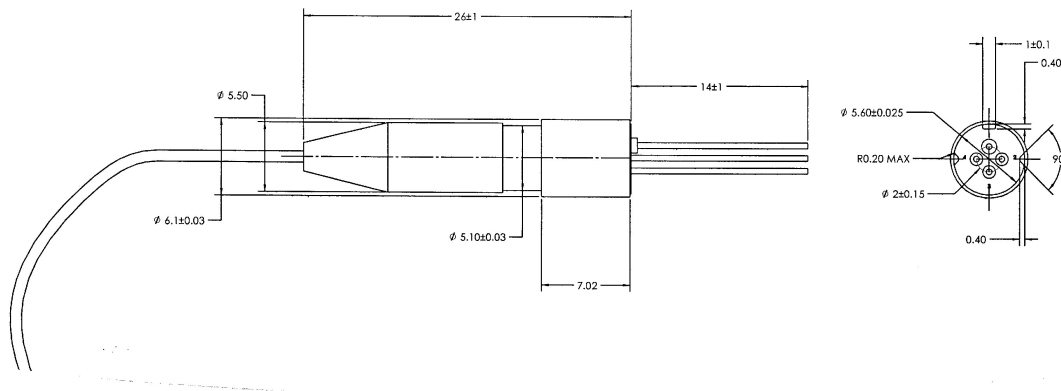

## Mounting Bracket

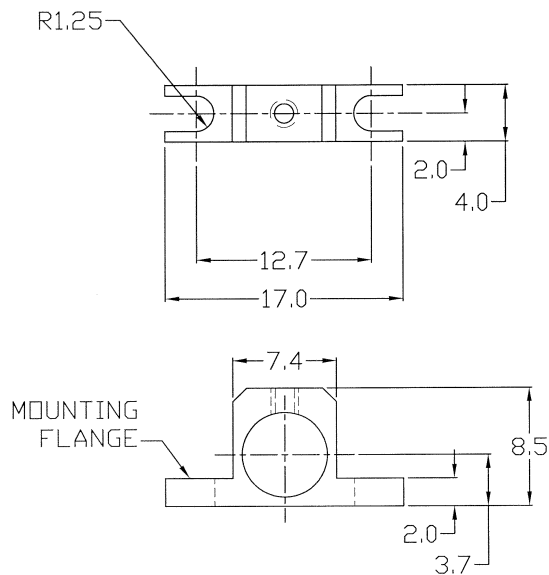

# Model 1935F O-Band CWDM Coaxial DFB Forward Path Laser Diode

DATASHEET | JUNE 15, 2008

## Reliability/Quality

Designed to meet qualification requirements of Telcordia™ (Bellcore) GR-468-CORE.

## Schematic and Pinout

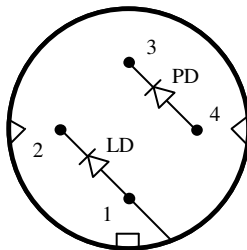

## Pin Definitions

Pin	Description
1	LD Anode, Case Ground
2	LD Cathode
3	PD Cathode
4	PD Anode

## Laser Safety

This product meets the appropriate standard in Title 21 of the Code of Federal Regulations (CFR). FDA/CDRH Class IIIb laser product. This device has been classified with the FDA/CDRH under accession number TBD.

Single-mode fiber pigtail with SC/APC connectors (standard).

Wavelength = 1.3  $\mu\text{m}$ .

Maximum power = 50 mW.

Because of size constraints, laser safety labeling (including an FDA class IIIb label) is not affixed to the module, but attached to the outside of the shipping carton.

Product is not shipped with power supply.

**Caution: Use of controls, adjustments and procedures other than those specified herein may result in hazardous laser radiation exposure.**

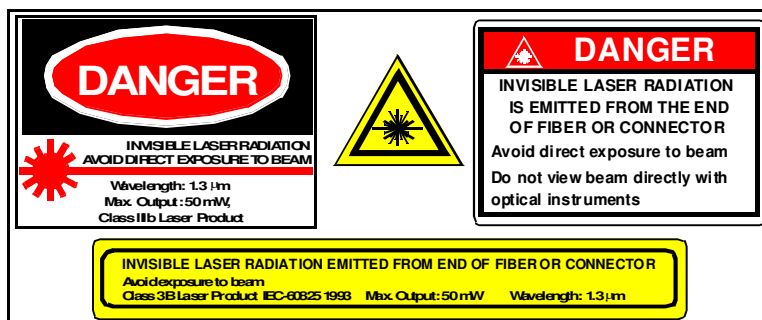

# Model 1935F O-Band CWDM Coaxial DFB Forward Path Laser Diode

DATASHEET | JUNE 15, 2008

## Ordering Code Definitions

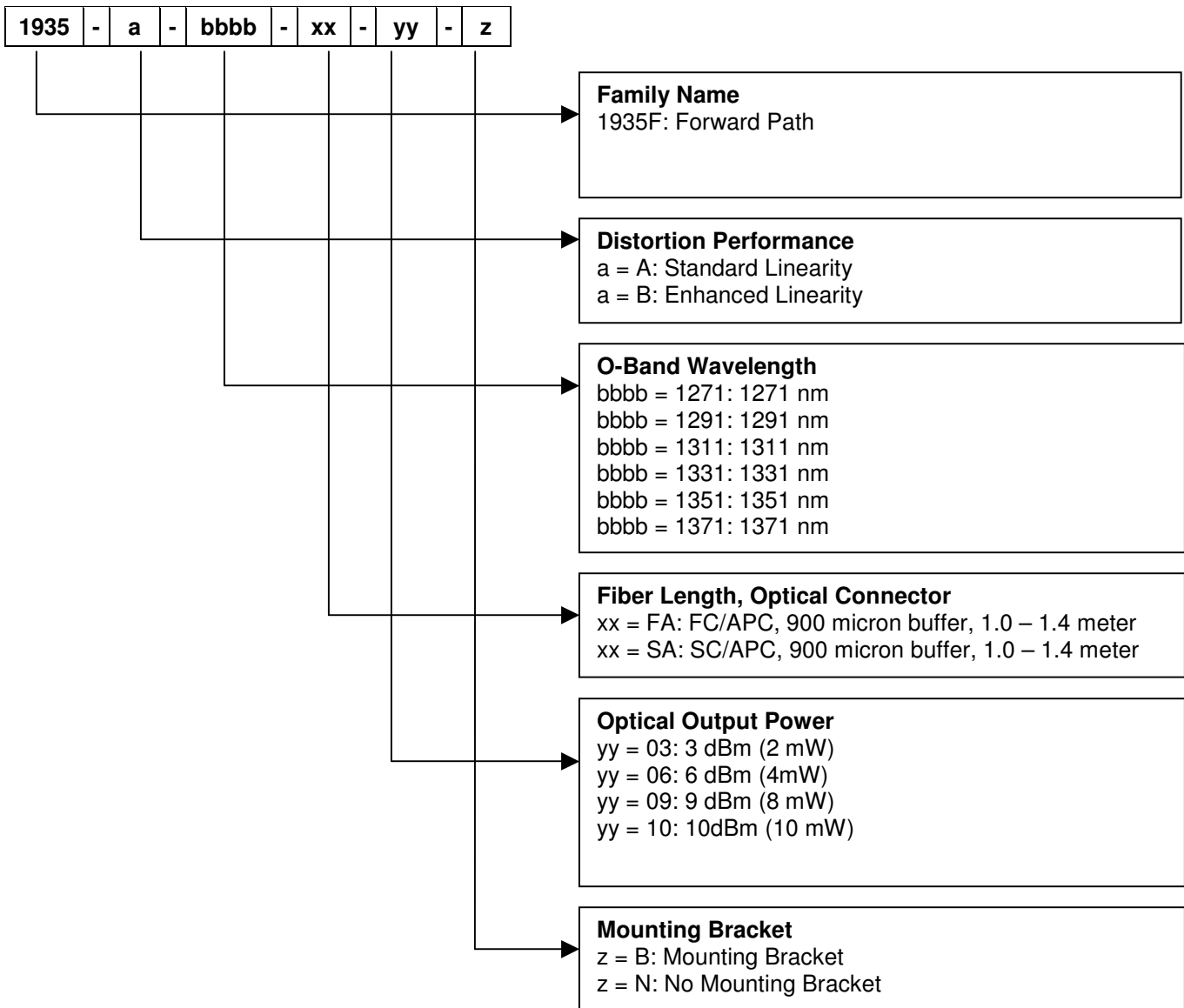

### Example

**1935F-B-1271-SA-10-N:** Forward Path Uncooled O-Band CWDM Coaxial Laser, Enhanced Linearity, 1271nm, SC/APC optical connector, 1.0 – 1.4 meter fiber pigtail, 900 micron fiber buffer, 10 dBm optical power, no mounting bracket.

Information contained herein is deemed to be reliable and accurate as of issue date. EMCORE reserves the right to change the design or specifications of the product at any time without notice. EMCORE and the EMCORE logo are trademarks of EMCORE Corporation.