

■ General Description

The AME8865 family of positive, CMOS linear regulators, provide low dropout voltage (400mV @ 1.5A) and excellent PSRR, thus making them ideal for power-saving systems. These rugged devices have both Thermal Shutdown, and Current limit to prevent device failure under the "Worst" of operating conditions.

The AME8865 is stable with an output capacitance of 4.7 μ F or larger.

■ Features

- 400mV Dropout @1.5A
- Excellent Line and Load Regulation
- Guaranteed 1.5A Output Current
- Fixed Output Voltage: 1V to 3.3V
- Adjustable Output Voltage from 0.8V to 4.5V
- Over Temperature/Over Current Protection
- RoHS Compliant and 100%Lead (Pb)-Free

■ Applications

- Motherboard, Desktop and Computer Peripherals
- LCD Monitor
- Handheld Device
- Data-Communication

■ Typical Application

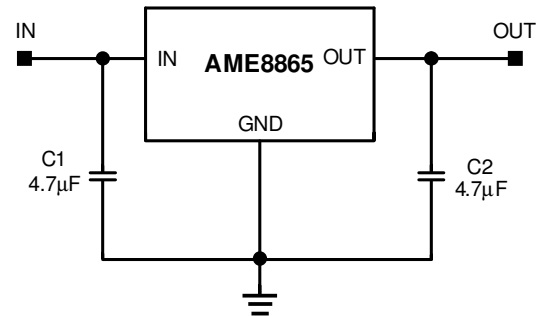

(Fixed Version)

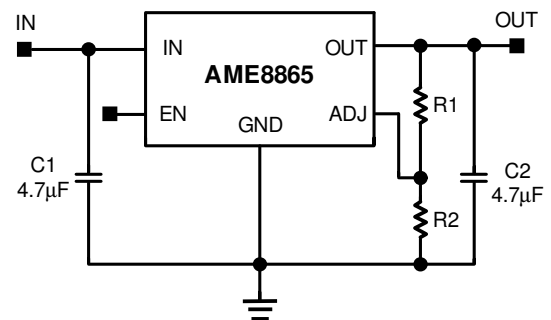

(Adjustable Version)

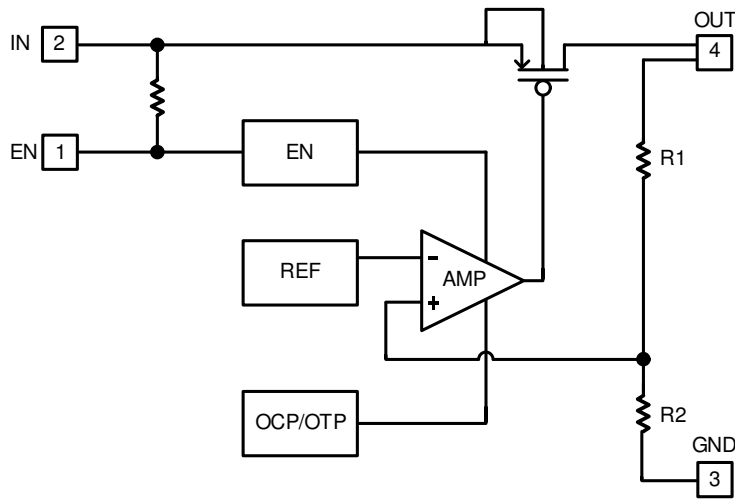
■ Functional Block Diagram

(Fixed Version)

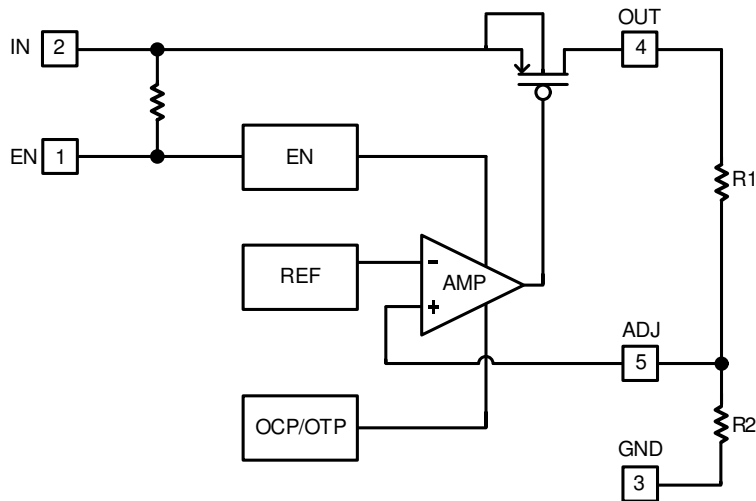

(Adjustable Version)

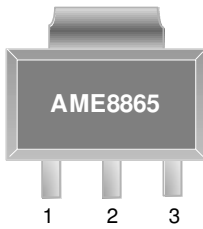
■ Pin Configuration
3 Pin
**SOT-223
Top View**

AME 8865-AGTxxx

1. IN
2. GND (TAB)
3. OUT

*** Die Attach:
Conductive Epoxy**

**SOT-223
Top View**

AME 8865-BGTxxx

1. GND
2. OUT (TAB)
3. IN

*** Die Attach:
Non-Conductive Epoxy**

**TO-252-2
Top View**

AME 8865-ACSxxx

1. IN
2. GND (TAB)
3. OUT

*** Die Attach:
Conductive Epoxy**

**TO-252-2
Top View**

AME 8865-BCSxxx

1. GND
2. OUT (TAB)
3. IN

*** Die Attach:
Non-Conductive Epoxy**

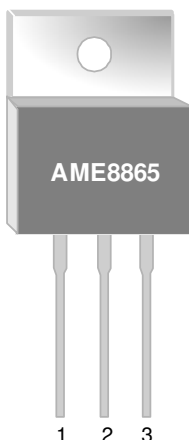
**TO-220-3
Top View**

AME 8865-ABTxxx

1. IN
2. GND (TAB)
3. OUT

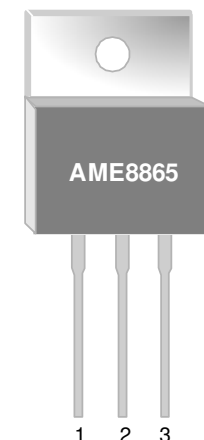
*** Die Attach:
Conductive Epoxy**

**TO-220-3
Top View**

AME 8865-BBTxxx

1. GND
2. OUT (TAB)
3. IN

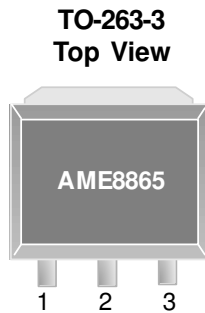
*** Die Attach:
Non-Conductive Epoxy**

■ Pin Configuration (Contd.)
3 Pin

AME 8865-ADTxxx

1. IN
2. GND (TAB)
3. OUT

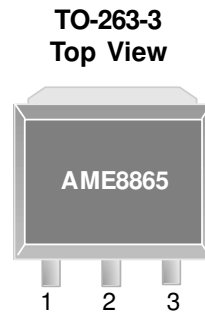
*** Die Attach:
Conductive Epoxy**

AME 8865-BDTxxx

1. GND
2. OUT (TAB)
3. IN

*** Die Attach:
Non-Conductive Epoxy**

AME 8865-ADSxxx

1. IN
2. GND (TAB)
3. OUT

*** Die Attach:
Conductive Epoxy**

AME 8865-BDSxxx

1. GND
2. OUT (TAB)
3. IN

*** Die Attach:
Non-Conductive Epoxy**

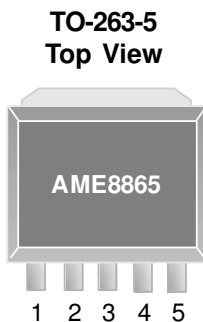
5 Pin

AME 8865-ADVxxx

1. EN
2. IN
3. GND (TAB)
4. OUT
5. NC

*** Die Attach:
Conductive Epoxy**



AME 8865-BDVADJ

1. EN
2. IN
3. GND (TAB)
4. OUT
5. ADJ

*** Die Attach:
Conductive Epoxy**

■ Pin Configuration (Contd.)

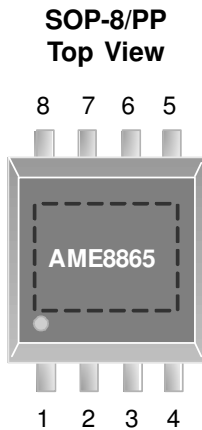
8 Pin

AME 8865-AZAADJ

1. ADJ
2. GND
3. GND
4. EN
5. IN
6. GND
7. GND
8. OUT

*** Die Attach:
Conductive Epoxy**

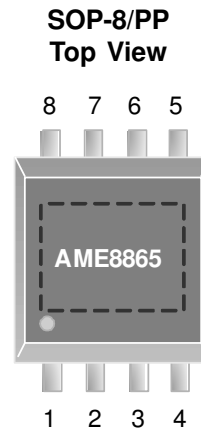
AME 8865-BZAADJ

1. EN
2. IN
3. OUT
4. ADJ
5. GND
6. GND
7. GND
8. GND

*** Die Attach:
Conductive Epoxy**

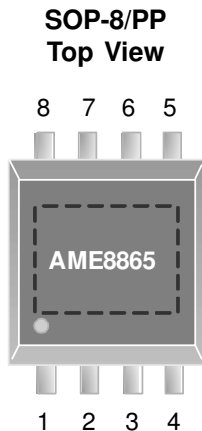
AME 8865-CZAxxx

1. NC
2. GND
3. GND
4. EN
5. IN
6. GND
7. GND
8. OUT

*** Die Attach:
Conductive Epoxy**

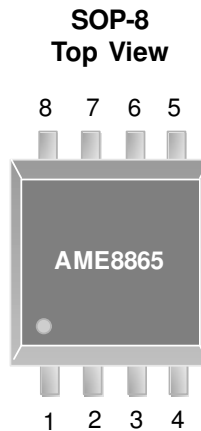
AME 8865-AHAxxx

1. EN
2. IN
3. OUT
4. ADJ
5. GND
6. GND
7. GND
8. GND

*** Die Attach:
Conductive Epoxy**

Note:
Connect exposed pad (heat sink on the back) to GND.

■ Pin Configuration
3 Pin

Pin Number								Pin Name	Pin Description
SOT-223		TO-252-2		TO-220-3		TO-263			
A	B	A	B	A	B	A	B		
1	3	1	3	1	3	1	3	IN	Input voltage pin; should be decoupled with 4.7 μ F or greater capacitor.
2	1	2	1	2	1	2	1	GND	Ground connection pin.
3	2	3	2	3	2	3	2	OUT	LDO voltage regulator output pin; should be decoupled with a 4.7 μ F or greater value low ESR ceramic capacitor.

5 Pin

Pin Number		Pin Name	Pin Description
TO-263-5			
A	B		
2	2	IN	Input voltage pin; should be decoupled with 4.7 μ F or greater capacitor.
1	1	EN	Enable pin, Active "high". When pulled "low", the PMOS pass transistor turns off, current consuming less than 1 μ A. When EN pin float outside, it's weakly pulled high from internal MOS.
3	3	GND	Ground connection pin.
4	4	OUT	LDO voltage regulator output pin; should be decoupled with a 4.7 μ F or greater value low ESR ceramic capacitor.
5	N/A	NC	No connection.
N/A	5	ADJ	Feedback output voltage for adjustable device.

■ Pin Configuration (Contd.)

8 Pin

Pin Number				Pin Name	Pin Description
SOP-8/PP			SOP-8		
A	B	C	A		
5	2	5	2	IN	Input voltage pin; should be decoupled with 4.7 μ F or greater capacitor.
4	1	4	1	EN	Enable pin, Active "high". When pulled "low", the PMOS pass transistor turns off, current consuming less than 1 μ A. When EN pin float outside, it's weakly pulled high form internal MOS.
2 3 6 7	5 6 7 8	2 3 6 7	5 6 7 8	GND	Ground connection pin.
8	3	8	3	OUT	LDO voltage regulator output pin; should be decoupled with a 4.7 μ F or greater value low ESR ceramic capacitor.
1	4	1	4	ADJ	Feedback output voltage for adjustable device.

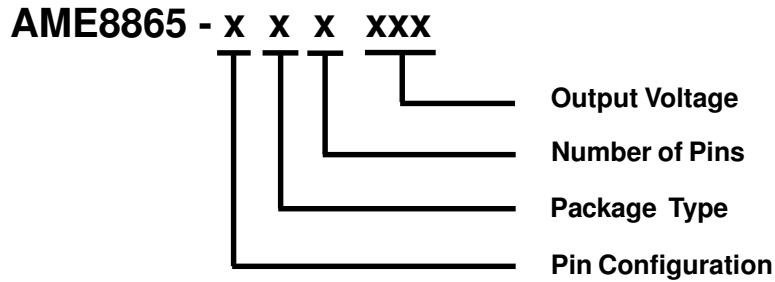
■ Ordering Information

Pin Configuration	Package Type	Number of Pins	Output Voltage
A 1. IN <small>(SOT-223)</small> 2. GND <small>(TO-252-2)</small> 3. OUT <small>(TO-220-3)</small> <small>(TO-263-3)</small> <small>(TO263-2)</small>	B: TO-220 C: TO-252 D: TO-263 G: SOT-223 H: SOP-8	A: 8 S: 2 T: 3 V: 5	100: 1.0V 120: 1.2V 150: 1.5V 180: 1.8V 250: 2.5V 300: 3.0V 330: 3.3V ADJ: Adjustable
B 1. GND <small>(SOT-223)</small> 2. OUT <small>(TO-252-2)</small> 3. IN <small>(TO-220-3)</small> <small>(TO-263-3)</small> <small>(TO-263-2)</small>			
A 1. EN <small>(TO-263-5)</small> 2. IN 3. GND 4. OUT 5. NC			
B 1. EN <small>(TO-263-5)</small> 2. IN 3. GND 4. OUT 5. ADJ			
A 1. EN <small>(SOP-8)</small> 2. IN 3. OUT 4. ADJ 5. GND 6. GND 7. GND 8. GND			

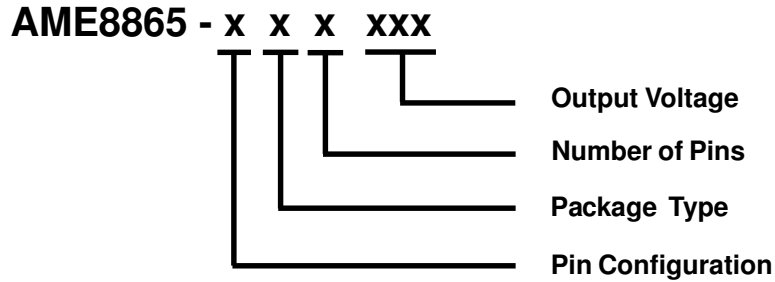
■ Ordering Information (Contd.)

Pin Configuration	Package Type	Number of Pins	Output Voltage
A (SOP-8/PP) 1. NC 2. GND 3. GND 4. EN 5. IN 6. GND 7. GND 8. OUT	Z: SOP-8/PP	A: 8	100: 1.0V 120: 1.2V 150: 1.5V 180: 1.8V 250: 2.5V 300: 3.0V 330: 3.3V ADJ: Adjustable
B (SOP-8/PP) 1. EN 2. IN 3. OUT 4. ADJ 5. GND 6. GND 7. GND 8. GND			
C (SOP-8/PP) 1. NC 2. GND 3. GND 4. EN 5. IN 6. GND 7. GND 8. OUT			

■ Absolute Maximum Ratings

Parameter	Maximum	Unit
Input Voltage	-0.3 to 6	V
Output Voltage	GND - 0.3 to $V_{IN} + 0.3$	V
Electrostatic Discharge (HBM)	2	kV
Electrostatic Discharge (MM)	200	V
Electrostatic Discharge (CDM)	1000	
Junction Temperature	150	°C
Storage Temperature Range	200	

■ Recommended Operating Conditions

Parameter	Symbol	Rating	Unit
Power Input Voltage	V_{IN}	2.5 to 5.5	V
Ambient Temperature Range	T_A	- 40 to +85	°C
Junction Temperature Range	T_J	- 40 to +125	°C

■ Thermal Information

Parameter	Package	Die Attach	Symbol	Maximum	Unit
Thermal Resistance* (Junction to Case)	SOT-223	Conductive Epoxy	θ_{JC}	25	°C / W
		Non-Conductive Epoxy		31	
	TO-252-2	Conductive Epoxy		5	
		Non-Conductive Epoxy		30	
	TO-220-3	Conductive Epoxy		6	
		Non-Conductive Epoxy		24	
	TO-263-2 TO-263-3 TO-263-5	Conductive Epoxy		5	
	TO-263-2 TO-263-3	Non-Conductive Epoxy		27	
	SOP-8/PP	Conductive Epoxy		19	
SOP-8	Conductive Epoxy	60			
Thermal Resistance (Junction to Ambient)	SOT-223	Conductive Epoxy	θ_{JA}	120	°C / W
		Non-Conductive Epoxy		135	
	TO-252-2	Conductive Epoxy		90	
		Non-Conductive Epoxy		140	
	TO-220-3	Conductive Epoxy		55	
		Non-Conductive Epoxy		80	
	TO-263-2 TO-263-3 TO-263-5	Conductive Epoxy		80	
	TO-263-2 TO-263-3	Non-Conductive Epoxy		100	
	SOP-8/PP	Conductive Epoxy		84	
SOP-8	Conductive Epoxy	150			

■ Thermal Information (Contd.)

Parameter	Package	Die Attach	Symbol	Maximum	Unit
Internal Power Dissipation	SOT-223	Conductive Epoxy	P _D	900	mW
		Non-Conductive Epoxy		800	
	TO-252-2	Conductive Epoxy		1200	
		Non-Conductive Epoxy		1000	
	TO-220-3	Conductive Epoxy		2200	
		Non-Conductive Epoxy		1600	
	TO-263-2 TO-263-3 TO-263-5	Conductive Epoxy		1700	
	TO-263-2 TO-263-3	Non-Conductive Epoxy		1400	
	SOP-8/PP	Conductive Epoxy		1450	
	SOP-8	Conductive Epoxy		810	
Lead Temperature (soldering 10 sec)**				260	°C

* Measure θ_{jc} on backside center of tab

** MIL-STD-202G210F

■ Electrical Specifications

Typical values $V_{IN}=V_{OUT}+1V$ (for $V_{OUT}<2V$ $V_{IN}=2.5V$) with typical $T_A=25^\circ C$, unless otherwise specified.

Parameter	Symbol	Test Condition	Min	Typ	Max	Units
Input Voltage	V_{IN}		2.5		5.5	V
Output Accuracy (For Fixed Version)	$V_{OUT,ACC}$		-2		2	%
ADJ Reference Voltage	V_{ADJ}		0.784	0.8	0.816	V
ADJ Input Bias Current	I_{ADJ}	$V_{IN}=5V, V_{ADJ}=1.0V$			1	μA
Output Voltage Range (For ADJ Version)	V_{OUT}		0.8		4.5	V
Dropout Voltage (Note1)	V_{DROP}	$I_{OUT}=1.5A, 1.2V \leq V_{OUT(NOM)} \leq 1.8V$		600	Note2	mV
		$I_{OUT}=1.5A, 1.8V < V_{OUT(NOM)} \leq 2.5V$		500		
		$I_{OUT}=1.5A, 2.5V < V_{OUT(NOM)}$		400		
Output Current	I_{OUT}		1.5			A
Quiescent Current (For Fixed Version)	I_Q	$I_{OUT}=0mA$		500		μA
Line Regulation	REG_{LINE}	$V_{IN,MIN} \leq V_{IN} \leq V_{IN,MIN}+0.7V$ 10mA		0.25		%/V
Load Regulation	REG_{LOAD}	$V_{IN}=V_{OUT}+1V$ $10mA \leq I_{OUT} \leq 1.5A$		0.8	2	%/A
Power Supply Rejection Ratio	PSRR	$F=120Hz, I_{OUT}=100mA, C_{OUT}=4.7\mu F$		60		dB
Output Current Limit	I_{LIM}	$V_{OUT} = 0.9 \times V_{OUT(NOM)}$	1.6			A
Short Circuit Current	I_{SC}	$V_{IN} = V_{OUT(NOM)}+1V, V_{OUT} < 0.4V$		900		mA
Thermal Shutdown Temperature	T_{SHDN}	Shutdown, temperature increasing		150		$^\circ C$
		Restore, temperature decreasing		130		
EN Pin Voltage High	$V_{EH,HI}$	$V_{IN(MIN)} \leq V_{IN} \leq 5.5V$	1.4		V_{IN}	V
EN Pin Voltage Low	$V_{EN,LO}$	$V_{IN(MIN)} \leq V_{IN} \leq 5.5V$			0.4	V
Enable Input Bias Current	I_{EN}	$V_{EN} = V_{IN}$		0.1	1.0	μA
		$V_{EN} = 0V$		0.1	1.0	
Shutdown Current	I_{SHDN}	$V_{EN}=0V$			1.5	μA

Note 1. Dropout Voltage is measured at $V_{OUT} = V_{OUT(NOM)} \times 98\%$

Note 2. $V_{IN(MIN)} = V_{DROP} + V_{OUT(NOM)}$ or $V_{IN(MIN)} = 2.5V$ whichever is greater

■ Detailed Description

The AME8865 is low-dropout; low quiescent current linear regulator designed for motherboard, notebook and LCD monitor applications. The output voltage range from 0.8V to 4.5V, and can drive 1.5A loading current.

Capacitor Selection and Regulator Stability

Use 4.7 μ F for input capacitor and 4.7 μ F or greater for output capacitor on the AME8865. Larger input capacitor value and low ESR provide better supply noise rejection and improve line transient response. To reduce output noise and load transient response, use output capacitor greater than 4.7 μ F. In addition, AME8865 can prevent output voltage overshoot at power-on or enabled through the EN/ENB pin.

Adjustable Version

The adjustable version uses external feedback resistors to generate an output voltage anywhere from 1.0V to 5.0V. By the equation:

$$V_{OUT} = V_{ADJ} \left(1 + \frac{R1}{R2}\right)$$

Feedback resistors R1 and R2 should be high enough to keep quiescent current low, but increasing R1 + R2 will reduce stability. In general, R1 and R2 in the 10' s of K Ω will produce adequate stability, given reasonable layout precautions. To improve stability characteristics, keep parasites on the ADJ pin to a minimum, and lower R1 and R2 values.

Calculating the Maximum Output Power

The maximum output power of the AME8865 is limited by the maximum power dissipation of the package. By calculation the power dissipation of the package as a function of the input voltage, output voltage and output current, the maximum input voltage can be obtained. The maximum power dissipation should not exceed the package's maximum power rating.

$$P_{MAX} = (V_{IN(MAX)} - V_{OUT}) \times I_{OUT}$$

Where: $V_{IN(MAX)}$ = maximum input voltage

P_{MAX} = maximum power dissipation of the package

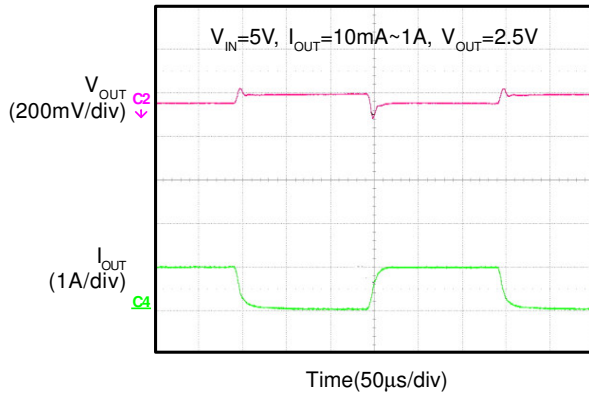
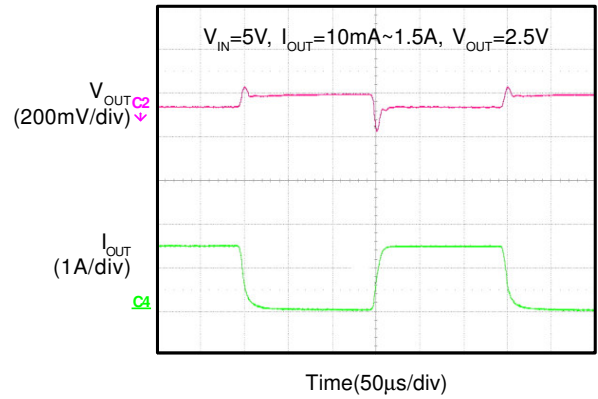
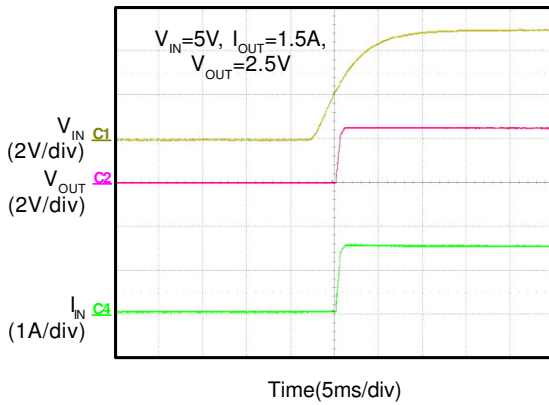
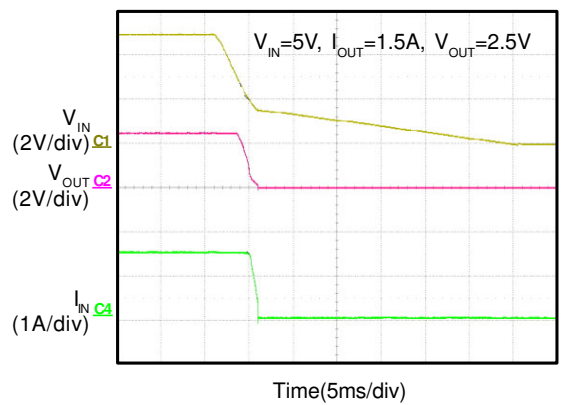
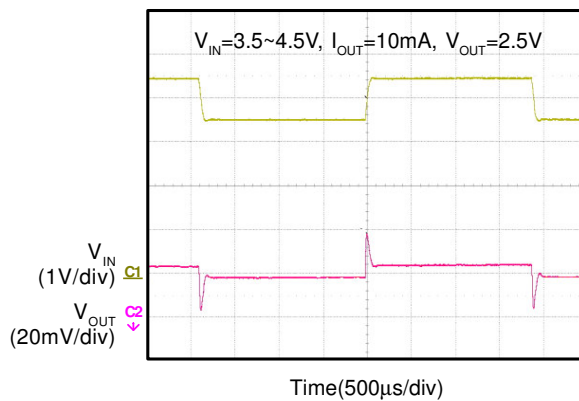
■ Characterization Curve
Load Transient Response

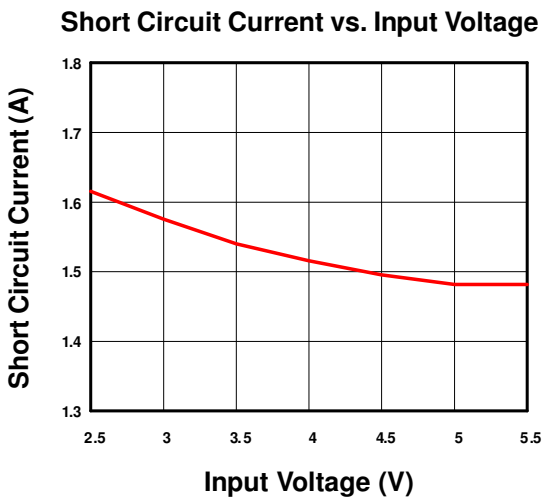
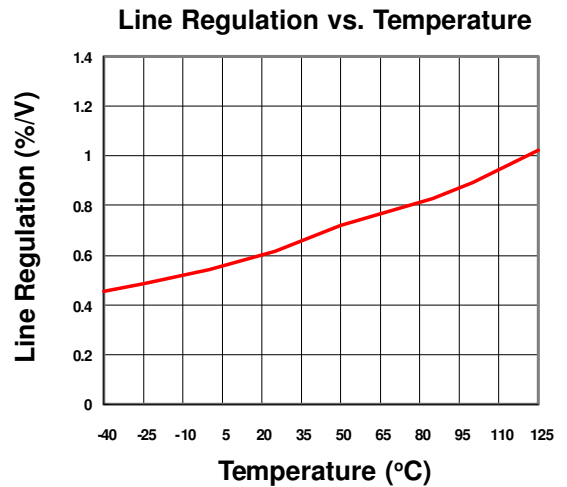
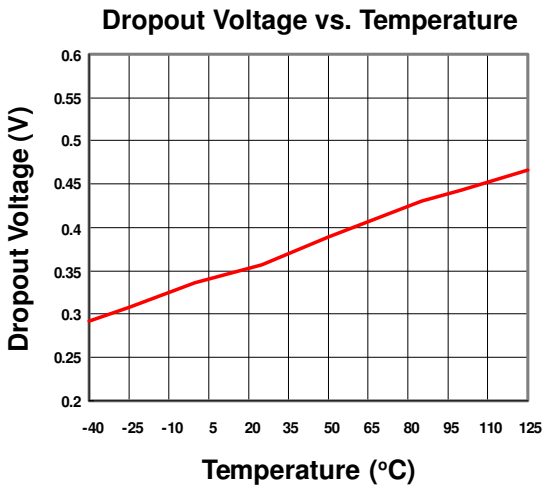
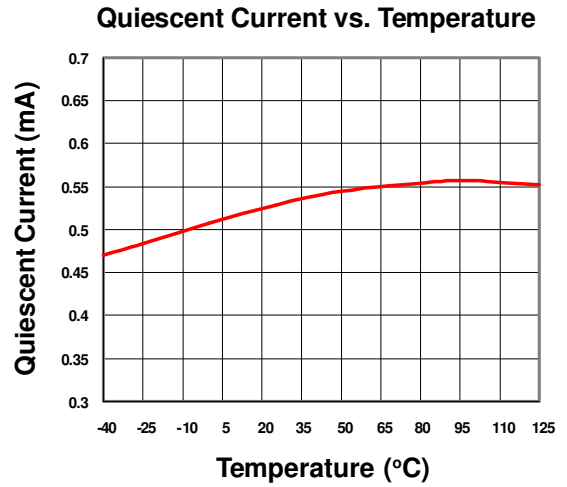
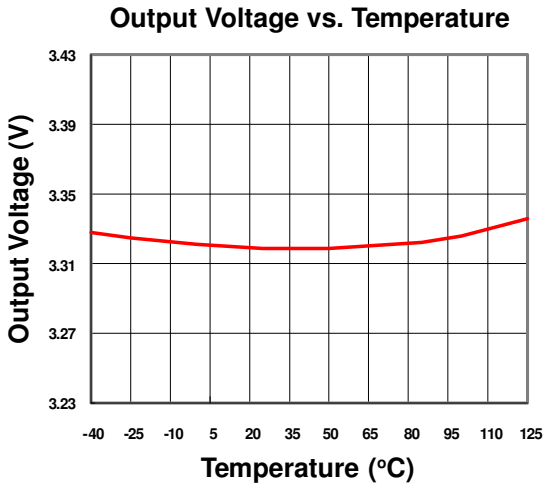
Load Transient Response

Power On from V_{IN}

Power Off from V_{IN}

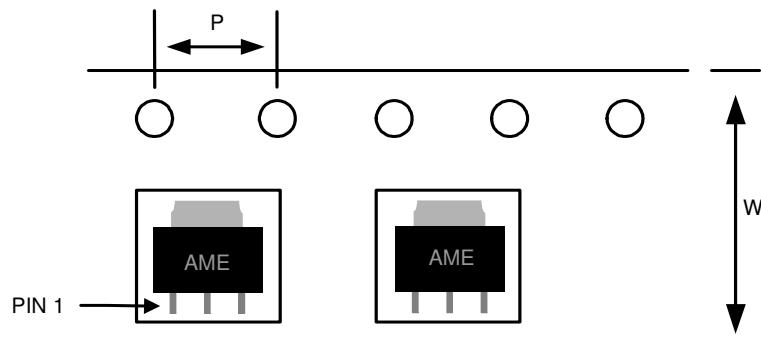
Line Transient Response

■ Characterization Curve

■ Date Code Rule

Month Code	
1: January	7: July
2: February	8: August
3: March	9: September
4: April	A: October
5: May	B: November
6: June	C: December

■ Tape and Reel Dimension
SOT-223

Carrier Tape, Number of Components Per Reel and Reel Size

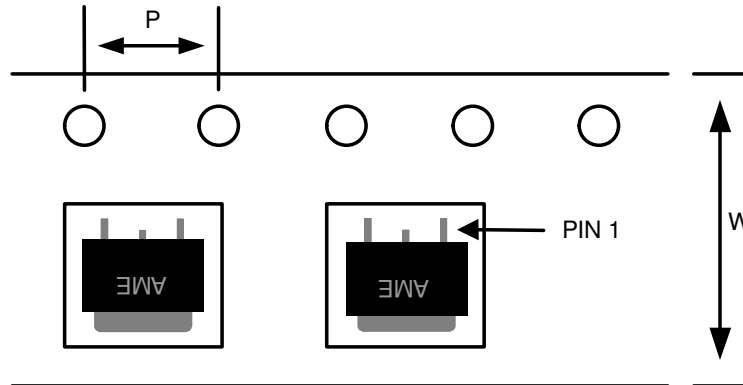
Package	Carrier Width (W)	Pitch (P)	Part Per Full Reel	Reel Size
SOT-223	12.0±0.1 mm	4.0±0.1 mm	2500pcs	330±1 mm

■ Tape and Reel Dimension (Contd.)
TO-252-2

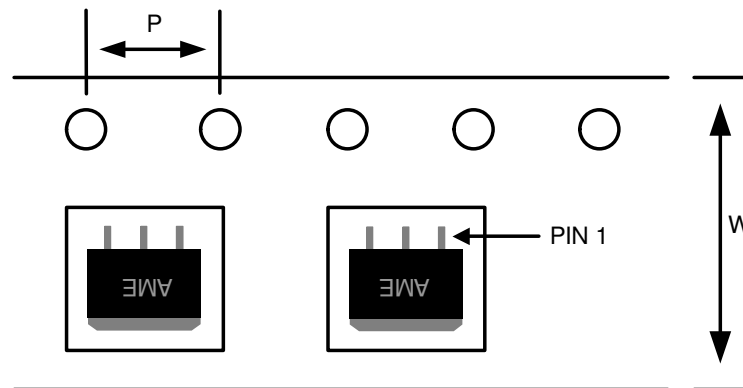
Carrier Tape, Number of Components Per Reel and Reel Size

Package	Carrier Width (W)	Pitch (P)	Part Per Full Reel	Reel Size
TO-252-2	16.0±0.1 mm	4.0±0.1 mm	2500pcs	330±1 mm

TO-263-3

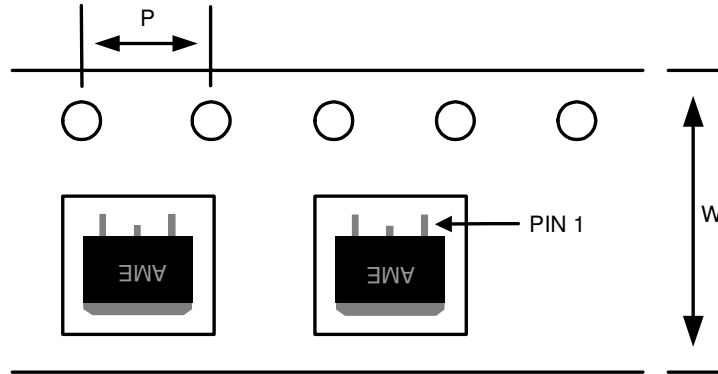
Carrier Tape, Number of Components Per Reel and Reel Size

Package	Carrier Width (W)	Pitch (P)	Part Per Full Reel	Reel Size
TO-263-3	24.0±0.1 mm	4.0±0.1 mm	800pcs	330±1 mm

■ Tape and Reel Dimension (Contd.)
TO-263-2

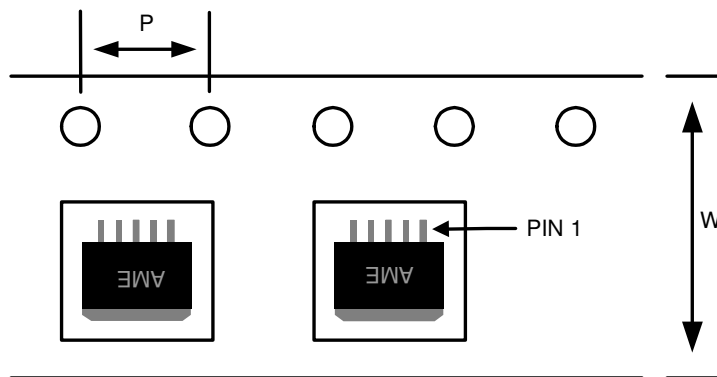
Carrier Tape, Number of Components Per Reel and Reel Size

Package	Carrier Width (W)	Pitch (P)	Part Per Full Reel	Reel Size
TO-263-2	24.0±0.1 mm	4.0±0.1 mm	800pcs	330±1 mm

TO-263-5

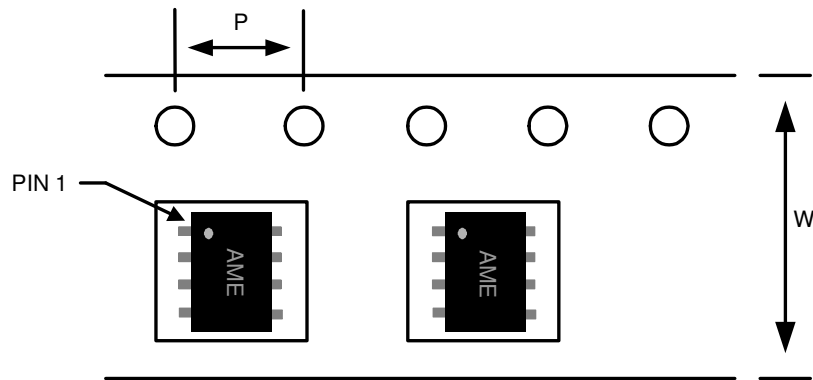
Carrier Tape, Number of Components Per Reel and Reel Size

Package	Carrier Width (W)	Pitch (P)	Part Per Full Reel	Reel Size
TO-263-5	24.0±0.1 mm	4.0±0.1 mm	800pcs	330±1 mm

■ Tape and Reel Dimension (Contd.)
SOP-8/PP

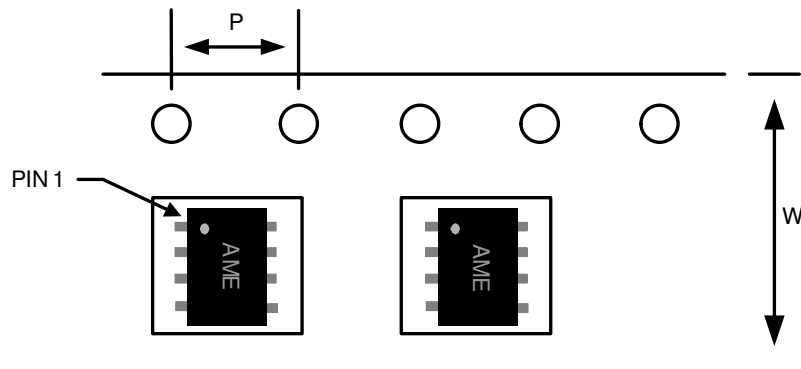
Carrier Tape, Number of Components Per Reel and Reel Size

Package	Carrier Width (W)	Pitch (P)	Part Per Full Reel	Reel Size
SOP-8/PP	12.0±0.1 mm	4.0±0.1 mm	2500pcs	330±1 mm

SOP-8

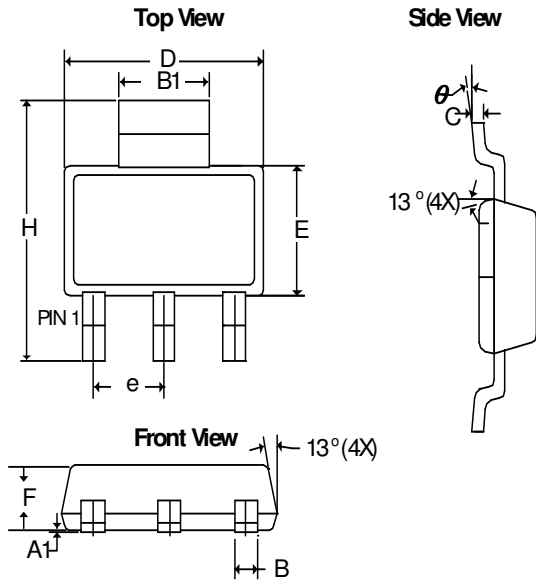
Carrier Tape, Number of Components Per Reel and Reel Size

Package	Carrier Width (W)	Pitch (P)	Part Per Full Reel	Reel Size
SOP-8	12.0±0.1 mm	4.0±0.1 mm	2500pcs	330±1 mm

■ Package Dimension
SOT-223

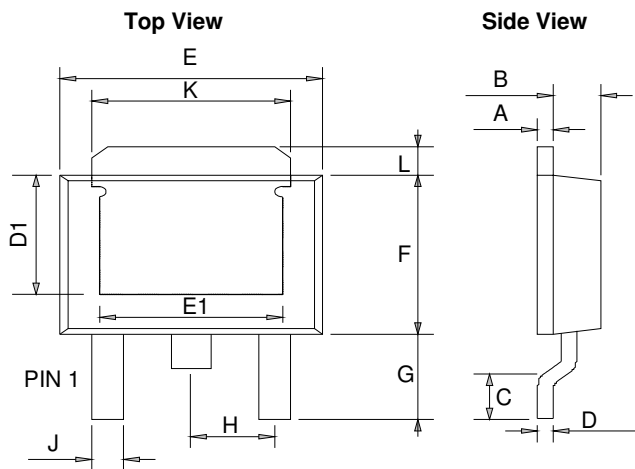
SYMBOLS	MILLIMETERS		INCHES	
	MIN	MAX	MIN	MAX
A ₁	0.01	0.10	0.0004	0.0039
B	0.60	0.84	0.0236	0.0330
B ₁	2.90	3.15	0.1140	0.1240
C	0.24	0.38	0.0094	0.0150
D	6.20	6.71	0.2441	0.2640
E	3.30	3.71	0.1299	0.1460
e	2.30 BSC		0.0906 BSC	
F	1.40	1.80	0.0551	0.0709
H	6.70	7.30	0.2638	0.2874
θ	0°	10°	0°	10°

TO-252-2

SYMBOLS	MILLIMETERS		INCHES	
	MIN	MAX	MIN	MAX
A	0.43	0.89	0.0169	0.0350
B	1.60	1.95	0.0630	0.0768
C	0.51	1.78	0.0200	0.0701
D	0.43	0.60	0.0169	0.0236
E	6.35	6.80	0.2500	0.2677
F	5.36	6.22	0.2110	0.2450
G	2.20	3.00	0.0866	0.1181
H	-	* 2.30	-	*0.0906
J	0.50	0.97	0.0197	0.0380
K	4.95	5.50	0.1950	0.2165
L	0.90	1.65	0.0354	0.0650
D ₁	3.80 REF		0.1496 REF	
E ₁	3.81	5.10	0.1500	0.2008

*: Typical Value

Notes:

- Controlling dimension: Millimeters.
- Maximum lead thickness includes lead finish thickness. Minimum lead thickness is the minimum thickness of base material.

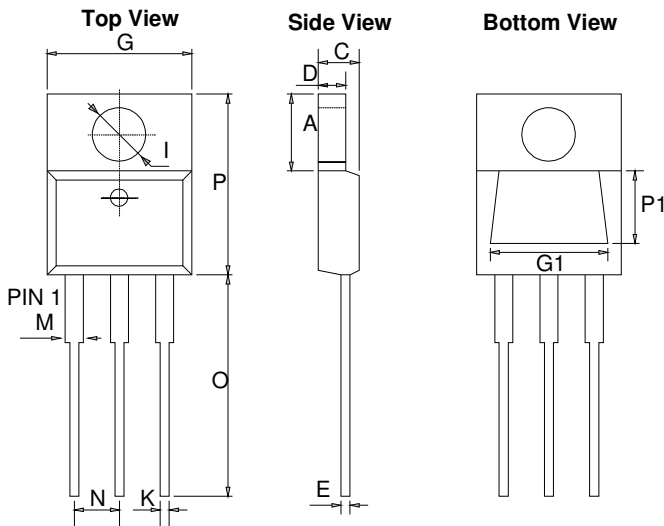
■ Package Dimension (Contd.)
TO-220-3

SYMBOLS	MILLIMETERS		INCHES	
	MIN	MAX	MIN	MAX
A	5.58	7.49	0.2197	0.2949
C	2.03	4.83	0.0799	0.1902
D	0.50	1.45	0.0197	0.0571
E	0.30	1.15	0.0118	0.0453
G	9.65	10.67	0.3799	0.4201
I	3.53	4.09	0.1390	0.1610
K	0.50	1.15	0.0197	0.0453
M	1.14	1.78	0.0449	0.0701
N	2.28	2.80	0.0898	0.1102
O	12.70	14.74	0.5000	0.5803
P	14.22	16.51	0.5598	0.6500
P1	5.00	5.70	0.1969	0.2244
G1	7.30	8.05	0.2874	0.3169

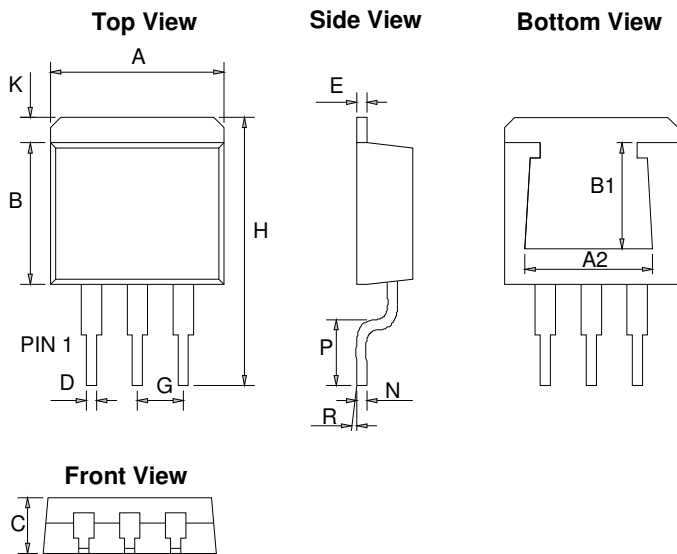
TO-263-3

SYMBOLS	MILLIMETERS		INCHES	
	MIN	MAX	MIN	MAX
A	9.65	10.67	0.380	0.420
B	8.28	9.66	0.326	0.380
C	4.06	4.83	0.160	0.190
D	0.50	1.36	0.020	0.054
E	1.14	1.45	0.045	0.057
G	2.54		0.100	
H	14.60	15.875	0.5748	0.625
K	0.99	2.93	0.03898	0.11535
N	0.31		0.012	
P	2.28	2.80	0.08976	0.11024
R	0°	8°	0°	8°
B1	5.00	5.70	0.197	0.224
A2	7.30	8.05	0.287	0.317

*: Typical Value

Notes:

1. Controlling dimension: Millimeters.

2. Maximum lead thickness includes lead finish thickness. Minimum lead thickness is the minimum thickness of base material.

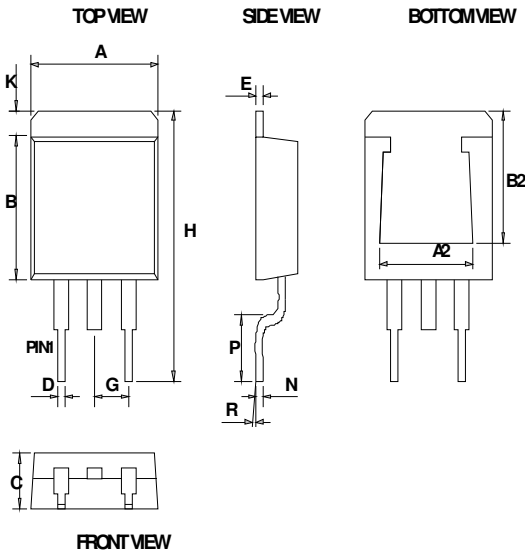
■ Package Dimension (Contd.)
TO-263-2

SYMBOLS	MILLIMETERS		INCHES	
	MIN	MAX	MIN	MAX
A	9.65	10.42	0.380	0.410
B	8.28	9.66	0.326	0.380
C	4.06	4.83	0.160	0.190
D	0.50	1.36	0.020	0.054
E	1.14	1.45	0.045	0.057
G	*2.54		*0.100	
H	14.60	15.80	0.575	0.622
K	0.99	2.93	0.039	0.115
N	0.38 REF		0.015 REF	
P	2.28	2.80	0.090	0.110
R	0°	8°	0°	8°
B2	6.30	8.20	0.248	0.323
A2	7.30	8.95	0.287	0.352

*: Typical Value

Notes:

1. Controlling dimension: Millimeters
2. Maximum lead thickness includes lead finish thickness Minimum lead thickness is the minimum thickness of base material.

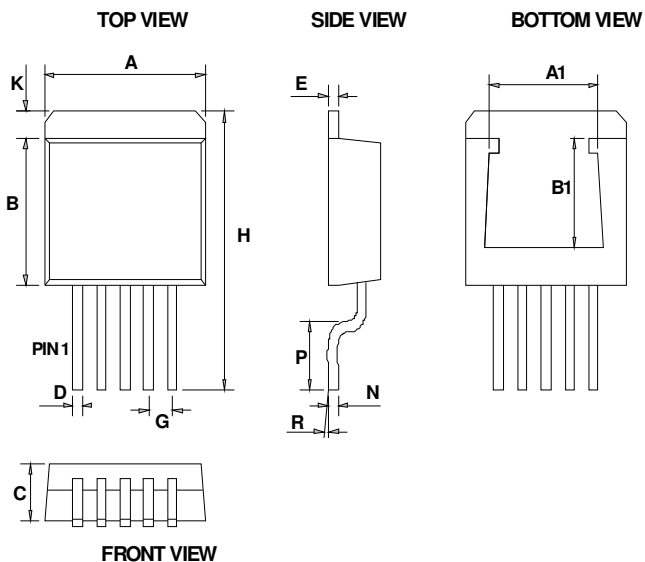
TO-263-5

SYMBOLS	MILLIMETERS		INCHES	
	MIN	MAX	MIN	MAX
A	9.800	10.668	0.386	0.420
B	8.200	9.169	0.323	0.361
C	4.310	4.800	0.170	0.189
D	0.660	0.910	0.026	0.036
E	1.140	1.450	0.045	0.057
G	1.70 REF		0.067 REF	
H	14.600	15.875	0.575	0.625
K	1.143	1.760	0.045	0.069
N	0.310	0.580	0.012	0.023
P	2.280	2.800	0.090	0.110
R	0°	8°	0°	8°
A1	7.500	7.700	0.295	0.303
B1	5.800	6.450	0.228	0.254

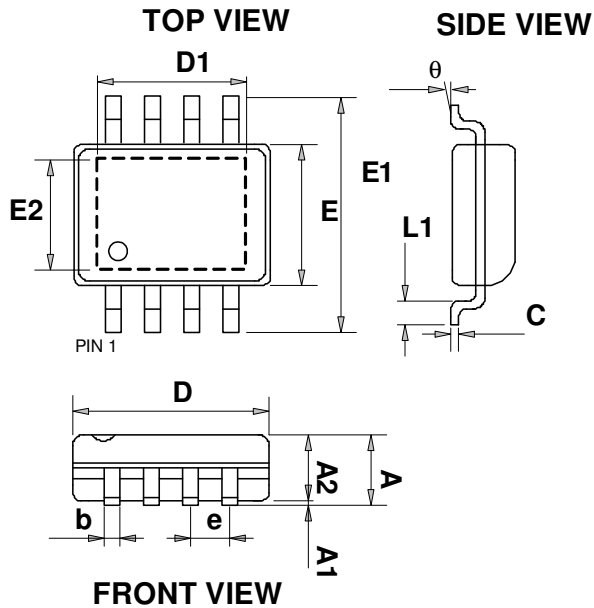
■ Package Dimension (Contd.)
SOP-8/PP

SYMBOLS	MILLIMETERS		INCHES	
	MIN	MAX	MIN	MAX
A	1.350	1.750	0.053	0.069
A1	0.000	0.250	0.000	0.010
A2	1.250	1.650	0.049	0.065
C	0.100	0.250	0.004	0.010
E	3.750	4.150	0.148	0.163
E1	5.700	6.300	0.224	0.248
L1	0.300	1.270	0.012	0.050
b	0.310	0.510	0.012	0.020
D	4.720	5.120	0.186	0.202
e	1.270 BSC		0.050 BSC	
θ	0°	8°	0°	8°
E2	2.050	2.600	0.081	0.102
D1	2.090	3.500	0.082	0.138

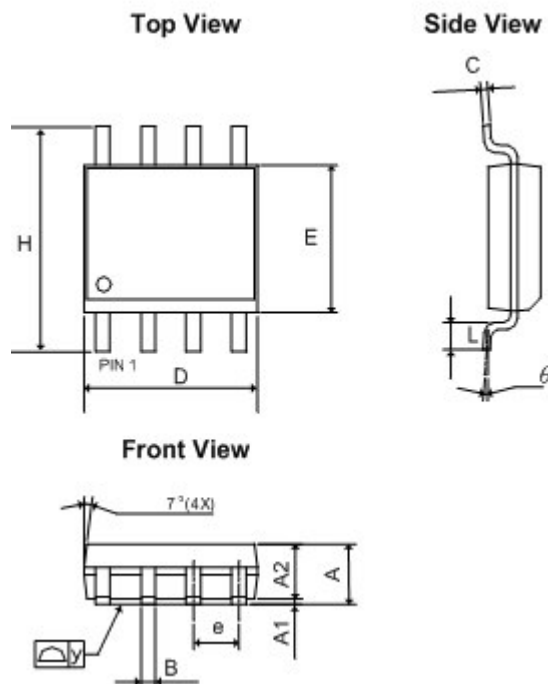
SOP-8

SYMBOLS	MILLIMETERS		INCHES	
	MIN	MAX	MIN	MAX
A	1.35	1.75	0.0531	0.0689
A ₁	0.10	0.30	0.0039	0.0118
A2	1.473 REF		0.0580 REF	
B	0.33	0.51	0.0130	0.0201
C	0.17	0.25	0.0067	0.0098
D	4.70	5.33	0.1850	0.2098
E	3.80	4.00	0.1496	0.1575
e	1.27 BSC		0.0500 BSC	
L	0.40	1.27	0.0157	0.0500
H	5.80	6.30	0.2283	0.2480
y	-	0.10	-	0.0039
θ	0°	8°	0°	8°



www.ame.com.tw
E-Mail: sales@ame.com.tw

Life Support Policy:

These products of AME, Inc. are not authorized for use as critical components in life-support devices or systems, without the express written approval of the president of AME, Inc.

AME, Inc. reserves the right to make changes in the circuitry and specifications of its devices and advises its customers to obtain the latest version of relevant information.

© AME, Inc. , September 2013
Document: A003B-DS8865-A.04

Corporate Headquarter
AME, Inc.

8F, 12 WenHu St., Nei-Hu
Taipei 114, Taiwan .
Tel: 886 2 2627-8687
Fax: 886 2 2659-2989