

# MAAM-009450

## Broadband CATV 3-Way Active Splitter with default loop-through Switch 50 - 1100 MHz

Rev. V3

### Features

- Always ON loop-thru path
- 3-Way Splitter
- 3.0 dB Gain
- +15 dBmV /Channel Input
- 3.8 dB Noise Figure
- Lead-Free 3 mm 12-Lead PQFN Package
- RoHS\* Compliant and 260°C Reflow Compatible

### Description

The MAAM-009450 CATV 3-way active splitter with the default loop-through path is a GaAs MMIC which exhibits low noise figure and distortion in a lead-free 3mm 12-lead PQFN plastic package. The design features 75  $\Omega$  inputs and outputs.

The MAAM-009450 is ideally suited for multi-tuner set top boxes, home gateways, and other broadband internet based applications.

The MAAM-009450 is fabricated using MACOM's E/D pHEMT process to realize default loop-through operation, low noise and low distortion. The process features full passivation for robust performance and reliability.

### Functional Schematic, Default On, Power Off

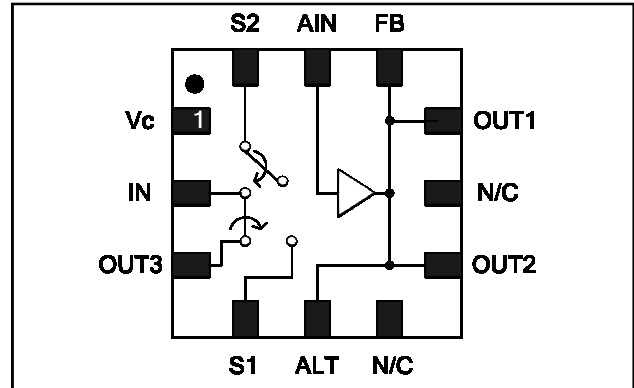

### Functional Schematic, Power On

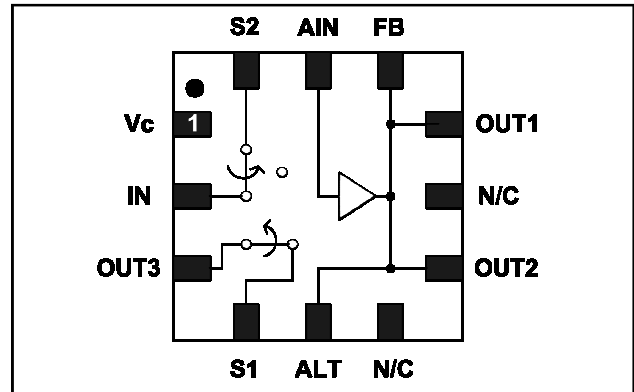

### Pin Configuration<sup>3</sup>

Pin No.	Pin Name	Description
1	V <sub>c</sub>	Voltage Control
2	IN	RF Input
3	OUT3	Loop thru Output
4	S1	Switch In
5	ALT	Alternate Output
6	N/C	No Connection
7	OUT2	RF Output 2
8	N/C	No Connection
9	OUT1	RF Output 1
10	FB/V <sub>DD</sub>	Amplifier Feedback / Drain Voltage
11	AIN	Amplifier Input
12	S2	Switch Output
13	Paddle	RF and DC Ground

3. The exposed pad centered on the package bottom must be connected to RF and DC ground.

### Ordering Information<sup>1,2</sup>

Part Number	Package
MAAM-009450-TR1000	1000 piece reel
MAAM-009450-TR3000	3000 piece reel
MAAM-009450-001SMB	Sample Test Board

1. Reference Application Note M513 for reel size information.
2. All sample boards include 5 loose parts.

\* Restrictions on Hazardous Substances, European Union Directive 2002/95/EC.

# MAAM-009450

## Broadband CATV 3-Way Active Splitter with default loop-through Switch 50 - 1100 MHz

Rev. V3

Electrical Specifications: Freq. = 1000 MHz,  $T_A = 25^\circ\text{C}$ ,  $Z_0 = 75 \Omega$

Parameter	Test Conditions	V <sub>DD</sub>	V <sub>C</sub>	Units	Min.	Typ.	Max.
Gain	IN to Out1, Out2 or Out3	5	3.3	dB	2.0	3.0	5.5
Insertion Loss	IN to Out3	0	0	dB	-	0.75	1.0
Noise Figure	IN to Out1, Out2 or Out3	5	3.3	dB	-	3.8	-
Gain Flatness	IN to Out1, Out2 or Out3	5	3.3	dB	-	1.0	-
Input Return Loss	Input	5	3.3	dB	-	12.5	-
Input Return Loss	Input	0	0	dB	-	12.5	-
Output Return Loss	Output	5	3.3	dB	-	10	-
Output Return Loss	Output	0	0	dB	-	10	-
Out to Out Isolation	Out1 to Out2 or Out3	5	3.3	dB	-	23	-
Out to Out Isolation	Out1 to Out2 or Out3	0	0	dB	-	35	-
CTB	132 Ch, +15 dBmV/Channel at the Input	5	3.3	dBc	-	-65	-
CSO	132 Ch, +15 dBmV/Channel at the Input	5	3.3	dBc	-	-65	-
Reverse Isolation	Out1 to In, Out2 to In	5	3.3	dB	-	31	-
Reverse Isolation	Out3 to In	5	3.3	dB	-	23	-
Reverse Isolation	Out1 to In, Out2 to In	0	0	dB	-	45	-
OIP2	500 MHz, 2-tone, 6 MHz spacing, -10 dBm Pout	5	3.3/0	dBm	-	42	-
OIP3	500 MHz, 2-tone, 6 MHz spacing, -10 dBm Pout	5	3.3/0	dBm	-	20	-
P1dB	500 MHz	5	3.3	dBm	-	7	-
P1dB	500 MHz	5	0	dBm	-	25	-
I <sub>DD</sub>		5	3.3	mA	-	100	130
I <sub>C</sub>		5	3.3	μA	-	205	250

4. The unpowered state is the same as V<sub>control</sub> = 0 V

# MAAM-009450

## Broadband CATV 3-Way Active Splitter with default loop-through Switch 50 - 1100 MHz

Rev. V3

### Absolute Maximum Ratings<sup>5,6,7</sup>

Parameter	Absolute Maximum
Max Input Power	+5 dBm
V <sub>DD</sub>	+10.0 V
V <sub>CONTROL</sub>	+8.5 V
Operating Temperature	-40°C to +85°C
Junction Temperature <sup>8</sup>	+150°C
Storage Temperature	-65°C to +150°C

- Exceeding any one or combination of these limits may cause permanent damage to this device.
- M/A-COM does not recommend sustained operation near these survivability limits.
- These operating conditions will ensure MTTF > 1 x 10<sup>6</sup> hours.
- Junction Temperature (T<sub>J</sub>) = T<sub>A</sub> + Θ<sub>Jc</sub> \* (V \* I)  
Typical thermal resistance (Θ<sub>Jc</sub>) = 73 °C/W.  
a) For T<sub>A</sub> = 25°C,  
T<sub>J</sub> = 72 °C @ 5.0 V, 130 mA  
b) For T<sub>A</sub> = 85°C,  
T<sub>J</sub> = 129 °C @ 5.0 V, 120 mA

### Truth Table<sup>9</sup>

V <sub>DD</sub>	V <sub>CONTROL</sub>	IN - OUT1	IN - OUT2	IN - OUT3
1	1	On	On	On
0	0	Off	Off	On

9. Logic "1" for V<sub>DD</sub> = +5 volts and V<sub>CONTROL</sub> = +3.3 volts typical.

### Handling Procedures

Please observe the following precautions to avoid damage:

### Static Sensitivity

Gallium Arsenide Integrated Circuits are sensitive to electrostatic discharge (ESD) and can be damaged by static electricity. Proper ESD control techniques should be used when handling these devices. An external protection circuit using an inexpensive anti-parallel diode pair can be used to protect the IC.

Please reference application note AN3028 on <http://www.macomtech.com> for further detail.

### Schematics Including Off-Chip Components<sup>10</sup>

#### Power On Condition

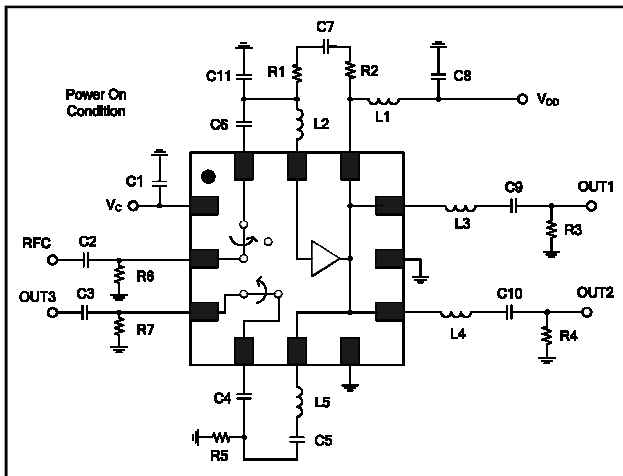

#### Power Off, Default on Condition

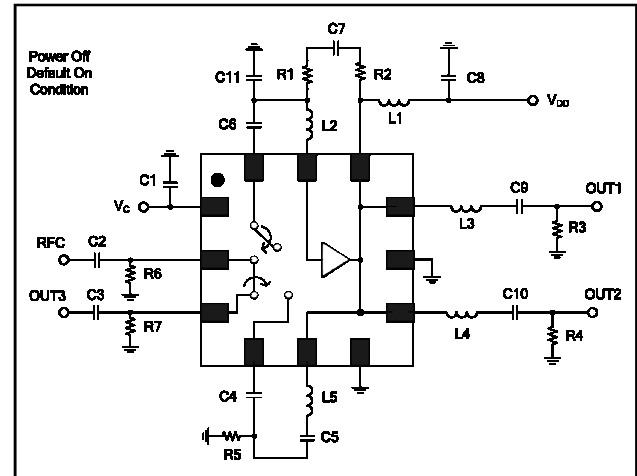

10. The exposed pad centered on the package bottom must be connected to ground for RF, DC and thermal considerations.

# MAAM-009450

**Broadband CATV 3-Way Active Splitter with default loop-through Switch**  
**50 - 1100 MHz**

Rev. V3

## Recommended PCB

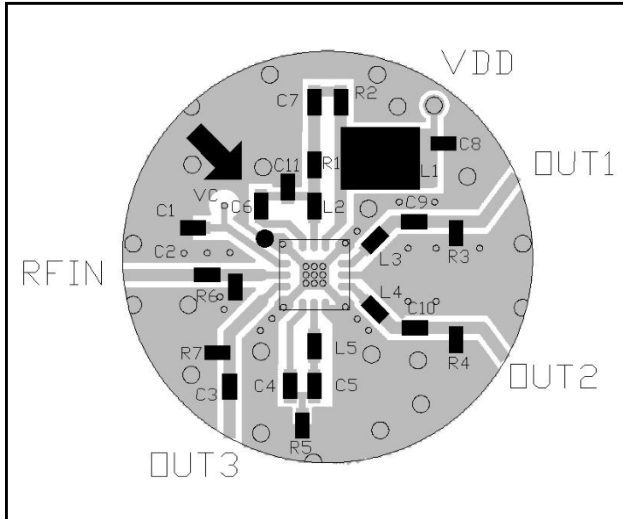

## PCB Land Pattern

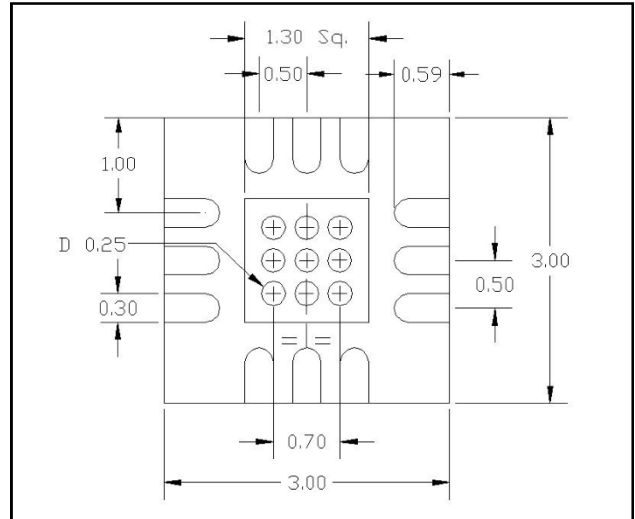

## Block Diagram RF Signal Flow

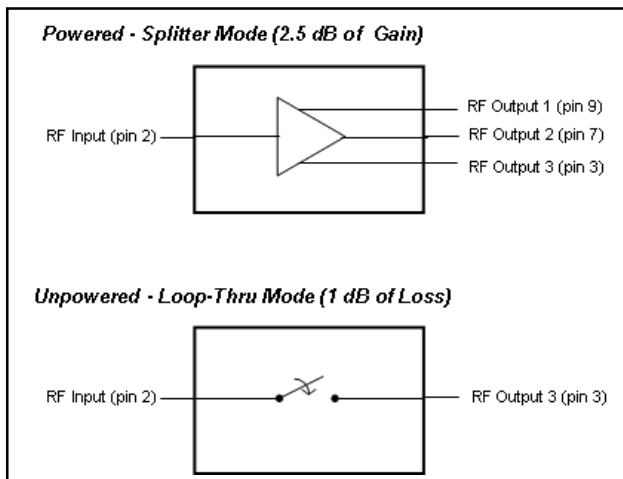

## Off-Chip Component Values

Component	Value	Package
C1 - C10	0.01 $\mu$ F	0402
C11	1.0 pF	0402
L1 <sup>11</sup>	1 $\mu$ H	1210
L2 - L5	7.5 nH	0402
R1, R2	300 $\Omega$	0402
R3, R4	180 $\Omega$	0402
R5	250 $\Omega$	0402
R6, R7	22 k $\Omega$	0402

11. L1 supplied from EPCOS, part number B82422A1102K100

# MAAM-009450

## Broadband CATV 3-Way Active Splitter with default loop-through Switch 50 - 1100 MHz

Rev. V3

### Typical Performance Curves

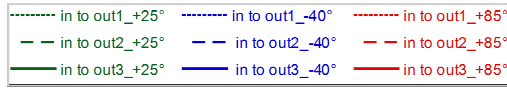

Gain

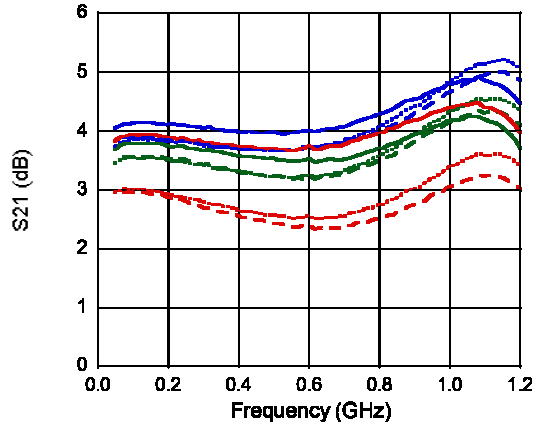

Gain

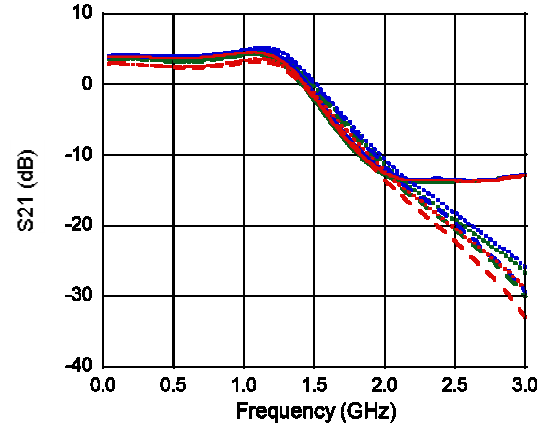

Input Return Loss (power on)

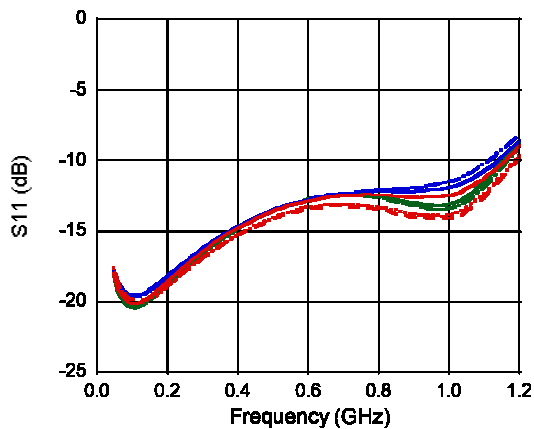

Input Return Loss (power off)

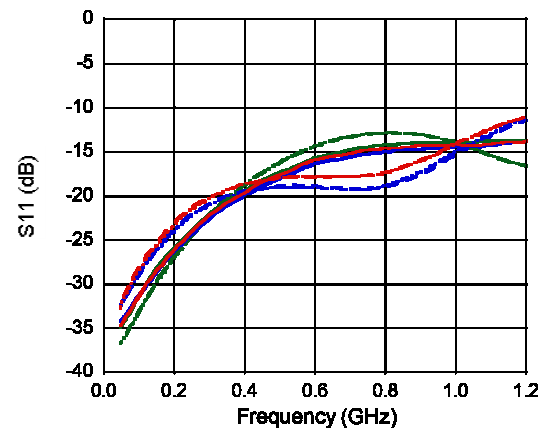

Output Return Loss (power on)

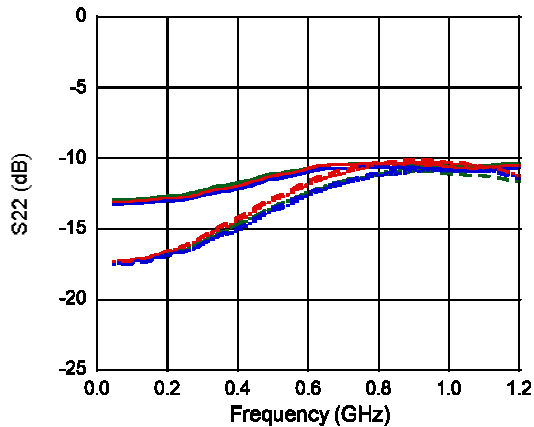

Output Return Loss (power off)

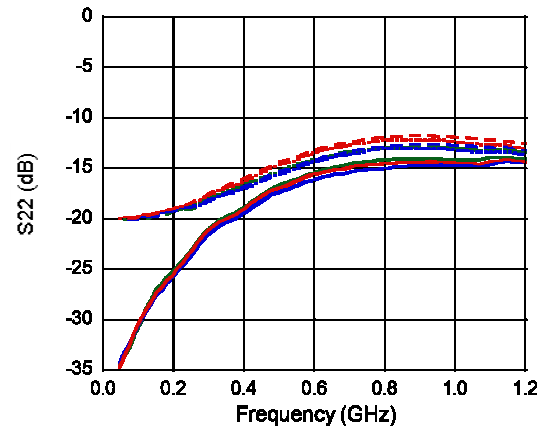

# MAAM-009450

## Broadband CATV 3-Way Active Splitter with default loop-through Switch 50 - 1100 MHz

Rev. V3

### Typical Performance Curves

Insertion Loss to 1 GHz (power off)

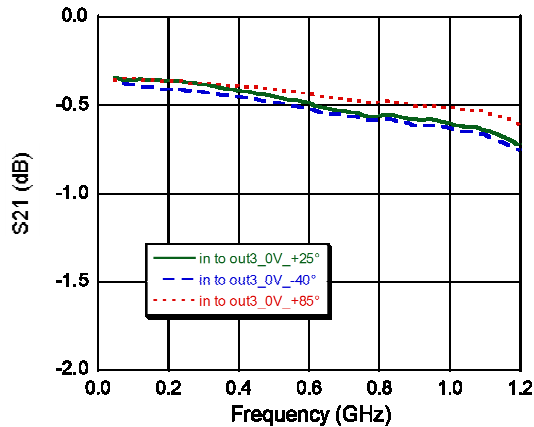

Insertion Loss to 3 GHz (power off)

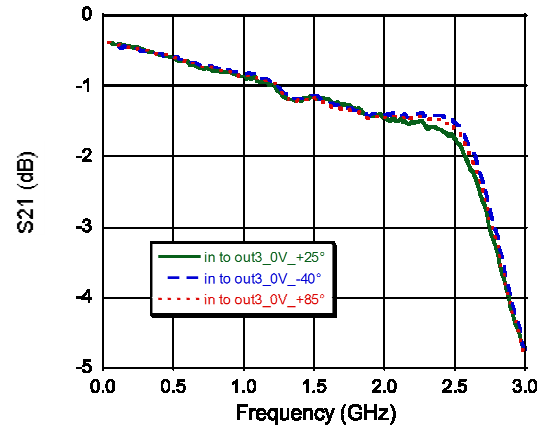

Reverse Isolation to 3 GHz (power on)

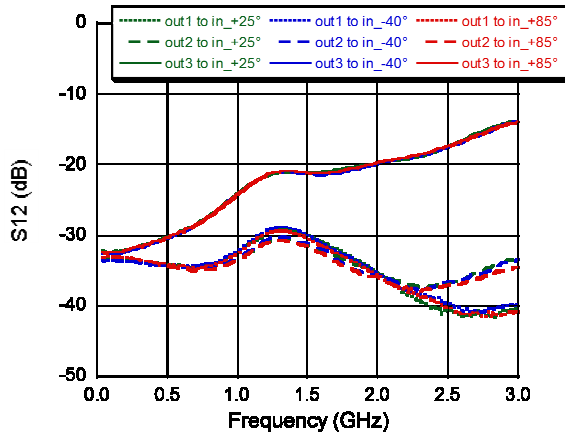

Reverse Isolation to 3 GHz (power off)

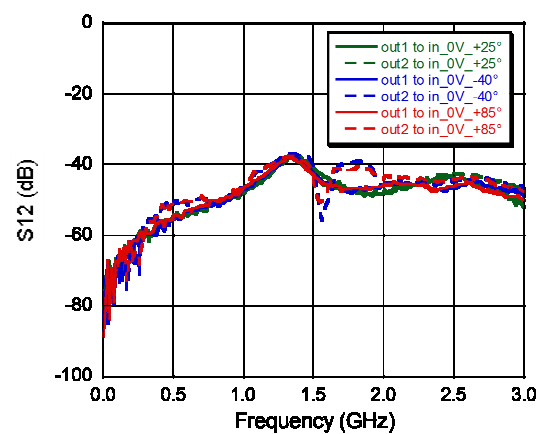

Noise Figure

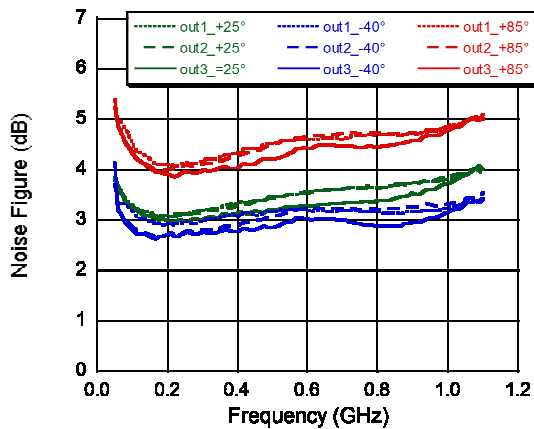

# MAAM-009450

## Broadband CATV 3-Way Active Splitter with default loop-through Switch 50 - 1100 MHz

Rev. V3

### Typical Performance Curves

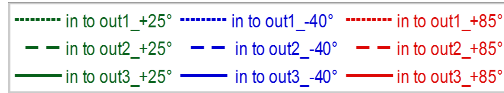

Out to Out Isolation to 1 GHz (power on)

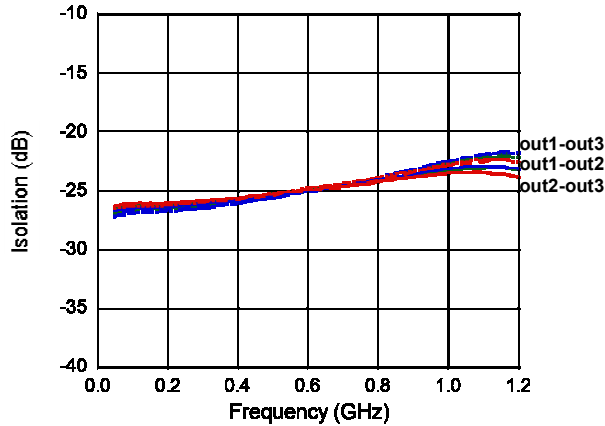

Out to Out Isolation to 3 GHz (power on)

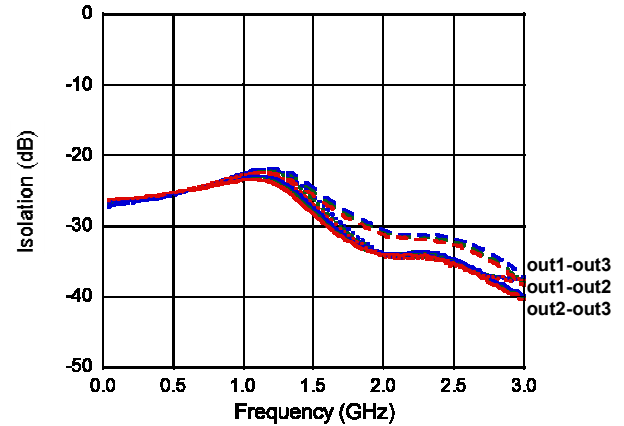

Out to Out Isolation to 1 GHz (power off)

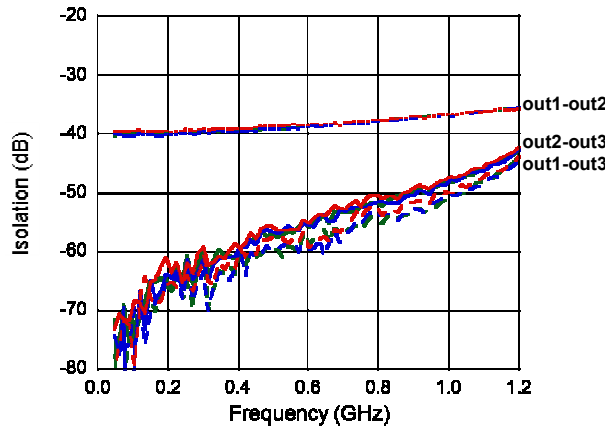

Out to Out Isolation to 3 GHz (power off)

