

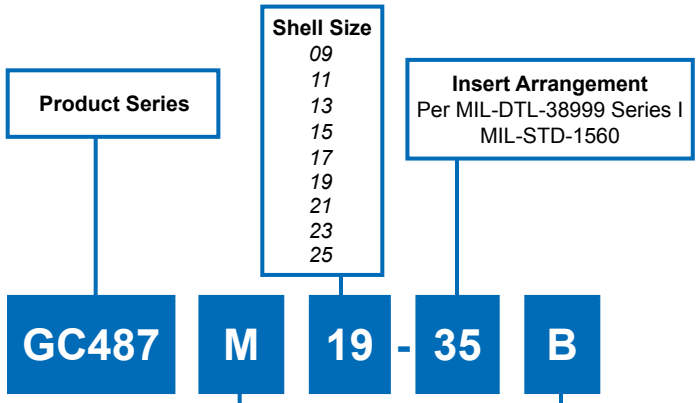

GC487 Shorting Bulkhead Feed-Thru MIL-DTL-38999 Series I Type



Connector Material and Finish
See Table II for Options

Alternate Key Position
A, B, C, D,
(N = Normal)

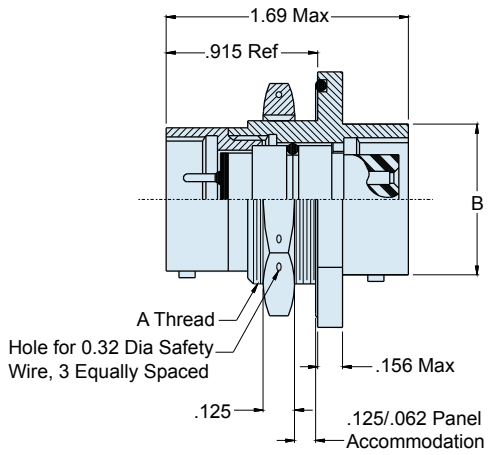

D

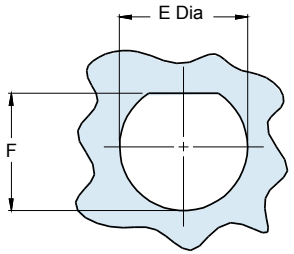
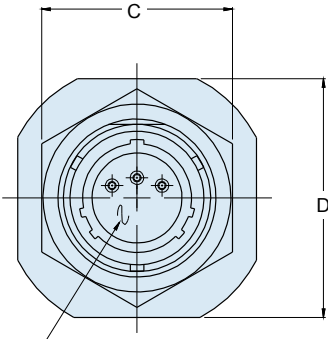

Recommended Panel Cut-Out

Insert Arrangement, per MIL-C-38999, Series I

TABLE II: FINISH	
SYM	FINISH
M	Electroless Nickel
MT	Ni-PTFE 1000 Hour Grey™ (Nickel-Fluorocarbon Polymer)
NF	Cadmium O.D. Over Electroless Nickel
N	Cadmium O.D. Over Nickel Plate

TABLE I: CONNECTOR DIMENSIONS						
SHELL SIZE	A THREAD CLASS 2A	B DIA MAX	C HEX	D FLATS	E DIA ±.005(0.1)	F +.000-.005 (0-0.1)
09	11/16-24 UNEF	.573(14.6)	.875(22.2)	1.062(27.0)	.703(17.9)	.669(17.0)
11	13/16-20 UNEF	.701(17.8)	1.000(25.4)	1.250(31.8)	.827(21.0)	.769(19.5)
13	1 -20 UNEF	.851(21.6)	1.188(30.2)	1.375(34.9)	1.015(25.8)	.955(24.3)
15	1 1/8-18 UNEF	.976(24.8)	1.312(33.3)	1.500(38.1)	1.140(29.0)	1.084(27.5)
17	1 1/4-18 UNEF	1.101(28.0)	1.438(36.5)	1.625(41.3)	1.265(32.1)	1.208(30.7)
19	1 3/8-18 UNEF	1.208(30.7)	1.562(39.7)	1.812(46.0)	1.390(35.3)	1.333(33.9)
21	1 1/2-18 UNEF	1.333(33.9)	1.688(42.9)	1.938(49.2)	1.515(38.5)	1.459(37.1)
23	1 5/8-18 UNEF	1.458(37.0)	1.812(46.0)	2.062(52.4)	1.640(41.7)	1.580(40.1)
25	1 3/4-18 UNS	1.583(40.2)	2.000(50.8)	2.188(55.6)	1.765(44.8)	1.709(43.4)

APPLICATION NOTES	
<ol style="list-style-type: none"> Assembly identified with manufacturer's name and part number, space permitting Material/finish: Shell assembly, jam nut, lock ring—al alloy/see Table II 	<p>Contacts—copper alloy/gold plate Bayonet pins—CRES/passivate O-rings, interfacial & peripheral seals—silicone/N.A. Insulators—high grade rigid dielectric/ N.A.</p> <ol style="list-style-type: none"> Metric Dimensions (mm) are indicated in parentheses